

PERÇAGE	3
FRAISAGE	95
GRAVAGE	221
TRONÇONNAGE	237
FILETAGE	277
ALÉSAGE	333
OUTILS DIAMANT, PCD & CBN	351
PIÈCES D'USURE	387
INFORMATIONS GÉNÉRALES	395

















PERÇAGE

BOHREN

DRILLING

FORATURA

FÚRÁS

	SÉLECTION DES FORETS	4
	FORETS À CENTRER ET À POINTER	10
	MÈCHES À CANON HÉLICOÏDALES Z = 1	17
	FORETS HÉLICOÏDAUX CYLINDRIQUES	18
	FORETS HÉLICOÏDAUX CORPS RENFORCÉ	29
	FORETS HÉLICOÏDAUX AUTO-CENTRANTS	51
	FORETS HÉLICOÏDAUX AUTO-CENTRANTS À TROUS DE LUBRIFICATION	55
	FORETS HÉLICOÏDAUX ACIERS TREMPÉS > 45 HRC	59
	FORETS HÉLICOÏDAUX Z = 3	61
	FORETS POUR MATIÈRES COMPOSITES / KEVLAR®	65
	FORETS ÉTAGÉS ET OUTILS SUR DEMANDE	67
	GÉOMÉTRIE, INFORMATIONS	71
	CONDITIONS DE COUPE	72

SÉLECTION DES FORETS

✓ = article de stock

		Z	Page	Lc	<input type="checkbox"/> CARBURE	<input type="checkbox"/> DICUT	<input type="checkbox"/> TITAIN		
FORETS À POINTER ET À CENTRER									
DIXI 1101 R Ø 0.80 - 4.00		2	10		✓				
DIXI 1106 R Ø 1.00 - 20.00		2	11		✓		✓		
DIXI 1106 L Ø 4.00 - 6.00		2	12		✓				
DIXI 1107 R Ø 1.00 - 20.00		2	12		✓				
DIXI 1108 R Ø 0.50 - 2.50		2	13	1 - 2 x Ø	✓		✓		
DIXI 1109 R Ø 0.50 - 2.50		2	15	1 - 2 x Ø	✓	✓			
DIXI 1110 R Ø 0.80 - 1.45		2	16	1 - 2 x Ø	✓		✓		
MÈCHES À CANON HÉLICOÏDALES Z = 1									
DIXI 1111 R Ø 0.10 - 2.00		1	17	4 - 9 x Ø	✓				
FORETS HÉLICOÏDAUX CYLINDRIQUES Z = 2									
DIXI 1126 R Ø 1.00 - 14.00		2	18	 7 - 12 x Ø	✓	✓			
DIXI 1130 R Ø 0.30 - 16.00		2	20	 2 - 16 x Ø	✓	✓			
DIXI 1130 L Ø 0.30 - 8.00		2	23	4 - 16 x Ø	✓	✓			
DIXI 1132 R Ø 0.40 - 2.00		2	26	4 - 15 x Ø	✓	✓			



○ bien ⊙ excellent

Acier + Pb	Acier faibl. allié	Aciers fort. allié	Acier inox aust.	Aciers Fontes 45-65 HRC	Fontes	Super alliages Ni / Co	Titane, alliages de titane	Alliage Cu Argent Or	Alliage Cu difficile	Alu	Graphite	Plastique
------------	--------------------	--------------------	------------------	-------------------------	--------	------------------------	----------------------------	----------------------	----------------------	-----	----------	-----------

⊙	○	○	○		⊙	○	○	⊙	○	⊙		⊙
⊙	⊙	○	⊙		⊙	○	⊙	⊙	⊙	⊙		⊙
⊙	⊙	○	⊙		⊙	○	⊙	⊙	⊙	⊙		⊙
⊙	⊙	○	⊙		⊙	○	⊙	⊙	⊙	⊙		⊙
⊙	⊙	○	⊙		⊙	○	⊙	⊙	⊙	⊙		⊙
⊙	⊙	○	⊙		⊙	○	⊙	⊙	⊙	⊙		⊙
⊙	⊙	○	⊙		⊙	○	⊙	⊙	⊙	⊙		⊙











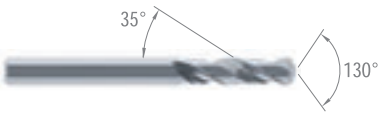

⊙								⊙	⊙			
---	--	--	--	--	--	--	--	---	---	--	--	--

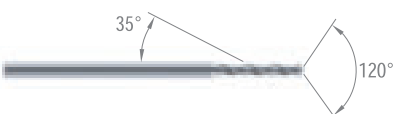
⊙	○	○	○		⊙	○	○	⊙	○	○	○	○
⊙	○	○			⊙		○	⊙	○	○	○	○
⊙	○	○			⊙		○	⊙	○	○	○	○
○	⊙	○	⊙		○	○	⊙	○	⊙	○	○	○

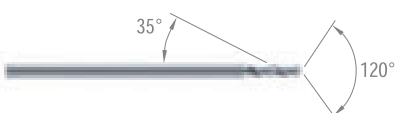
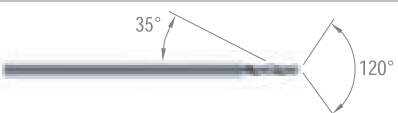
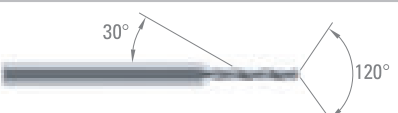

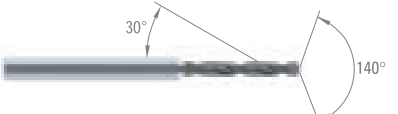
SÉLECTION DES FORETS

✓ = article de stock

FORETS HÉLICOÏDAUX CYLINDRIQUES Z = 2	Z	Page	Lc	<input type="checkbox"/> CARBURE	<input checked="" type="checkbox"/> DICUT	<input checked="" type="checkbox"/> TAIN	<input checked="" type="checkbox"/> DLC	<input checked="" type="checkbox"/> XIDUR	
DIXI 1133 R Ø 0.50 - 6.00 	2	27	4 - 18 x Ø	✓	✓				
FORETS HÉLICOÏDAUX CORPS RENFORCÉ Z = 2									
DIXI 1131 R Ø 0.05 - 2.45 	2	29	 4 - 9 x Ø	✓	✓		✓		
DIXI 1131 L Ø 0.10 - 2.45 	2	34	 4 - 9 x Ø	✓	✓				
DIXI 1134 R Ø 0.50 - 1.95 	2	38	 6 - 9 x Ø	✓	✓				
DIXI 1135 R Ø 0.20 - 2.49 	2	40	3 - 8 x Ø	✓	✓				
DIXI 1136 R Ø 0.20 - 1.99 	2	45	4 - 8 x Ø	✓	✓				
DIXI 1138 R Ø 0.05 - 2.80 	2	49	4 - 9 x Ø	✓		✓			
FORETS HÉLICOÏDAUX AUTO-CENTRANTS Z = 2									
DIXI 1149 R Ø 1.00 - 14.00 	2	51	 3 - 4 x Ø			✓			
DIXI 1147 R Ø 0.50 - 10.00 	2	53	6.5 x Ø			✓			
FORETS HÉLICOÏDAUX AUTO-CENTRANTS À TROUS DE LUBRIFICATION Z = 2									
DIXI 1145 R Ø 0.70 - 14.00 	2	55	 5 - 7 x Ø			✓			
DIXI 1146 R Ø 0.80 - 10.00 	2	57	10 x Ø			✓			
FORETS HÉLICOÏDAUX ACIERS TREMPÉS > 45 HRC									
DIXI 1280 R Ø 0.25 - 12.00 	2	59	3 - 7 x Ø					✓	



○ bien ⊙ excellent

Acier + Pb	Acier faibl. allié	Aciers fort. allié	Acier inox aust.	Aciers Fontes 45-65 HRC	Fontes	Super alliages Ni / Co	Titane, alliages de titane	Alliage Cu Argent Or	Alliage Cu difficile	Alu	Graphite	Plastique
------------	--------------------	--------------------	------------------	-------------------------	--------	------------------------	----------------------------	----------------------	----------------------	-----	----------	-----------

○	○	○	○		○		○	⊙	⊙	⊙		○
---	---	---	---	--	---	--	---	---	---	---	--	---

⊙	○	○	○		⊙	○	⊙	⊙	○	○	⊙	○
---	---	---	---	--	---	---	---	---	---	---	---	---

⊙	○	○	○		⊙	○	⊙	⊙	○	○	○	○
---	---	---	---	--	---	---	---	---	---	---	---	---

○	⊙	○	⊙		○	○	⊙	○	⊙	○		
---	---	---	---	--	---	---	---	---	---	---	--	--

○	⊙	○	⊙		○	○	⊙	○	⊙	○		
---	---	---	---	--	---	---	---	---	---	---	--	--

○	⊙	○	⊙		○	○	⊙	○	⊙	○		
---	---	---	---	--	---	---	---	---	---	---	--	--

○	⊙	○	⊙		○	○	⊙	○	⊙	○		
---	---	---	---	--	---	---	---	---	---	---	--	--

○	○	⊙	⊙		⊙	○	⊙		○	○		
---	---	---	---	--	---	---	---	--	---	---	--	--

⊙	⊙	⊙	○		○	⊙	○			○		
---	---	---	---	--	---	---	---	--	--	---	--	--

○	○	⊙	⊙		⊙	○	⊙		○	○		
---	---	---	---	--	---	---	---	--	---	---	--	--

⊙	⊙	⊙	○		○	⊙	○			○		
---	---	---	---	--	---	---	---	--	--	---	--	--

		○		⊙		○						
--	--	---	--	---	--	---	--	--	--	--	--	--



SÉLECTION DES FORETS

✓ = article de stock

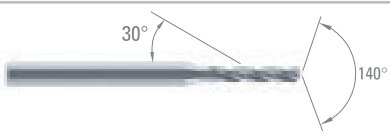
FORETS HÉLICOÏDAUX Z = 3	Z	Page	Lc	<input type="checkbox"/> CARBURE					
DIXI 1151 R Ø 1.00 - 14.00 	3	61	3 - 8 x Ø	✓					
DIXI 1152 R Ø 0.15 - 2.90 	3	63	6 - 10 x Ø	✓					

FORETS POUR MATIÈRES COMPOSITES / KEVLAR®

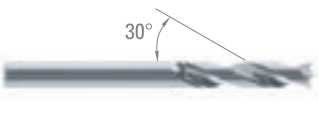
DIXI 1290 R Ø 2.50 - 12.70 	2	65	3 - 7 x Ø	✓					
---	---	----	-----------	---	--	--	--	--	--

OUTILS SUR DEMANDE

FORETS PLATS

DIXI 1112 R+L Ø 0.08 - 5.99 	2	66							
--	---	----	--	--	--	--	--	--	--





MÈCHES À CANON DEMI-LUNE

DIXI 1114 R+L Ø 0.08 - 5.99 	1	66							
--	---	----	--	--	--	--	--	--	--

FORETS DENTURE DROITE

DIXI 1118 R+L Ø 0.08 - 5.99 	2	66							
--	---	----	--	--	--	--	--	--	--

FORETS ÉTAGÉS

DIXI 1501 R+L 		67							
DIXI 1502 R+L 		68							
DIXI 1503 R+L 		69							
DIXI 1504 R+L 		70							



○ bien ⊙ excellent

Acier + Pb	Acier faibl. allié	Aciers fort. allié	Acier inox aust.	Aciers Fontes 45-65 HRC	Fontes	Super alliages Ni / Co	Titane, alliages de titane	Alliage Cu Argent Or	Alliage Cu difficile	Alu	Graphite	Plastique
------------	--------------------	--------------------	------------------	-------------------------	--------	------------------------	----------------------------	----------------------	----------------------	-----	----------	-----------

○	○				⊙		⊙	⊙		○		
○	○				⊙		⊙	⊙		○		

Kevlar®

												⊙
--	--	--	--	--	--	--	--	--	--	--	--	---

○					○			⊙	○	○		○
---	--	--	--	--	---	--	--	---	---	---	--	---

⊙								⊙	⊙			○
---	--	--	--	--	--	--	--	---	---	--	--	---

○					○			⊙	○	○		○
---	--	--	--	--	---	--	--	---	---	---	--	---

⊙	○	○	○		○	○	○	⊙	○	⊙		○
---	---	---	---	--	---	---	---	---	---	---	--	---

⊙	○	○	○		○	○	○	⊙	○	⊙		○
---	---	---	---	--	---	---	---	---	---	---	--	---

⊙	○	○	○		○	○	○	⊙	○	⊙		○
---	---	---	---	--	---	---	---	---	---	---	--	---

⊙	○	○	○		○	○	○	⊙	○	⊙		○
---	---	---	---	--	---	---	---	---	---	---	--	---



DIXI 1101 R 60°

FORETS À CENTRER

Z = 2



P. 72

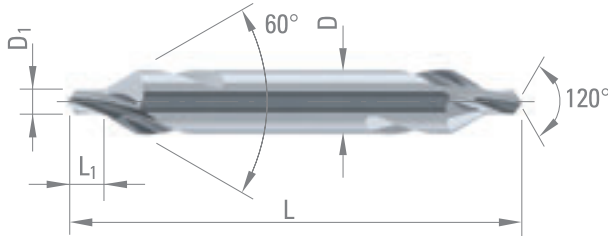

Acier + Pb	Acier faibl. allié	Acier fort. allié	Acier inox aust.	Fontes
Super alliages Ni / Co	Titane, alliage de titane	Alliage Cu Argent Or	Alliage Cu difficile	Alu
Plastique				

D ₁	L ₁	D _{h5}	L	CARBURE
0.80 ^{+0.14} ₀	1.30 ^{±0.1}	3.15	31.50 ^{±2}	37253
1.00 ^{+0.14} ₀	1.60 ^{±0.2}	3.15	31.50 ^{±2}	37254
1.25 ^{+0.14} ₀	1.90 ^{±0.2}	3.15	31.50 ^{±2}	37255
1.60 ^{+0.14} ₀	2.40 ^{±0.2}	4.00	35.50 ^{±2}	37256
2.00 ^{+0.14} ₀	2.90 ^{±0.2}	5.00	40.00 ^{±2}	29156
2.50 ^{+0.14} ₀	3.60 ^{±0.2}	6.30	45.00 ^{±2}	37257
* 3.15 ^{+0.18} ₀	4.40 ^{±0.3}	8.00	50.00 ^{±2}	24756
* 4.00 ^{+0.18} ₀	5.60 ^{±0.4}	10.00	56.00 ^{±3}	32950

* = avec amincissement d'âme

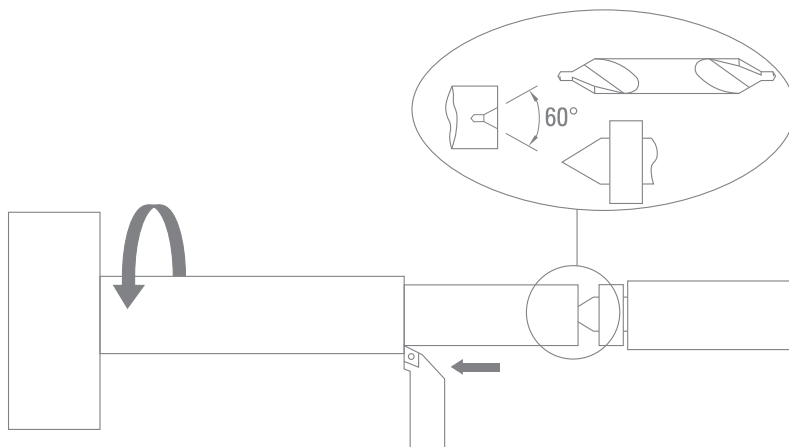

DIXI 1106 R 90°

FORETS À POINTER NC

Z = 2



P. 72

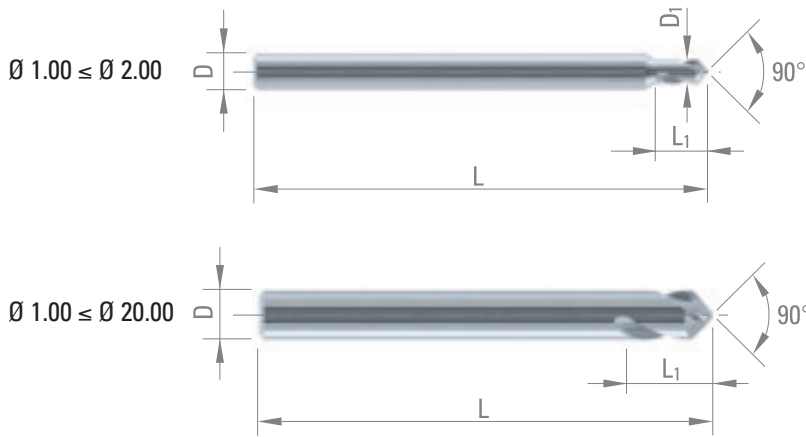

Acier + Pb	Acier faibl. allié	Acier fort. allié	Acier inox aust.	Fontes
Super alliages Ni / Co	Titane, alliage de titane	Alliage Cu Argent Or	Alliage Cu difficile	Alu
Plastique				

D _{1h6}	L ₁	D _{h5}	L	CARBURE	TiAIN
1.00	3	3	38	956799	957230
1.50	5	3	38	956800	957231
2.00	5	3	38	956801	957232

D _{h5}	L ₁	L	CARBURE	TiAIN
1.00	3	32	953781	953780
1.50	5	32	953778	953779
2.00	5	32	47101	62892
3.00	9	38	43231	34090
4.00	10	50	36911	61280
5.00	13	50	47716	63736
* 6.00	13	57	42788	63757
* 8.00	27	63	42789	63758
* 10.00	30	72	43233	61561
* 12.00	35	83	43064	41463
* 16.00	46	92	43234	63759
* 20.00	52	104	43235	63760

* = affûtage logarithmique

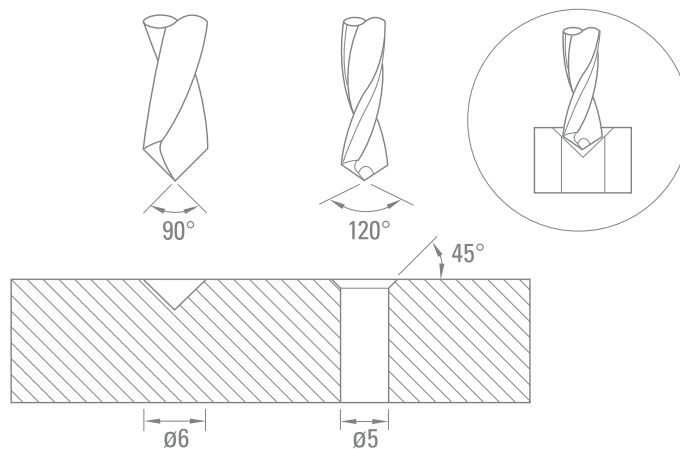

DIXI 1106 L 90°

FORETS À POINTER NC
À GAUCHE

Z = 2



P. 72

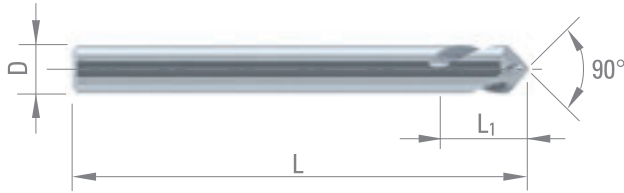

D _{h5}	L ₁	L	CARBURE
4.00	10	50	47714
5.00	13	50	47715
6.00	13	57	48813

Acier + Pb	Acier faibl. allié	Acier fort. allié	Acier inox aust.	Fontes
Super alliages Ni / Co	Titane, alliage de titane	Alliage Cu Argent Or	Alliage Cu difficile	Alu
Plastique				

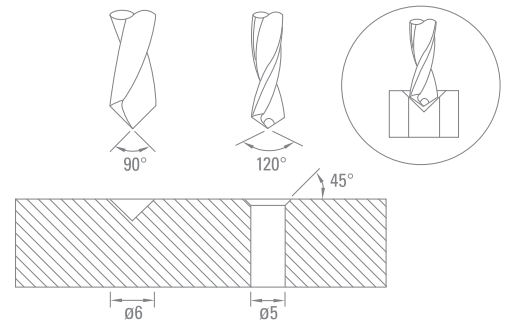

DIXI 1107 R 120°

FORETS À POINTER NC

Z = 2



P. 72

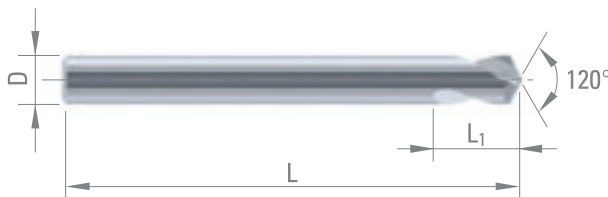

D _{h5}	L ₁	L	CARBURE
1.00	3	38	985118
2.00	5	38	985120
3.00	9	38	43236
4.00	10	50	36914
6.00	13	57	43238
* 8.00	27	63	43239
* 10.00	30	72	43240
* 12.00	35	83	43241
* 16.00	46	92	43242
* 20.00	52	104	43243

Acier + Pb	Acier faibl. allié	Acier fort. allié	Acier inox aust.	Fontes
Super alliages Ni / Co	Titane, alliage de titane	Alliage Cu Argent Or	Alliage Cu difficile	Alu
Plastique				

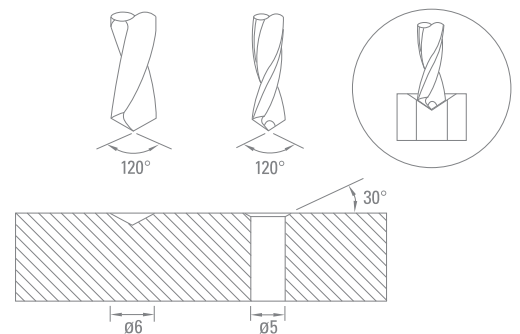

* = affûtage logarithmique

DIXI 1108 R 90°

FORETS À POINTER
CORPS RENFORCÉ

Z = 2



P. 72

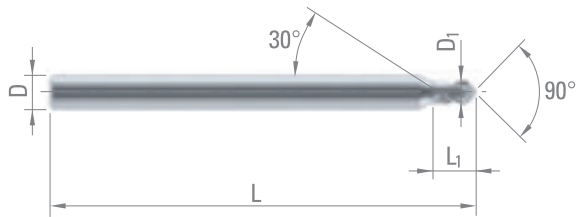

Acier + Pb	Acier faibl. allié	Acier fort. allié	Acier inox aust.	Fontes
Super alliages Ni / Co	Titane, alliage de titane	Alliage Cu Argent Or	Alliage Cu difficile	Alu
Plastique				

D _{1 h6}	L ₁	D _{h5}	L	CARBURE	TiAIN
0.50	1.0	3	38	983702	
0.60	1.0	3	38	964801	
0.65	1.0	3	38	964800	
0.70	1.0	3	38	964799	
0.75	1.0	3	38	964798	
0.80	1.5	3	38	956678	956679
0.82	1.5	3	38	956681	956682
0.85	1.5	3	38	956684	956685
0.87	1.5	3	38	956687	956689
0.90	1.5	3	38	956691	956693
0.92	1.5	3	38	956695	956696
0.95	1.5	3	38	956697	956703
0.97	1.5	3	38	956704	956706
1.00	1.5	3	38	956708	956707
1.02	2.0	3	38	956709	956710
1.05	2.0	3	38	956711	956712
1.07	2.0	3	38	956713	956714
1.10	2.0	3	38	956715	956716
1.12	2.0	3	38	956717	956718
1.15	2.0	3	38	956719	956720
1.17	2.0	3	38	956721	956722
1.20	2.0	3	38	956723	956724
1.22	2.0	3	38	956725	956726
1.25	2.0	3	38	956727	956728
1.27	2.0	3	38	956729	956730
1.30	2.0	3	38	956731	956732
1.32	2.0	3	38	956733	956734
1.35	2.0	3	38	956735	956736
1.37	2.0	3	38	956737	956738
1.40	2.0	3	38	956739	956740
1.42	2.0	3	38	956741	956742
1.45	2.0	3	38	956743	956744
1.47	2.0	3	38	956745	956746
1.50	2.0	3	38	956747	956748
1.52	3.0	3	38	956749	956750
1.55	3.0	3	38	956751	956752
1.57	3.0	3	38	956753	956754
1.60	3.0	3	38	956755	956756
1.62	3.0	3	38	956757	956758
1.65	3.0	3	38	956759	956760
1.67	3.0	3	38	956761	956762



DIXI 1108 R 90°

$D_{1\ h6}$	L_1	D_{h5}	L	CARBURE	TiAIN
1.70	3.0	3	38	956763	956764
1.72	3.0	3	38	956765	956766
1.75	3.0	3	38	956767	956768
1.77	3.0	3	38	956769	956770
1.80	3.0	3	38	956771	956772
1.82	3.0	3	38	956773	956774
1.85	3.0	3	38	956775	956776
1.87	3.0	3	38	956777	956778
1.90	3.0	3	38	956779	956780
1.92	3.0	3	38	956781	956782
1.95	3.0	3	38	956783	956784
1.97	3.0	3	38	956785	956786
2.00	3.0	3	38	956803	956804
2.10	3.0	3	38	956812	956813
2.20	3.0	3	38	956820	956821
2.30	3.0	3	38	956828	956830
2.40	3.0	3	38	956837	956838
2.50	3.0	3	38	956845	956846



P. 72

Acier + Pb	Acier faibl. allié	Acier fort. allié	Acier inox aust.	Fontes
Super alliages Ni / Co	Titane, alliage de titane	Alliage Cu Argent Or	Alliage Cu difficile	Alu
Plastique				

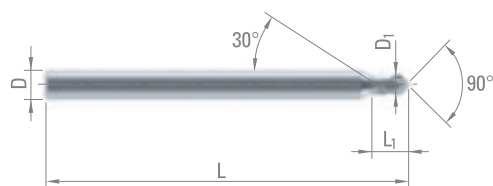

DIXI 1109 R 120°

FORETS À POINTER CORPS RENFORCÉ

Z = 2



P. 72

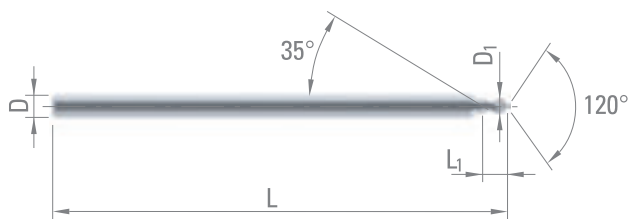

Acier + Pb	Acier faibl. allié	Acier fort. allié	Acier inox aust.	Fontes
Super alliages Ni / Co	Titane, alliage de titane	Alliage Cu Argent Or	Alliage Cu difficile	Alu
Plastique				

D _{10/-0.004}	L ₁	D _{h5}	L	CARBURE	DICUT
0.50	1.0	1.5	30	62674	67354
0.55	1.0	1.5	30	62675	67355
0.60	1.2	1.5	30	62676	67356
0.65	1.2	1.5	30	62677	67357
0.70	1.5	1.5	30	62678	67358
0.75	1.5	1.5	30	62679	67359
0.80	2.0	1.5	30	52126	60989
0.85	2.0	1.5	30	52127	67360
0.90	2.0	1.5	30	52128	60990
0.95	2.0	1.5	30	52129	67361
1.00	2.0	1.5	30	52130	60991
1.05	2.0	1.5	30	52131	67362
1.10	2.0	1.5	30	52132	60992
1.15	2.4	1.5	30	52133	62487
1.20	2.4	1.5	30	52134	60993
1.25	2.4	1.5	30	52135	67363
1.30	2.4	1.5	30	52136	60994
1.35	2.4	1.5	30	52137	67364
1.40	2.4	1.5	30	52138	63485
1.45	2.4	1.5	30	52139	67365
1.50	3.0	2.0	32	981825	981839
1.55	3.0	2.0	32	981826	981840
1.60	3.0	2.0	32	981827	981841
1.65	3.0	2.0	32	981828	981842
1.70	3.0	2.0	32	981829	981843
1.75	3.5	2.0	32	981830	981844
1.80	3.5	2.0	32	981831	981845
1.85	3.5	2.0	32	981832	981847
1.90	3.5	2.0	32	981833	981848
1.95	3.5	2.0	32	981834	981849
2.00	4.0	2.5	32	981317	981325
2.10	4.0	2.5	32	981835	981850
2.20	4.0	2.5	32	981836	981852
2.30	4.0	2.5	32	981837	981853
2.40	4.0	2.5	32	981838	981854
2.50	4.0	2.5	32	981320	981327

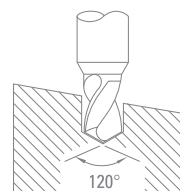
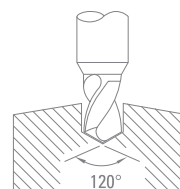
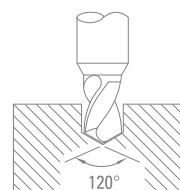

DIXI 1110 R 120°

FORETS À POINTER ET CHANFREINER

Z = 2



P. 72

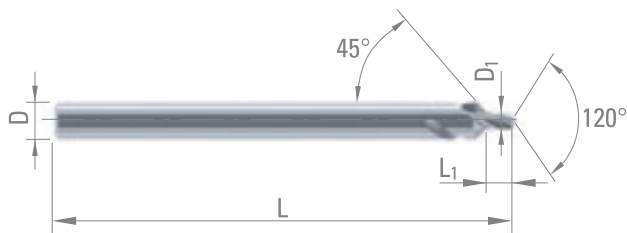

Acier + Pb	Acier faibl. allié	Acier fort. allié	Acier inox aust.	Fontes
Super alliages Ni / Co	Titane, alliage de titane	Alliage Cu Argent Or	Alliage Cu difficile	Alu
Plastique				

$D_{10/-0.004}$	L_1	D_{h5}	L	CARBURE	TiAIN
0.80	2.0	3	38	60268	64055
0.85	2.0	3	38	60269	67239
0.90	2.0	3	38	60270	64000
0.95	2.0	3	38	60271	67240
1.00	2.0	3	38	60272	64056
1.05	2.0	3	38	60273	67241
1.10	2.0	3	38	60274	63523
1.15	2.4	3	38	60275	67242
1.20	2.4	3	38	60276	64001
1.25	2.4	3	38	60277	67243
1.30	2.4	3	38	60278	67244
1.35	2.4	3	38	60279	67245
1.40	2.4	3	38	60280	64002
1.45	2.4	3	38	60281	67246



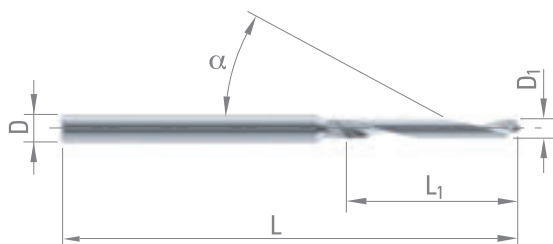

Acier
+ Pb

Alliage Cu
Argent
Or

Alliage
Cu
difficile

$D_{10/-0.004}$	L_1	D_{h5}	L	CARBURE
0.10	0.7	1.0	30	955371
0.15	1.0	1.0	30	955374
0.20	1.0	1.0	30	955375
0.25	1.0	1.0	30	955377
0.30	1.5	1.0	30	955378
0.35	1.5	1.0	30	955379
0.40	2.0	1.0	30	955380
0.45	3.6	1.0	30	955381
0.50	4.0	1.0	30	955382
0.55	4.5	1.0	30	955383
0.60	4.5	1.0	30	955384
0.65	5.0	1.0	30	955385
0.70	5.6	1.0	30	955386
0.75	5.6	1.0	30	955387
0.80	6.3	1.5	30	955388
0.85	6.3	1.5	30	955389
0.90	7.1	1.5	30	955390
0.95	7.1	1.5	30	955391
1.00	9.0	1.5	30	955392
1.05	9.0	1.5	30	955393
1.10	9.0	1.5	30	955394
1.15	9.0	1.5	30	955395
1.20	10.0	1.5	30	955396
1.30	10.0	1.5	30	965839
1.40	11.2	1.5	30	965840
1.45	11.2	1.5	30	965841
1.50	12.0	2.0	38	961881
1.60	12.0	2.0	38	965842
1.65	12.0	2.0	38	965843
1.70	12.0	2.0	38	961882
1.75	12.0	2.0	38	965844
1.80	12.0	2.0	38	961883
2.00	12.0	2.5	43	959038

Autres diamètres jusqu'à Ø 5.99 sur demande



DIXI 1126 R

FORETS HÉLICOÏDAUX

Z = 2



P. 71



P. 76

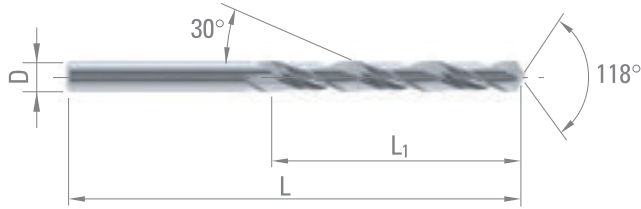

Acier + Pb	Acier faibl. allié	Acier fort. allié	Acier inox aust.	Fontes
Super alliages Ni / Co	Titane, alliage de titane	Alliage Cu Argent Or	Alliage Cu difficile	Alu
Graphite	Plastique			

D _{h5}	L ₁	L	CARBURE	DICUT
1.00	12	34	40244	53697
1.10	14	36	40656	53698
1.20	16	38	40657	53699
1.30	16	38	40658	53700
1.40	18	40	40659	53701
1.50	18	40	40077	53702
1.60	20	43	40703	53703
1.70	20	43	38677	53704
1.80	22	46	41510	53705
1.90	22	46	41370	53706
2.00	24	49	41593	53707
2.10	24	49	40707	53708
2.20	27	53	40125	53709
2.30	27	53	43515	53710
2.40	30	57	45074	53711
2.50	30	57	40978	53712
2.60	30	57	40607	53713
2.70	33	61	41318	53714
2.80	33	61	41024	54284
2.90	33	61	40608	53715
3.00	33	61	40059	53716
3.10	36	65	40173	53717
3.20	36	65	41511	53718
3.30	36	65	40575	53736
3.40	39	70	41247	53737
3.50	39	70	41451	53738
3.60	39	70	40078	53739
3.70	39	70	40174	53740
3.80	43	75	40060	53741
3.90	43	75	43676	53742
4.00	43	75	43497	53743
4.10	43	75	41218	53744
4.20	43	75	41295	53745
4.30	47	80	41452	53746
4.40	47	80	42866	53747
4.50	47	80	40263	53748
4.60	47	80	41991	53749
4.70	47	80	34710	53750
4.80	52	86	40126	53751
4.90	52	86	42661	53752



DIXI 1126 R

D _{h5}	L ₁	L	CARBURE	DICUT
5.00	52	86	40061	53753
5.10	52	86	42022	53754
5.20	52	86	40062	53755
5.30	52	86	40063	53756
5.40	57	93	40064	53757
5.50	57	93	40065	53758
5.60	57	93	41992	53759
5.70	57	93	43357	53760
5.80	57	93	40864	53761
5.90	57	93	40258	53762
6.00	57	93	39996	53763
6.10	63	101	40704	54264
6.20	63	101	40066	54267
6.30	63	101	40067	54283
6.40	63	101	40068	54287
6.50	63	101	40069	54290
6.60	63	101	40070	54293
6.70	63	101	40071	54304
6.80	69	109	40943	54306
6.90	69	109	41512	54309
7.00	69	109	40072	54312
7.50	69	109	40912	54315
7.70	75	117	53196	54318
7.80	75	117	45792	54321
8.00	75	117	40073	54324
8.50	75	117	40074	54811
9.00	81	125	40075	54778
9.50	81	125	41641	54781
10.00	87	133	40812	54784
10.20	87	133	40944	54787
10.50	87	133	34732	54790
11.00	94	142	40127	54793
11.50	94	142	40865	54795
12.00	101	151	41513	54798
12.50	101	151	41642	54801
13.00	101	151	40660	54804
13.50	108	160	40076	54807
14.00	108	160	40771	54810



P. 71



P. 76



Acier + Pb	Acier faibl. allié	Acier fort. allié	Acier inox aust.	Fontes
Super alliages Ni / Co	Titane, alliage de titane	Alliage Cu Argent Or	Alliage Cu difficile	Alu
Graphite	Plastique			

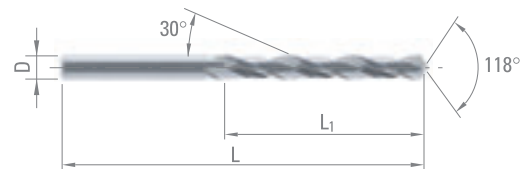

DIXI 1130 R

FORETS HÉLICOÏDAUX

Z = 2



P. 71



P. 78



DIN
6539

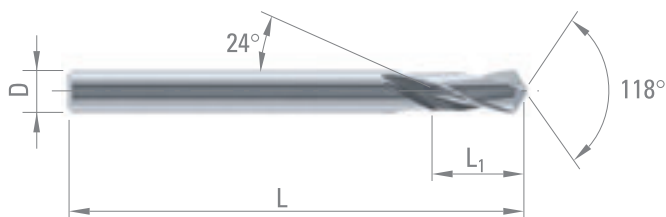

Acier + Pb	Acier faibl. allié	Acier fort. allié	Fontes	Titane, alliage de titane
Alliage Cu Argent Or	Alliage Cu difficile	Alu	Graphite	Plastique

D _{h5}	L ₁	L	CARBURE	DICUT
0.30	5	30	24828	953165
0.35	5	30	37861	953167
0.40	6	30	244	953169
0.45	6	30	245	953171
0.50	6	30	246	54480
0.55	6	30	247	54481
0.60	6	30	248	54482
0.65	6	30	249	54483
0.70	6	30	250	54484
0.75	6	30	251	54485
0.80	7	30	252	54487
0.85	7	30	253	54486
0.90	7	30	254	54528
0.95	7	30	255	54488
1.00	7	30	256	54490
1.05	8	30	257	54491
1.10	8	30	258	54492
1.15	8	30	259	54493
1.20	8	30	260	54494
1.25	8	30	261	54495
1.30	8	30	262	54496
1.35	8	30	263	54497
1.40	8	30	264	54498
1.45	8	30	265	54499
1.50	8	30	266	54500
1.55	9	38	267	54501
1.60	9	38	268	54502
1.65	9	38	269	54503
1.70	9	38	270	54504
1.75	9	38	271	54505
1.80	9	38	272	54506
1.85	9	38	32277	54507
1.90	9	38	274	54509
1.95	9	38	275	54508
2.00	9	38	276	54510
2.05	9	38	39575	54511
2.10	9	38	39577	54512
2.15	10	40	33192	54513
2.20	10	40	39655	54514



DIXI 1130 R

D _{h5}	L ₁	L	CARBURE	DICUT
2.25	10	40	4562	54516
2.30	10	40	43350	54529
2.35	10	40	1756	54530
2.40	11	43	42869	54531
2.45	11	43	4563	54532
2.50	11	43	43351	54533
2.55	11	43	41514	54534
2.60	11	43	41874	54535
2.65	11	43	4564	54536
2.70	12	46	42139	54539
2.75	12	46	4565	54537
2.80	12	46	42339	54538
2.85	12	46	42522	54540
2.90	12	46	41911	54541
2.95	12	46	41501	54542
3.00	12	46	41840	54543
3.05	14	49	4607	54544
3.10	14	49	41456	54545
3.15	14	49	1757	54546
3.20	14	49	42023	54547
3.25	14	49	3356	54548
3.30	14	49	290	54549
3.35	14	49	4567	54550
3.40	15	52	42200	54551
3.45	15	52	4020	54552
3.50	15	52	41534	54553
3.55	15	52	4568	54554
3.60	15	52	41535	54556
3.65	15	52	42523	54557
3.70	15	52	43037	54558
3.75	15	52	4570	54560
3.80	17	55	4610	54562
3.85	17	55	4571	54563
3.90	17	55	4142	54565
3.95	17	55	42870	54567
4.00	17	55	42093	54568
4.05	17	55	42871	54569
4.10	17	55	42652	54570
4.15	17	55	15177	54571
4.20	17	55	42340	54572
4.25	17	55	39938	54573
4.30	18	58	301	54574
4.35	18	58	39939	54575
4.40	18	58	29689	54576
4.45	18	58	4616	54577
4.50	18	58	303	54578
4.55	18	58	40790	54579
4.60	18	58	39013	54580
4.65	18	58	19790	54581
4.70	18	58	42170	54582
4.75	18	58	40791	54583
4.80	20	62	29756	54584
4.85	20	62	42524	54585
4.90	20	62	41914	54586
4.95	20	62	39997	54587



P. 71



P. 78



Acier + Pb	Acier faibl. allié	Acier fort. allié	Fontes	Titane, alliage de titane
Alliage Cu Argent Or	Alliage Cu difficile	Alu	Graphite	Plastique

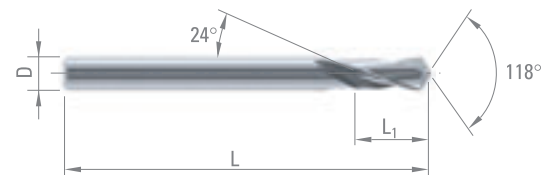

DIXI 1130 R

D _{h5}	L ₁	L	CARBURE	DICUT
5.00	20	62	29758	54588
5.10	20	62	29759	54589
5.20	20	62	29760	54590
5.30	20	62	29761	54593
5.40	21	66	29693	54594
5.50	21	66	29694	54595
5.60	21	66	41594	54596
5.70	21	66	45724	54597
5.80	21	66	316	54599
5.90	21	66	28594	54600
6.00	21	66	42173	54601
6.10	23	70	29762	54602
6.20	23	70	41457	54618
6.30	23	70	29764	54619
6.40	23	70	42171	54620
6.50	23	70	42220	54621
6.60	23	70	41515	54622
6.70	23	70	41680	54623
6.80	25	74	326	54624
6.90	25	74	327	54625
7.00	25	74	328	54626
7.10	25	74	8646	54627
7.20	25	74	50671	54628
7.30	25	74	53054	54629
7.40	25	74	53055	54630
7.50	25	74	5389	54631
7.60	27	79	53056	54632
7.70	27	79	22351	54633
7.80	27	79	50331	54634
7.90	27	79	53057	54635
8.00	27	79	42821	54636
8.10	27	79	53058	54639
8.20	27	79	25291	54640
8.30	27	79	53479	54641
8.40	27	79	53059	54642
8.50	27	79	42653	54643
8.80	29	84	57852	59399
9.00	29	84	35325	54644
9.20	29	84	57851	59401
9.50	29	84	39660	54645
9.80	31	89	57853	963531
10.00	31	89	7958	54646
10.20	31	89	34340	54647
10.50	31	89	30130	54648
11.00	33	95	28591	54649
11.50	33	95	41092	54650
12.00	35	102	14939	54651
12.50	35	102	25347	54652
13.00	35	102	21462	54653
13.50	37	107	45725	54654
14.00	37	107	23729	54655
16.00	38	115	48489	54656



P. 71



P. 78



Acier + Pb	Acier faibl. allié	Acier fort. allié	Fontes	Titane, alliage de titane
Alliage Cu Argent Or	Alliage Cu difficile	Alu	Graphite	Plastique

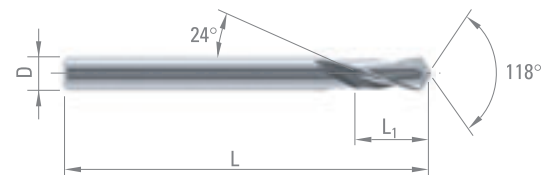

DIXI 1130 L

FORETS HÉLICOÏDAUX À GAUCHE

Z = 2



P. 71



P. 78

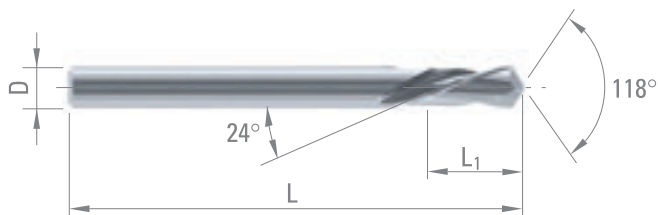

Acier + Pb	Acier faibl. allié	Acier fort. allié	Fontes	Titane, alliage de titane
Alliage Cu Argent Or	Alliage Cu difficile	Alu	Graphite	Plastique

D _{h5}	L ₁	L	CARBURE	DICUT
0.30	5	30	37906	953748
0.35	5	30	37907	953752
0.40	6	30	330	953754
0.45	6	30	331	953758
0.50	6	30	332	54659
0.55	6	30	333	54660
0.60	6	30	334	54661
0.65	6	30	335	54662
0.70	6	30	336	54663
0.75	6	30	37908	54664
0.80	8	30	338	54665
0.85	8	30	339	54666
0.90	8	30	340	54667
0.95	8	30	341	54668
1.00	8	30	29560	54669
1.05	10	30	343	54670
1.10	10	30	344	54671
1.15	10	30	345	54672
1.20	10	30	346	54673
1.25	10	30	347	54674
1.30	10	30	348	54675
1.35	10	30	349	54676
1.40	10	30	350	54677
1.45	10	30	351	54678
1.50	10	30	352	54679
1.55	16	38	38634	54680
1.60	16	38	38826	54681
1.65	16	38	39127	54682
1.70	16	38	39126	54683
1.75	16	38	38827	54684
1.80	16	38	395	54685
1.85	16	38	38921	54686
1.90	16	38	30637	54687
1.95	16	38	38997	54688



DIXI 1130 L

D _{h5}	L ₁	L	CARBURE	DICUT
2.00	16	38	35181	54689
2.05	16	38	27526	54690
2.10	16	38	39657	54691
2.15	16	40	39041	54692
2.20	16	40	38965	54693
2.25	16	40	40245	54694
2.30	16	40	38769	54695
2.35	16	40	26575	54696
2.40	16	43	23429	54698
2.45	16	43	45720	54699
2.50	16	43	43245	54700
2.55	16	43	41034	54701
2.60	16	43	39043	54702
2.65	16	43	4026	54703
2.70	16	46	40247	54704
2.75	16	46	43036	54705
2.80	16	46	370	54706
2.85	16	46	40266	54707
2.90	16	46	40793	54708
2.95	16	46	40511	54709
3.00	16	46	42787	54710
3.05	18	49	40079	54711
3.10	18	49	40661	54712
3.15	18	49	40794	54713
3.20	18	49	40267	54714
3.25	18	49	40080	54715
3.30	18	49	375	54716
3.35	18	49	40296	54717
3.40	20	50	376	54718
3.45	20	50	37957	54719
3.50	20	50	377	54720
3.55	20	50	41596	54721
3.60	20	50	40662	54722
3.65	20	50	40797	54723
3.70	20	50	379	54724
3.75	20	50	38922	54725
3.80	22	50	40172	54726
3.85	22	50	37960	54727
3.90	22	50	38923	54728
3.95	22	50	37962	54729
4.00	22	50	382	54730
4.05	22	50	40801	54731
4.10	22	50	383	54732
4.15	22	50	40576	54733
4.20	22	50	384	54734
4.25	22	50	39658	54735
4.30	24	50	385	54736
4.35	24	50	37966	54737
4.40	24	50	37967	54738
4.45	24	50	27518	54739



P. 71



P. 78

Acier + Pb	Acier faibl. allié	Acier fort. allié	Fontes	Titane, alliage de titane
Alliage Cu Argent Or	Alliage Cu difficile	Alu	Graphite	Plastique

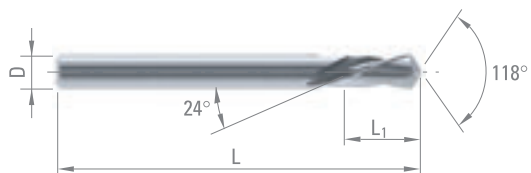

DIXI 1130 L

D _{h5}	L ₁	L	CARBURE	DICUT
4.50	24	50	387	54740
4.55	24	50	37968	54741
4.60	24	50	388	54742
4.65	24	50	37969	54743
4.70	24	50	39936	54744
4.75	24	50	37970	54745
4.80	25	50	390	54746
4.85	25	50	37971	54747
4.90	25	50	391	54748
4.95	25	50	37972	54749
5.00	25	50	392	54750
5.10	25	50	393	54751
5.20	25	50	4141	54752
5.30	25	50	25304	54753
5.40	25	50	37977	54754
5.50	25	50	27042	54755
5.60	25	50	27041	54756
5.70	25	50	37981	54757
5.80	25	50	26676	54758
5.90	25	50	6489	54759
6.00	28	66	43390	54760
6.10	31	70	43915	54761
6.20	31	70	43720	54762
6.30	31	70	43765	54763
6.40	31	70	45723	54764
6.50	31	70	37994	54765
6.60	31	70	37996	54766
6.70	31	70	45721	54767
6.80	34	74	43847	953776
6.90	34	74	45722	54769
7.00	34	74	43721	54770
7.50	34	74	38021	54771
8.00	37	79	26530	54772



P. 71



P. 78

Acier + Pb	Acier faibl. allié	Acier fort. allié	Fontes	Titane, alliage de titane
Alliage Cu Argent Or	Alliage Cu difficile	Alu	Graphite	Plastique

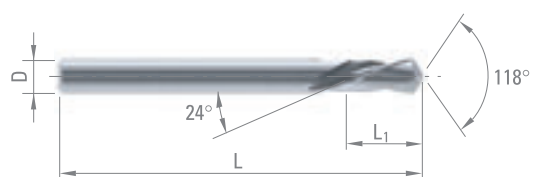

DIXI 1132 R

FORETS HÉLICOÏDAUX

Z = 2



P. 71



P. 82

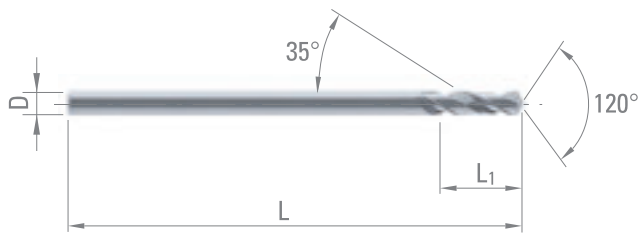

Acier + Pb	Acier faibl. allié	Acier fort. allié	Acier inox aust.	Fontes
Super alliages Ni / Co	Titane, alliage de titane	Alliage Cu Argent Or	Alliage Cu difficile	Alu
Graphite	Plastique			

D _{h5}	L ₁	L	CARBURE	DICUT
0.40	6	30	197	953186
0.45	6	30	198	58925
0.50	6	30	199	53585
0.55	6	30	200	53586
0.60	6	30	201	53582
0.65	6	30	202	53588
0.70	6	30	203	53589
0.75	6	30	204	53587
0.80	7	30	205	53590
0.85	7	30	206	53591
0.90	7	30	207	53592
0.95	7	30	208	53593
1.00	7	30	40275	53583
1.05	8	30	210	53594
1.10	8	30	41502	53595
1.15	8	30	212	53596
1.20	8	30	41150	53597
1.25	8	30	41319	53598
1.30	8	30	215	53599
1.35	8	30	41320	53600
1.40	8	30	217	53584
1.45	8	30	218	53601
1.50	8	30	219	53602
1.55	9	38	220	53604
1.60	9	38	221	53605
1.65	9	38	5418	53606
1.70	9	38	222	53607
1.75	9	38	42537	53608
1.80	9	38	223	53609
1.85	9	38	42538	53610
1.90	9	38	224	53611
1.95	9	38	42539	53612
2.00	9	38	225	53613



DIXI 1133 R

FORETS HÉLICOÏDAUX

Z = 2



P. 71



P. 84

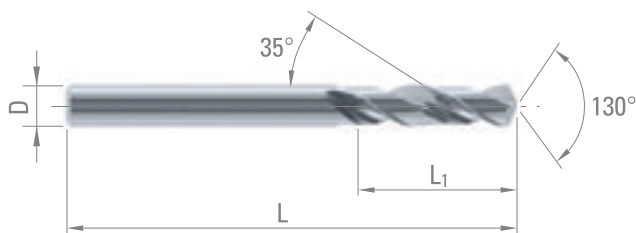

Acier + Pb	Acier faibl. allié	Acier fort. allié	Acier inox aust.	Fontes
Titane, alliage de titane	Alliage Cu Argent Or	Alliage Cu difficile	Alu	Plastique

D _{h5}	L ₁	L	CARBURE	DICUT
0.50	9	38	91	57557
0.55	9	38	92	57558
0.60	13	38	93	57559
0.65	13	38	94	57560
0.70	13	38	95	55471
0.75	13	38	96	55473
0.80	13	38	97	55475
0.85	13	38	98	55482
0.90	16	38	99	55599
0.95	16	38	100	55601
1.00	16	38	101	55603
1.05	16	38	102	55605
1.10	16	38	103	55607
1.15	16	38	104	55609
1.20	16	38	105	55611
1.25	16	38	106	55613
1.30	16	38	107	55615
1.35	16	38	108	55617
1.40	16	38	109	55619
1.45	16	38	110	55621
1.50	16	38	111	55623
1.55	16	38	2972	55625
1.60	16	38	112	55627
1.65	16	38	3360	55629
1.70	16	38	113	55631
1.75	16	38	3361	55633
1.80	16	38	114	55635
1.85	16	38	115	55637
1.90	16	38	116	55639
1.95	16	38	3362	55641



DIXI 1133 R

D_{h5}	L_1	L	CARBURE	DICUT
2.00	16	38	117	55643
2.10	16	38	118	55645
2.20	16	40	119	55647
2.30	16	40	120	55649
2.40	16	43	121	55651
2.50	16	43	122	55653
2.60	16	43	35575	55655
3.00	16	46	35726	55657
3.30	18	49	35665	55659
3.50	20	50	35727	55661
4.00	22	55	34062	55663
4.20	22	55	35728	55665
4.50	24	58	35729	55667
5.00	26	62	35730	55669
5.50	28	66	45735	55671
6.00	28	66	45736	55673



P. 71



P. 84

Acier + Pb	Acier faibl. allié	Acier fort. allié	Acier inox aust.	Fontes
Titane, alliage de titane	Alliage Cu Argent Or	Alliage Cu difficile	Alu	Plastique

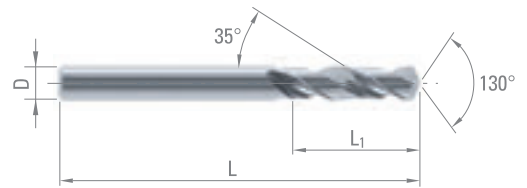

DIXI 1131 R

FORETS HÉLICOÏDAUX
CORPS RENFORCÉ

Z = 2



P. 71



P. 80



DIN
1899

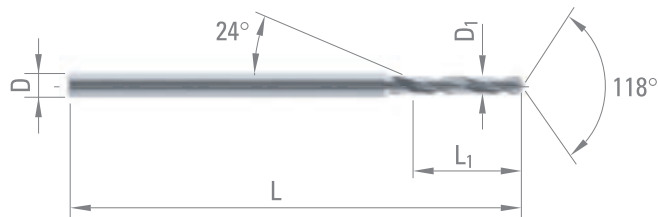

Acier + Pb	Acier faibl. allié	Acier fort. allié	Acier inox aust.	Fontes
Super alliages Ni / Co	Titane, alliage de titane	Alliage Cu Argent Or	Alliage Cu difficile	Alu
Graphite	Plastique			

D ₁ 0/-0.004	L ₁	D _{h5}	L	CARBURE	DICUT	DLC
0.05	0.35	1.0	30	962703		
0.06	0.4	1.0	30	962702		
0.07	0.5	1.0	30	962701		
0.08	0.6	1.0	30	962700		
0.09	0.65	1.0	30	962699		
0.10	0.7	1.0	30	36792		
0.11	0.7	1.0	30	40829		
0.12	0.7	1.0	30	40627		
0.13	0.7	1.0	30	40628		
0.14	0.7	1.0	30	40629		
0.15	1.0	1.0	30	35600		
0.16	1.0	1.0	30	38658		
0.17	1.0	1.0	30	38659		
0.18	1.0	1.0	30	38660		
0.19	1.0	1.0	30	38661		
0.20	1.0	1.0	30	26824	952580	955953
0.21	1.0	1.0	30	29609	952581	955954
0.22	1.0	1.0	30	29610	952582	955955
0.23	1.0	1.0	30	29611	950087	955956
0.23 >	2.2	1.0	30	62513	952583	962712
0.24	1.0	1.0	30	25957	952496	955957
0.24 >	2.2	1.0	30	62514	952584	962713
0.25	1.0	1.0	30	28712	950088	955958
0.25 >	2.2	1.0	30	38282	952585	962714
0.26	1.0	1.0	30	38665	952587	955959
0.27	1.0	1.0	30	37358	952588	955960
0.28	1.0	1.0	30	37258	952589	955961
0.29	1.0	1.0	30	30568	952590	955962
0.30	1.5	1.0	30	28713	952591	955963
0.31	1.5	1.0	30	35421	952592	955964
0.32	1.5	1.0	30	38662	952593	955965
0.32 >	3.0	1.0	30	62515	952594	962715
0.33	1.5	1.0	30	38663	952595	955966
0.33 >	3.0	1.0	30	62516	952596	962716
0.34	1.5	1.0	30	29570	952597	955967
0.34 >	3.0	1.0	30	62517	952598	962717
0.35	1.5	1.0	30	31747	952599	955968
0.36	1.5	1.0	30	39018	952600	955970
0.37	1.5	1.0	30	40633	952601	955971
0.38	1.5	1.0	30	40634	952602	955972
0.39	1.5	1.0	30	40635	952603	955973



DIXI 1131 R

$D_{10/0.004}$	L_1	D_{h5}	L	CARBURE	DICUT	DLC
0.40	2.0	1.0	30	25992	63706	955974
0.41	2.0	1.0	30	29571	952604	955975
0.42	2.0	1.0	30	38419	952605	955976
0.43	2.0	1.0	30	35804	950186	955977
0.44	2.0	1.0	30	40636	952606	955978
0.45	3.6	1.0	30	45726	59562	955979
0.46	3.6	1.0	30	45727	952607	955980
0.47	3.6	1.0	30	45728	952497	955981
0.48	3.6	1.0	30	45729	952608	955982
0.49	4.0	1.0	30	45730	952609	955983
0.50	4.0	1.0	30	25994	55141	955984
0.51	4.0	1.0	30	45731	55142	955985
0.52	4.0	1.0	30	45732	55143	955986
0.53	4.0	1.0	30	45733	55144	955987
0.54	4.5	1.0	30	40640	55145	955988
0.55	4.5	1.0	30	28375	55146	955989
0.56	4.5	1.0	30	41925	55147	955990
0.57	4.5	1.0	30	40641	55148	955991
0.58	4.5	1.0	30	40642	55149	955993
0.59	4.5	1.0	30	40643	55150	955997
0.60	4.5	1.0	30	29643	55151	956048
0.61	5.0	1.0	30	37639	55152	956049
0.62	5.0	1.0	30	25270	55153	956050
0.63	5.0	1.0	30	40644	55154	956051
0.64	5.0	1.0	30	40645	55155	956052
0.65	5.0	1.0	30	41679	55156	956053
0.66	5.0	1.0	30	41886	55157	956054
0.67	5.0	1.0	30	42286	55158	956055
0.68	5.6	1.0	30	42287	55159	956056
0.69	5.6	1.0	30	41788	55160	956057
0.70	5.6	1.0	30	32099	55161	956058
0.71	5.6	1.0	30	42288	55162	956059
0.72	5.6	1.0	30	40983	55163	956060
0.73	5.6	1.0	30	35422	55164	956061
0.74	5.6	1.0	30	36102	55165	956062
0.75	5.6	1.0	30	35423	55166	956063
0.76	6.3	1.0	30	18579	55167	956064
0.77	6.3	1.0	30	42706	55168	956065
0.78	6.3	1.0	30	41887	55169	956066
0.79	6.3	1.0	30	36640	55170	956068
0.80	6.3	1.5	30	402	55171	956069
0.81	6.3	1.5	30	36144	55172	956070
0.82	6.3	1.5	30	34510	55173	956071
0.83	6.3	1.5	30	42290	55174	956072
0.84	6.3	1.5	30	27400	55175	956074
0.85	6.3	1.5	30	35551	55176	956075
0.86	7.1	1.5	30	29254	55177	956076
0.87	7.1	1.5	30	42291	55178	956077
0.88	7.1	1.5	30	19601	55179	956080
0.89	7.1	1.5	30	41789	55180	956081



P. 71



P. 80



Acier + Pb	Acier faibl. allié	Acier fort. allié	Acier inox aust.	Fontes
Super alliages Ni / Co	Titane, alliage de titane	Alliage Cu Argent Or	Alliage Cu difficile	Alu
Graphite	Plastique			

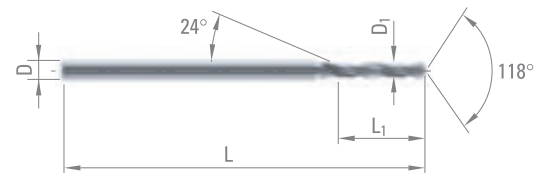

DIXI 1131 R

$D_{10/0.004}$	L_1	D_{h5}	L	CARBURE	DICUT	DLC
0.90	7.1	1.5	30	32100	55181	956082
0.91	7.1	1.5	30	42292	55182	956083
0.92	7.1	1.5	30	36859	55183	956084
0.93	7.1	1.5	30	42293	55184	956085
0.94	7.1	1.5	30	42167	55185	956086
0.95	7.1	1.5	30	35183	55186	956087
0.96	8.0	1.5	30	37741	55188	956088
0.97	8.0	1.5	30	29255	55189	956089
0.98	8.0	1.5	30	42294	55190	956091
0.99	8.0	1.5	30	41790	55191	956092
1.00	9.0	1.5	30	406	55192	956093
1.01	9.0	1.5	30	34996	55193	956094
1.02	9.0	1.5	30	42876	55195	956095
1.03	9.0	1.5	30	34778	55196	956096
1.04	9.0	1.5	30	43984	55200	956097
1.05	9.0	1.5	30	4774	55201	956098
1.06	9.0	1.5	30	43985	55202	956099
1.07	9.0	1.5	30	42228	55203	956100
1.08	9.0	1.5	30	43198	55204	956101
1.09	9.0	1.5	30	28779	55205	956102
1.10	9.0	1.5	30	407	55206	956103
1.11	9.0	1.5	30	43986	55207	956104
1.12	9.0	1.5	30	43347	55208	956105
1.13	9.0	1.5	30	42853	55209	956106
1.14	9.0	1.5	30	43987	55210	956107
1.15	9.0	1.5	30	3530	55211	956108
1.16	9.0	1.5	30	22712	55212	956109
1.17	9.0	1.5	30	4775	55213	956110
1.18	9.0	1.5	30	42230	55214	956111
1.19	10.0	1.5	30	41791	55215	956112
1.20	10.0	1.5	30	408	55216	956113
1.21	10.0	1.5	30	42168	55217	956114
1.22	10.0	1.5	30	25751	55218	956115
1.23	10.0	1.5	30	23285	55219	956116
1.24	10.0	1.5	30	45524	55220	956118
1.25	10.0	1.5	30	3531	55221	956119
1.26	10.0	1.5	30	42005	55222	956120
1.27	10.0	1.5	30	3761	55223	956121
1.28	10.0	1.5	30	42169	55224	956122
1.29	10.0	1.5	30	37694	55225	956124
1.30	10.0	1.5	30	409	55226	956125
1.31	10.0	1.5	30	45525	55227	956128
1.32	10.0	1.5	30	29712	55228	956130
1.33	11.2	1.5	30	34695	55229	956131
1.34	11.2	1.5	30	45526	55230	956132
1.35	11.2	1.5	30	3532	55231	956133
1.36	11.2	1.5	30	45527	55232	956134
1.37	11.2	1.5	30	35556	55233	956135
1.38	11.2	1.5	30	45055	55234	956136
1.39	11.2	1.5	30	45297	55235	956137



P. 71



P. 80



Acier + Pb	Acier faibl. allié	Acier fort. allié	Acier inox aust.	Fontes
Super alliages Ni / Co	Titane, alliage de titane	Alliage Cu Argent Or	Alliage Cu difficile	Alu
Graphite	Plastique			

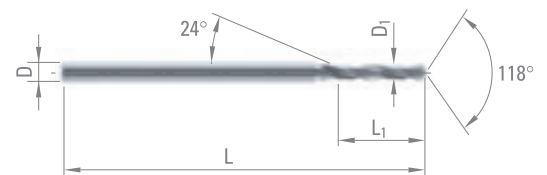

DIXI 1131 R

$D_{10/0.004}$	L_1	D_{h5}	L	CARBURE	DICUT	DLC
1.40	11.2	1.5	30	410	55236	956138
1.41	11.2	1.5	30	33499	55237	956139
1.42	11.2	1.5	30	43348	55238	956140
1.43	11.2	1.5	30	45056	55239	956141
1.44	11.2	1.5	30	45528	55240	956142
1.45	11.2	1.5	30	36006	55241	956143
1.46	11.2	1.5	30	45529	55242	956144
1.47	11.2	1.5	30	45530	55243	956145
1.48	11.2	1.5	30	45057	55244	956146
1.49	11.2	1.5	30	35681	55245	956147
1.50	11.2	2.0	38	411	55246	956148
1.51	12.0	2.0	38	27735	55247	956149
1.52	12.0	2.0	38	27736	55248	956150
1.53	12.0	2.0	38	23286	55249	956151
1.54	12.0	2.0	38	45909	55250	956152
1.55	12.0	2.0	38	25686	55251	956153
1.56	12.0	2.0	38	58194	58196	956154
1.57	12.0	2.0	38	55541	58193	956155
1.58	12.0	2.0	38	39953	55252	956156
1.59	12.0	2.0	38	34993	55253	956157
1.60	12.0	2.0	38	412	55254	956158
1.61	12.0	2.0	38	40288	55255	956159
1.62	12.0	2.0	38	46968	55256	956160
1.63	12.0	2.0	38	45605	55257	956161
1.64	12.0	2.0	38	45910	55258	956162
1.65	12.0	2.0	38	32283	55259	956163
1.66	12.0	2.0	38	47198	55260	956164
1.67	12.0	2.0	38	50763	55261	956165
1.68	12.0	2.0	38	31684	55262	956166
1.69	12.0	2.0	38	45339	55263	956167
1.70	12.0	2.0	38	413	55264	956169
1.71	12.0	2.0	38	45911	55265	956175
1.72	12.0	2.0	38	27925	55266	956177
1.73	12.0	2.0	38	42609	55267	956178
1.74	12.0	2.0	38	45912	55268	956179
1.75	12.0	2.0	38	45734	55269	956180
1.76	12.0	2.0	38	45913	55270	956181
1.77	12.0	2.0	38	38757	61408	956182
1.78	12.0	2.0	38	46957	55271	956183
1.79	12.0	2.0	38	45340	55272	956185
1.80	12.0	2.0	38	31497	55273	956186
1.81	12.0	2.0	38	45914	55274	956187
1.82	12.0	2.0	38	46969	55275	956188
1.83	12.0	2.0	38	58717	61407	956189
1.84	12.0	2.0	38	46970	55276	956190
1.85	12.0	2.0	38	36793	55277	956191
1.86	12.0	2.0	38	50761	55278	956192
1.87	12.0	2.0	38	36487	55279	956195
1.88	12.0	2.0	38	45801	55280	956196
1.89	12.0	2.0	38	45341	55281	956197



P. 71



P. 80



Acier + Pb	Acier faibl. allié	Acier fort. allié	Acier inox aust.	Fontes
Super alliages Ni / Co	Titane, alliage de titane	Alliage Cu Argent Or	Alliage Cu difficile	Alu
Graphite	Plastique			

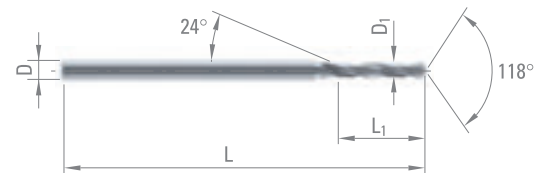

DIXI 1131 R

$D_{10/0.004}$	L_1	D_{h5}	L	CARBURE	DICUT	DLC
1.90	12.0	2.0	38	415	55282	956198
1.91	12.0	2.0	38	45915	55283	956200
1.92	12.0	2.0	38	45916	55284	956201
1.93	12.0	2.0	38	44853	55285	956202
1.94	12.0	2.0	38	45917	55286	956203
1.95	12.0	2.0	38	32284	55287	956204
1.96	12.0	2.0	38	60692	61404	956205
1.97	12.0	2.0	38	50332	61401	956206
1.98	12.0	2.0	38	46959	55288	956207
1.99	12.0	2.0	38	45342	55289	956208
2.00	12.0	2.5	43	416	55290	956209
2.01	12.0	2.5	43	45498	55291	956210
2.02	12.0	2.5	43	48962	61399	956211
2.03	12.0	2.5	43	50685	55292	956212
2.04	12.0	2.5	43	60958	60962	956213
2.05	12.0	2.5	43	40813	55293	956214
2.10	12.0	2.5	43	42295	55294	956215
2.15	12.0	2.5	43	40814	55295	956216
2.20	12.0	2.5	43	418	55296	956217
2.25	12.0	2.5	43	40815	55297	956218
2.30	12.0	2.5	43	419	55298	956219
2.34	12.0	2.5	43	955569	955572	956228
2.35	12.0	2.5	43	6341	55299	956220
2.40	12.0	2.5	43	420	55300	956221
2.45	12.0	2.5	43	40816	55301	956222



P. 71



P. 80



Acier + Pb	Acier faibl. allié	Acier fort. allié	Acier inox aust.	Fontes
Super alliages Ni / Co	Titane, alliage de titane	Alliage Cu Argent Or	Alliage Cu difficile	Alu
Graphite	Plastique			

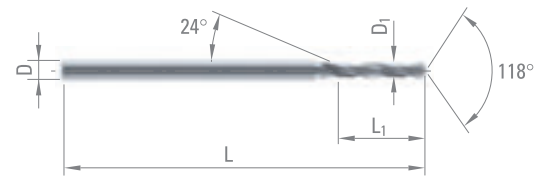



P. 71



P. 80



DIN
1899

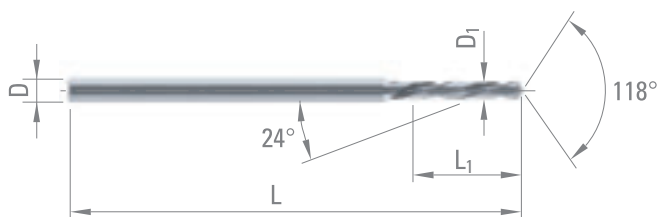

Acier + Pb	Acier faibl. allié	Acier fort. allié	Acier inox aust.	Fontes
Super alliages Ni / Co	Titane, alliage de titane	Alliage Cu Argent Or	Alliage Cu difficile	Alu
Graphite	Plastique			

D ₁ 0/-0.004	L ₁	D _{h5}	L	CARBURE	DICUT
0.10	0.7	1.0	30	36916	
0.11	0.7	1.0	30	36917	
0.12	0.7	1.0	30	36918	
0.13	0.7	1.0	30	36919	
0.14	0.7	1.0	30	36920	
0.15	1.0	1.0	30	36921	
0.16	1.0	1.0	30	36922	
0.17	1.0	1.0	30	38654	
0.18	1.0	1.0	30	36924	
0.19	1.0	1.0	30	36925	
0.20	1.0	1.0	30	36926	952652
0.21	1.0	1.0	30	36927	952653
0.22	1.0	1.0	30	36928	952654
0.23	1.0	1.0	30	36929	952655
0.24	1.0	1.0	30	36930	952656
0.25	1.0	1.0	30	36931	952657
0.26	1.0	1.0	30	36932	952658
0.27	1.0	1.0	30	36933	952659
0.28	1.0	1.0	30	36934	952660
0.29	1.0	1.0	30	36935	952661
0.30	1.5	1.0	30	36936	952662
0.31	1.5	1.0	30	36937	952663
0.32	1.5	1.0	30	36938	952664
0.33	1.5	1.0	30	36939	952665
0.34	1.5	1.0	30	36940	952666
0.35	1.5	1.0	30	36941	952667
0.36	1.5	1.0	30	36942	952669
0.37	1.5	1.0	30	36943	952672
0.38	1.5	1.0	30	36944	952673
0.39	1.5	1.0	30	36945	952674
0.40	2.0	1.0	30	15026	952676
0.41	2.0	1.0	30	35708	952677
0.42	2.0	1.0	30	36946	952678
0.43	2.0	1.0	30	36947	952679
0.44	2.0	1.0	30	36948	952680
0.45	3.6	1.0	30	38054	952681
0.46	3.6	1.0	30	38057	952682
0.47	3.6	1.0	30	38059	952683
0.48	3.6	1.0	30	38062	952684
0.49	4.0	1.0	30	38063	952685



DIXI 1131 L

$D_{10/0.004}$	L_1	D_{h5}	L	CARBURE	DICUT
0.50	4.0	1.0	30	38065	55302
0.51	4.0	1.0	30	38066	55303
0.52	4.0	1.0	30	38068	55304
0.53	4.0	1.0	30	38069	55305
0.54	4.5	1.0	30	38245	55306
0.55	4.5	1.0	30	38246	55307
0.56	4.5	1.0	30	38190	55308
0.57	4.5	1.0	30	38187	55309
0.58	4.5	1.0	30	38103	55310
0.59	4.5	1.0	30	38070	55311
0.60	4.5	1.0	30	38188	55312
0.61	5.0	1.0	30	38247	55313
0.62	5.0	1.0	30	38364	55314
0.63	5.0	1.0	30	38072	55315
0.64	5.0	1.0	30	38073	55316
0.65	5.0	1.0	30	38075	55317
0.66	5.0	1.0	30	36966	55318
0.67	5.0	1.0	30	36838	55319
0.68	5.6	1.0	30	21766	55320
0.69	5.6	1.0	30	4021	55321
0.70	5.6	1.0	30	450	55322
0.71	5.6	1.0	30	38078	55323
0.72	5.6	1.0	30	38182	55324
0.73	5.6	1.0	30	22294	55325
0.74	5.6	1.0	30	38080	55326
0.75	5.6	1.0	30	36975	55327
0.76	6.3	1.0	30	36976	55328
0.77	6.3	1.0	30	40866	55329
0.78	6.3	1.0	30	36978	55330
0.79	6.3	1.0	30	38082	55331
0.80	6.3	1.5	30	38317	55332
0.81	6.3	1.5	30	36981	55333
0.82	6.3	1.5	30	36982	55334
0.83	6.3	1.5	30	36983	55335
0.84	6.3	1.5	30	38292	55336
0.85	6.3	1.5	30	38293	55337
0.86	7.1	1.5	30	38294	55338
0.87	7.1	1.5	30	38251	55339
0.88	7.1	1.5	30	36988	55340
0.89	7.1	1.5	30	36989	55341
0.90	7.1	1.5	30	24182	55342
0.91	7.1	1.5	30	38295	55343
0.92	7.1	1.5	30	36360	55344
0.93	7.1	1.5	30	35871	55345
0.94	7.1	1.5	30	38086	55346
0.95	7.1	1.5	30	455	55347
0.96	8.0	1.5	30	38296	55348
0.97	8.0	1.5	30	36996	55349
0.98	8.0	1.5	30	36997	55350
0.99	8.0	1.5	30	36998	55351
1.00	9.0	1.5	30	36999	55352
1.01	9.0	1.5	30	37000	55353
1.02	9.0	1.5	30	37001	55354
1.03	9.0	1.5	30	37002	55355
1.04	9.0	1.5	30	37003	55356



P. 71



P. 80



Acier + Pb	Acier faibl. allié	Acier fort. allié	Acier inox aust.	Fontes
Super alliages Ni / Co	Titane, alliage de titane	Alliage Cu Argent Or	Alliage Cu difficile	Alu
Graphite	Plastique			

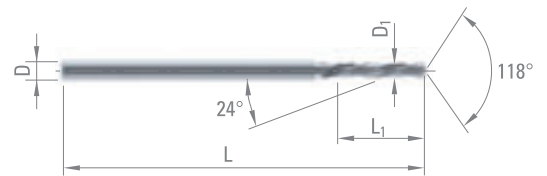

DIXI 1131 L

$D_{10/0.004}$	L_1	D_{h5}	L	CARBURE	DICUT
1.05	9.0	1.5	30	37004	55357
1.06	9.0	1.5	30	37005	55358
1.07	9.0	1.5	30	37006	55359
1.08	9.0	1.5	30	37007	55360
1.09	9.0	1.5	30	37008	55361
1.10	9.0	1.5	30	457	55362
1.11	9.0	1.5	30	37009	55363
1.12	9.0	1.5	30	37010	55364
1.13	9.0	1.5	30	14573	55365
1.14	9.0	1.5	30	37011	55366
1.15	9.0	1.5	30	19337	55367
1.16	9.0	1.5	30	37012	55368
1.17	9.0	1.5	30	37013	55369
1.18	9.0	1.5	30	37014	55370
1.19	10.0	1.5	30	37015	55371
1.20	10.0	1.5	30	37016	55372
1.21	10.0	1.5	30	26225	55373
1.22	10.0	1.5	30	37017	55374
1.23	10.0	1.5	30	45717	55375
1.24	10.0	1.5	30	37019	55376
1.25	10.0	1.5	30	26763	55377
1.26	10.0	1.5	30	27862	55378
1.27	10.0	1.5	30	6197	55379
1.28	10.0	1.5	30	25663	55380
1.29	10.0	1.5	30	27863	55381
1.30	10.0	1.5	30	459	55382
1.31	10.0	1.5	30	37020	55383
1.32	10.0	1.5	30	37021	55384
1.33	11.2	1.5	30	37022	55385
1.34	11.2	1.5	30	45718	55386
1.35	11.2	1.5	30	37024	55387
1.36	11.2	1.5	30	37025	55388
1.37	11.2	1.5	30	37026	55389
1.38	11.2	1.5	30	37027	55390
1.39	11.2	1.5	30	37028	55391
1.40	11.2	1.5	30	460	55392
1.41	11.2	1.5	30	26226	55393
1.42	11.2	1.5	30	37029	55394
1.43	11.2	1.5	30	37030	55395
1.44	11.2	1.5	30	37031	55396
1.45	11.2	1.5	30	26459	55397
1.46	11.2	1.5	30	37032	55398
1.47	11.2	1.5	30	37033	55399
1.48	11.2	1.5	30	37034	55400
1.49	11.2	1.5	30	37035	55401
1.50	11.2	2.0	38	461	55402
1.51	12.0	2.0	38	38089	55403
1.52	12.0	2.0	38	38962	55404
1.53	12.0	2.0	38	38938	55405
1.54	12.0	2.0	38	45531	55406
1.55	12.0	2.0	38	38090	55407
1.56	12.0	2.0	38	45532	55408
1.57	12.0	2.0	38	45351	55409
1.58	12.0	2.0	38	38252	55410
1.59	12.0	2.0	38	45533	55411



P. 71



P. 80



Acier + Pb	Acier faibl. allié	Acier fort. allié	Acier inox aust.	Fontes
Super alliages Ni / Co	Titane, alliage de titane	Alliage Cu Argent Or	Alliage Cu difficile	Alu
Graphite	Plastique			

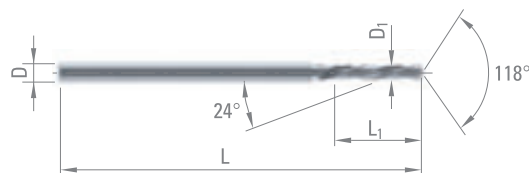

DIXI 1131 L

$D_{10/0.004}$	L_1	D_{h5}	L	CARBURE	DICUT
1.60	12.0	2.0	38	37234	55412
1.61	12.0	2.0	38	40655	55413
1.62	12.0	2.0	38	29286	55414
1.63	12.0	2.0	38	40910	55415
1.64	12.0	2.0	38	41297	55416
1.65	12.0	2.0	38	37235	55417
1.66	12.0	2.0	38	45534	55418
1.67	12.0	2.0	38	44015	55419
1.68	12.0	2.0	38	38092	55420
1.69	12.0	2.0	38	45535	55421
1.70	12.0	2.0	38	463	55422
1.71	12.0	2.0	38	45536	55423
1.72	12.0	2.0	38	45075	55424
1.73	12.0	2.0	38	43415	55425
1.74	12.0	2.0	38	45537	55426
1.75	12.0	2.0	38	38093	55427
1.76	12.0	2.0	38	58052	58054
1.77	12.0	2.0	38	42174	55428
1.78	12.0	2.0	38	57881	57888
1.79	12.0	2.0	38	58197	58199
1.80	12.0	2.0	38	464	55429
1.81	12.0	2.0	38	58636	61392
1.82	12.0	2.0	38	26183	55430
1.83	12.0	2.0	38	61388	61390
1.84	12.0	2.0	38	50611	55431
1.85	12.0	2.0	38	38094	55432
1.86	12.0	2.0	38	61385	61387
1.87	12.0	2.0	38	42119	55433
1.88	12.0	2.0	38	61382	61384
1.89	12.0	2.0	38	50657	55434
1.90	12.0	2.0	38	41217	55435
1.91	12.0	2.0	38	61150	61367
1.92	12.0	2.0	38	48963	57890
1.93	12.0	2.0	38	50158	58056
1.94	12.0	2.0	38	60780	60782
1.95	12.0	2.0	38	45719	55436
1.96	12.0	2.0	38	61368	61370
1.97	12.0	2.0	38	61372	61371
1.98	12.0	2.0	38	44254	57892
1.99	12.0	2.0	38	58741	60784
2.00	12.0	2.5	43	466	55437
2.01	12.0	2.5	43	38096	55438
2.02	12.0	2.5	43	47857	55439
2.03	12.0	2.5	43	61256	61375
2.04	12.0	2.5	43	61376	61378
2.05	12.0	2.5	43	61379	61381
2.10	12.0	2.5	43	467	55440
2.12	12.0	2.5	43	47858	55441
2.15	12.0	2.5	43	38097	55442
2.45	12.0	2.5	43	38098	55443



P. 71



P. 80



Acier + Pb	Acier faibl. allié	Acier fort. allié	Acier inox aust.	Fontes
Super alliages Ni / Co	Titane, alliage de titane	Alliage Cu Argent Or	Alliage Cu difficile	Alu
Graphite	Plastique			

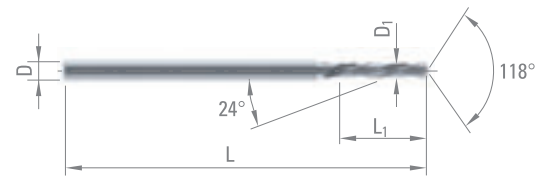

DIXI 1134 R

FORETS HÉLICOÏDAUX
CORPS RENFORCÉ

Z = 2



P. 71



P. 82



DIN
1899

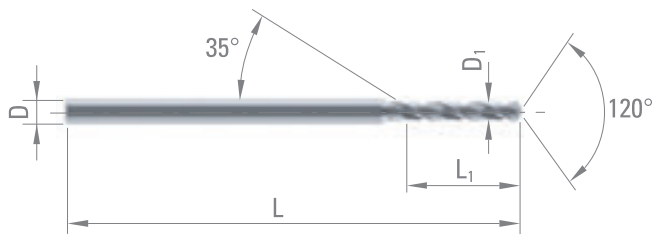

Acier + Pb	Acier faibl. allié	Acier fort. allié	Acier inox aust.	Fontes
Super alliages Ni / Co	Titane, alliage de titane	Alliage Cu Argent Or	Alliage Cu difficile	Alu

D _{1 0/-0.004}	L ₁	D _{h5}	L	CARBURE	DICUT
0.50	4.0	1.0	30	21228	57565
0.55	4.5	1.0	30	39029	57566
0.60	4.5	1.0	30	176	57567
0.65	5.0	1.0	30	39030	57568
0.70	5.6	1.0	30	178	55679
0.75	5.6	1.0	30	39031	55681
0.80	6.3	1.5	30	180	55683
0.81	6.3	1.5	30	957990	957991
0.82	6.3	1.5	30	957040	957994
0.83	6.3	1.5	30	45775	957802
0.84	6.3	1.5	30	45776	957804
0.85	6.3	1.5	30	181	55685
0.86	7.1	1.5	30	957995	957996
0.87	7.1	1.5	30	957998	957999
0.88	7.1	1.5	30	958001	958002
0.89	7.1	1.5	30	56626	957806
0.90	7.1	1.5	30	182	55687
0.91	7.1	1.5	30	958006	958007
0.92	7.1	1.5	30	957949	958004
0.93	7.1	1.5	30	957042	957808
0.94	7.1	1.5	30	957043	957810
0.95	7.1	1.5	30	39032	55689
0.96	9.0	1.5	30	49329	957812
0.97	9.0	1.5	30	957045	957829
0.98	9.0	1.5	30	43498	957831
0.99	9.0	1.5	30	61003	957834
1.00	9.0	1.5	30	184	55691
1.01	9.0	1.5	30	48709	957865
1.02	9.0	1.5	30	58334	957867
1.03	9.0	1.5	30	958010	958011
1.04	9.0	1.5	30	958013	958015
1.05	9.0	1.5	30	39033	55757
1.06	9.0	1.5	30	958017	958018
1.07	9.0	1.5	30	58335	957879
1.08	9.0	1.5	30	57722	957884
1.09	9.0	1.5	30	958020	958021



DIXI 1134 R

$D_{10/0.004}$	L_1	D_{h5}	L	CARBURE	DICUT
1.10	9.0	1.5	30	39034	55759
1.11	9.0	1.5	30	45752	957887
1.12	9.0	1.5	30	62921	954726
1.13	9.0	1.5	30	957889	954727
1.14	9.0	1.5	30	958023	958024
1.15	9.0	1.5	30	39035	55761
1.16	10.0	1.5	30	50299	957893
1.17	10.0	1.5	30	52449	957895
1.18	10.0	1.5	30	58333	957897
1.19	10.0	1.5	30	958026	958027
1.20	10.0	1.5	30	39036	55762
1.21	10.0	1.5	30	50233	957899
1.22	10.0	1.5	30	59610	957901
1.23	10.0	1.5	30	46797	957902
1.24	10.0	1.5	30	958029	958030
1.25	10.0	1.5	30	39037	55764
1.26	10.0	1.5	30	65858	50057
1.27	10.0	1.5	30	50558	957912
1.28	10.0	1.5	30	958032	958033
1.29	10.0	1.5	30	958035	958037
1.30	10.0	1.5	30	187	55766
1.31	11.2	1.5	30	958199	958200
1.32	11.2	1.5	30	50068	957914
1.33	11.2	1.5	30	44387	957916
1.34	11.2	1.5	30	53518	958203
1.35	11.2	1.5	30	39038	55768
1.36	11.2	1.5	30	58147	957921
1.37	11.2	1.5	30	958205	958206
1.38	11.2	1.5	30	958208	958209
1.39	11.2	1.5	30	958211	958212
1.40	11.2	1.5	30	188	55777
1.45	11.2	1.5	30	39039	55779
1.50	11.2	2.0	38	39040	55780
1.55	12.0	2.0	38	52209	55782
1.60	12.0	2.0	38	52210	55786
1.65	12.0	2.0	38	52211	54986
1.70	12.0	2.0	38	191	55789
1.75	12.0	2.0	38	52212	55791
1.80	12.0	2.0	38	49082	55793
1.85	12.0	2.0	38	52213	55795
1.90	12.0	2.0	38	193	55797
1.95	12.0	2.0	38	52214	55799



P. 71



P. 82



Acier + Pb	Acier faibl. allié	Acier fort. allié	Acier inox aust.	Fontes
Super alliages Ni / Co	Titane, alliage de titane	Alliage Cu Argent Or	Alliage Cu difficile	Alu

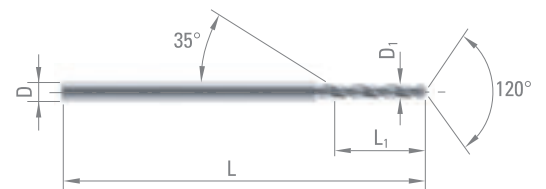

DIXI 1135 R

FORETS HÉLICOÏDAUX
CORPS RENFORCÉ

Z = 2



P. 71



P. 82

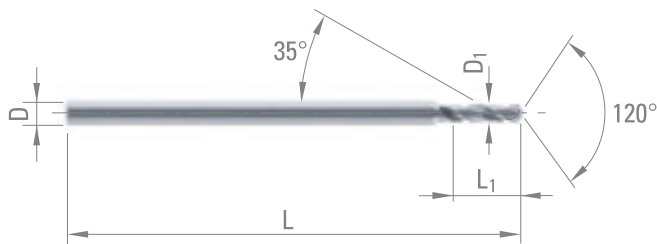

Acier + Pb	Acier faibl. allié	Acier fort. allié	Acier inox aust.	Fontes
Super alliages Ni / Co	Titane, alliage de titane	Alliage Cu Argent Or	Alliage Cu difficile	Alu

$D_{1\ 0/-0.004}$	L_1	D_{h5}	L	CARBURE	DICUT
0.20	1.5	1.5	30	950342	950234
0.21	1.5	1.5	30	950235	950248
0.22	1.5	1.5	30	950236	950249
0.23	1.5	1.5	30	950240	950250
0.24	1.5	1.5	30	950241	950251
0.25	2.0	1.5	30	950253	950278
0.26	2.0	1.5	30	950254	950279
0.27	2.0	1.5	30	950255	950280
0.28	2.0	1.5	30	950256	950281
0.29	2.0	1.5	30	950084	950282
0.30	2.0	1.5	30	950276	950283
0.31	2.5	1.5	30	950284	950299
0.32	2.5	1.5	30	950285	950301
0.33	2.5	1.5	30	950286	950302
0.34	2.5	1.5	30	950287	950303
0.35	2.5	1.5	30	950288	950304
0.36	2.5	1.5	30	950085	950305
0.37	2.5	1.5	30	950289	950306
0.38	2.5	1.5	30	950290	950307
0.39	3.0	1.5	30	950308	950330
0.40	3.0	1.5	30	950309	950331
0.41	3.0	1.5	30	950310	950332
0.42	3.0	1.5	30	950311	950333
0.43	3.0	1.5	30	950312	950334
0.44	3.0	1.5	30	950313	950335
0.45	3.0	1.5	30	950314	950336
0.46	3.0	1.5	30	950315	950337
0.47	3.0	1.5	30	950316	950338
0.48	3.0	1.5	30	950317	950339
0.49	3.0	1.5	30	950318	950340
0.50	4.0	1.5	30	60922	61017
0.51	4.0	1.5	30	60923	61018
0.52	4.0	1.5	30	60924	61020
0.53	4.0	1.5	30	60925	61021
0.54	4.0	1.5	30	60926	61022
0.55	4.0	1.5	30	60927	61023
0.56	4.0	1.5	30	60928	61024
0.57	4.0	1.5	30	60929	61025
0.58	4.0	1.5	30	60930	61026
0.59	4.0	1.5	30	60931	61027



DIXI 1135 R

$D_{10/0.004}$	L_1	D_{h5}	L	CARBURE	DICUT
0.60	4.5	1.5	30	60932	61028
0.61	4.5	1.5	30	60933	61029
0.62	4.5	1.5	30	60934	61030
0.63	4.5	1.5	30	60935	61031
0.64	4.5	1.5	30	60936	61032
0.65	4.5	1.5	30	60937	61033
0.66	4.5	1.5	30	60938	61034
0.67	4.5	1.5	30	60939	61035
0.68	4.5	1.5	30	56623	61036
0.69	4.5	1.5	30	60940	61037
0.70	4.5	1.5	30	56364	57571
0.71	4.5	1.5	30	56365	57573
0.72	4.5	1.5	30	56366	57575
0.73	4.5	1.5	30	56367	57577
0.74	4.5	1.5	30	56368	57587
0.75	4.5	1.5	30	56369	57589
0.76	4.5	1.5	30	56370	57579
0.77	4.5	1.5	30	56371	57581
0.78	4.5	1.5	30	56372	57583
0.79	4.5	1.5	30	56373	57585
0.80	5.0	1.5	30	52140	55801
0.81	5.0	1.5	30	52141	55803
0.82	5.0	1.5	30	52142	55805
0.83	5.0	1.5	30	52143	55807
0.84	5.0	1.5	30	52144	55809
0.85	5.0	1.5	30	52145	55811
0.86	5.0	1.5	30	52146	55813
0.87	5.0	1.5	30	52147	55815
0.88	5.0	1.5	30	52148	55817
0.89	5.0	1.5	30	52149	55819
0.90	5.0	1.5	30	52150	55821
0.91	5.0	1.5	30	52151	55823
0.92	5.0	1.5	30	52152	55825
0.93	5.0	1.5	30	52153	55827
0.94	5.0	1.5	30	52154	55829
0.95	5.0	1.5	30	52155	55831
0.96	5.0	1.5	30	52156	55833
0.97	5.0	1.5	30	52157	55835
0.98	5.0	1.5	30	52158	55837
0.99	5.0	1.5	30	52159	55839
1.00	5.0	1.5	30	52160	55841
1.01	5.0	1.5	30	52161	55842
1.02	5.0	1.5	30	52162	55844
1.03	5.0	1.5	30	52163	55848
1.04	5.0	1.5	30	52164	55850
1.05	5.0	1.5	30	52165	55852
1.06	5.0	1.5	30	52166	55854
1.07	5.0	1.5	30	52167	55856
1.08	5.0	1.5	30	52168	55858
1.09	5.0	1.5	30	52169	55860
1.10	5.0	1.5	30	52170	55861
1.11	5.0	1.5	30	52171	55863
1.12	5.0	1.5	30	52172	55865
1.13	5.0	1.5	30	52173	55871
1.14	5.0	1.5	30	52174	55872



P. 71

P. 82

Acier + Pb	Acier faibl. allié	Acier fort. allié	Acier inox aust.	Fontes
Super alliages Ni / Co	Titane, alliage de titane	Alliage Cu Argent Or	Alliage Cu difficile	Alu

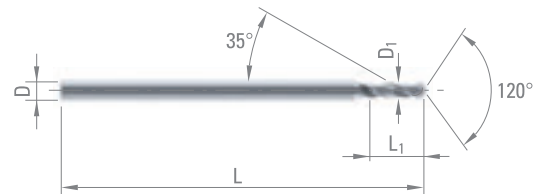

DIXI 1135 R

$D_{10/0.004}$	L_1	D_{h5}	L	CARBURE	DICUT
1.15	5.0	1.5	30	52175	55873
1.16	5.0	1.5	30	52176	55875
1.17	5.0	1.5	30	52177	55877
1.18	5.0	1.5	30	52178	55878
1.19	5.0	1.5	30	52179	55893
1.20	6.0	1.5	30	52180	55880
1.21	6.0	1.5	30	52181	55882
1.22	6.0	1.5	30	52182	55884
1.23	6.0	1.5	30	52183	55886
1.24	6.0	1.5	30	52184	55896
1.25	6.0	1.5	30	52185	55898
1.26	6.0	1.5	30	52186	55900
1.27	6.0	1.5	30	52187	55902
1.28	6.0	1.5	30	52188	55904
1.29	6.0	1.5	30	52189	55906
1.30	6.0	1.5	30	52190	55908
1.31	6.0	1.5	30	52191	55910
1.32	6.0	1.5	30	52192	55912
1.33	6.0	1.5	30	52193	55914
1.34	6.0	1.5	30	52194	55916
1.35	6.0	1.5	30	52195	55918
1.36	6.0	1.5	30	52196	55920
1.37	6.0	1.5	30	52197	55922
1.38	6.0	1.5	30	52198	55924
1.39	6.0	1.5	30	52199	55926
1.40	6.0	1.5	30	52200	55929
1.41	6.0	1.5	30	52201	55932
1.42	6.0	1.5	30	52202	55934
1.43	6.0	1.5	30	52203	55936
1.44	6.0	1.5	30	52204	55938
1.45	6.0	1.5	30	52205	55940
1.46	6.0	1.5	30	52206	55942
1.47	6.0	1.5	30	52207	55944
1.48	6.0	1.5	30	52208	55946
1.49	6.0	1.5	30	52216	55948
1.50	7.0	2.0	38	56431	57591
1.51	7.0	2.0	38	56374	57593
1.52	7.0	2.0	38	56375	57595
1.53	7.0	2.0	38	56376	57597
1.54	7.0	2.0	38	56377	57599
1.55	7.0	2.0	38	56378	57601
1.56	7.0	2.0	38	56379	57603
1.57	7.0	2.0	38	56380	57605
1.58	7.0	2.0	38	56381	57607
1.59	7.0	2.0	38	56382	57609
1.60	7.0	2.0	38	56383	57611
1.61	7.0	2.0	38	56384	57613
1.62	7.0	2.0	38	56385	57615
1.63	7.0	2.0	38	56386	57617
1.64	7.0	2.0	38	56387	57619
1.65	7.0	2.0	38	56388	57621
1.66	7.0	2.0	38	56389	57623
1.67	7.0	2.0	38	56390	57625
1.68	7.0	2.0	38	56391	57627
1.69	7.0	2.0	38	56392	57629



P. 71



P. 82

Acier + Pb	Acier faibl. allié	Acier fort. allié	Acier inox aust.	Fontes
Super alliages Ni / Co	Titane, alliage de titane	Alliage Cu Argent Or	Alliage Cu difficile	Alu

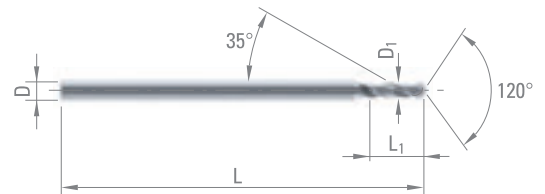

DIXI 1135 R

$D_{10/0.004}$	L_1	D_{h5}	L	CARBURE	DICUT
1.70	7.0	2.0	38	56393	57631
1.71	7.0	2.0	38	56394	57633
1.72	7.0	2.0	38	56395	57635
1.73	7.0	2.0	38	56396	57637
1.74	7.0	2.0	38	56397	57639
1.75	7.0	2.0	38	56398	57641
1.76	8.0	2.0	38	56399	57643
1.77	8.0	2.0	38	56400	57645
1.78	8.0	2.0	38	56401	57647
1.79	8.0	2.0	38	56402	57649
1.80	8.0	2.0	38	56403	57651
1.81	8.0	2.0	38	56404	57653
1.82	8.0	2.0	38	56405	57655
1.83	8.0	2.0	38	56406	57657
1.84	8.0	2.0	38	56407	57659
1.85	8.0	2.0	38	56408	57661
1.86	8.0	2.0	38	56409	57663
1.87	8.0	2.0	38	56410	57665
1.88	8.0	2.0	38	56411	57667
1.89	8.0	2.0	38	56412	57669
1.90	8.0	2.0	38	56413	57671
1.91	8.0	2.0	38	56414	57673
1.92	8.0	2.0	38	56415	57675
1.93	8.0	2.0	38	56416	57677
1.94	8.0	2.0	38	56417	57679
1.95	8.0	2.0	38	56418	57681
1.96	8.0	2.0	38	56419	57683
1.97	8.0	2.0	38	56420	57685
1.98	8.0	2.0	38	56421	57687
1.99	8.0	2.0	38	56422	57689
2.00	9.0	2.5	43	951030	951165
2.01	9.0	2.5	43	951034	951166
2.02	9.0	2.5	43	951035	951167
2.03	9.0	2.5	43	951036	951168
2.04	9.0	2.5	43	951039	951169
2.05	9.0	2.5	43	59122	951170
2.06	9.0	2.5	43	951040	951171
2.07	9.0	2.5	43	951041	951172
2.08	9.0	2.5	43	951042	951173
2.09	9.0	2.5	43	951043	951214
2.10	9.0	2.5	43	951058	951215
2.11	9.0	2.5	43	951059	951216
2.12	9.0	2.5	43	951060	951217
2.13	9.0	2.5	43	951061	951218
2.14	9.0	2.5	43	951062	951219
2.15	9.0	2.5	43	951063	951220
2.16	9.0	2.5	43	951064	951621
2.17	9.0	2.5	43	951065	951622
2.18	9.0	2.5	43	951066	951624
2.19	9.0	2.5	43	951067	951625
2.20	9.0	2.5	43	951068	951626
2.21	9.0	2.5	43	951069	951627
2.22	9.0	2.5	43	951070	951628
2.23	9.0	2.5	43	951071	951629
2.24	9.0	2.5	43	951072	951630



P. 71



P. 82

Acier + Pb	Acier faibl. allié	Acier fort. allié	Acier inox aust.	Fontes
Super alliages Ni / Co	Titane, alliage de titane	Alliage Cu Argent Or	Alliage Cu difficile	Alu

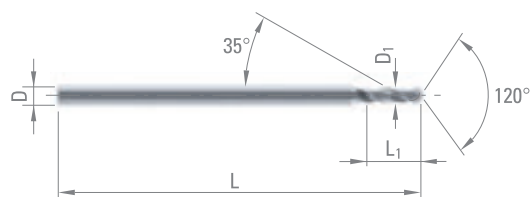

DIXI 1135 R

$D_{10/0.004}$	L_1	D_{h5}	L	CARBURE	DICUT
2.25	9.0	2.5	43	951073	951631
2.26	9.0	2.5	43	951074	951632
2.27	9.0	2.5	43	951075	951633
2.28	9.0	2.5	43	951076	951634
2.29	9.0	2.5	43	951077	951636
2.30	9.0	2.5	43	951078	951637
2.31	9.0	2.5	43	951079	951638
2.32	9.0	2.5	43	951080	951639
2.33	9.0	2.5	43	951081	951640
2.34	9.0	2.5	43	951082	951641
2.35	9.0	2.5	43	951083	951642
2.36	9.0	2.5	43	951084	951643
2.37	9.0	2.5	43	951085	951644
2.38	9.0	2.5	43	951086	951645
2.39	9.0	2.5	43	951087	951646
2.40	9.0	2.5	43	951089	951647
2.41	9.0	2.5	43	951090	951648
2.42	9.0	2.5	43	951091	951649
2.43	9.0	2.5	43	951092	951650
2.44	9.0	2.5	43	951093	951651
2.45	9.0	2.5	43	951094	951652
2.46	9.0	2.5	43	951095	951653
2.47	9.0	2.5	43	951096	951654
2.48	9.0	2.5	43	951097	951655
2.49	9.0	2.5	43	951098	951656



P. 71



P. 82

Acier + Pb	Acier faibl. allié	Acier fort. allié	Acier inox aust.	Fontes
Super alliages Ni / Co	Titane, alliage de titane	Alliage Cu Argent Or	Alliage Cu difficile	Alu

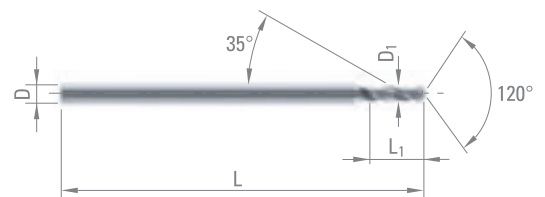

DIXI 1136 R

FORETS HÉLICOÏDAUX
CORPS RENFORCÉ
TOLÉRANCE 0/+4 μ m

Z = 2



P. 71



P. 82

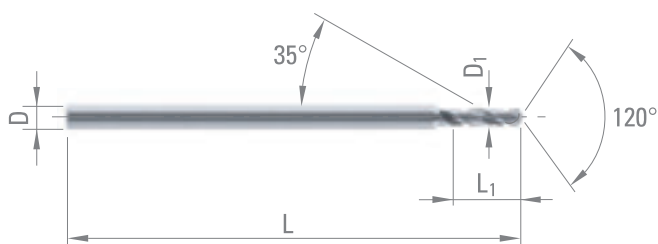

Acier + Pb	Acier faibl. allié	Acier fort. allié	Acier inox aust.	Fontes
Super alliages Ni / Co	Titane, alliage de titane	Alliage Cu Argent Or	Alliage Cu difficile	Alu

D ₁ 0/+0.004	L ₁	D _{h5}	L	CARBURE	DICUT
0.20	1.5	1.5	30	990662	990642
0.21	1.5	1.5	30	990643	990676
0.22	1.5	1.5	30	990644	990677
0.23	1.5	1.5	30	990674	990678
0.24	1.5	1.5	30	990675	990679
0.25	2.0	1.5	30	990680	990659
0.26	2.0	1.5	30	990681	990660
0.27	2.0	1.5	30	990682	990663
0.28	2.0	1.5	30	990683	990664
0.29	2.0	1.5	30	990631	990665
0.30	2.0	1.5	30	990658	990666
0.31	2.5	1.5	30	990667	990645
0.32	2.5	1.5	30	990668	990646
0.33	2.5	1.5	30	990669	990647
0.34	2.5	1.5	30	990670	990648
0.35	2.5	1.5	30	990671	990649
0.36	2.5	1.5	30	990632	990650
0.37	2.5	1.5	30	990672	990651
0.38	2.5	1.5	30	990673	990652
0.39	3.0	1.5	30	990653	990633
0.40	3.0	1.5	30	990654	990634
0.41	3.0	1.5	30	990655	990635
0.42	3.0	1.5	30	990656	990636
0.43	3.0	1.5	30	990684	990637
0.44	3.0	1.5	30	990685	990638
0.45	3.0	1.5	30	990686	990639
0.46	3.0	1.5	30	990687	990640
0.47	3.0	1.5	30	990688	990641
0.48	3.0	1.5	30	990689	990657
0.49	3.0	1.5	30	990690	990661
0.50	4.0	1.5	30	990616	990605
0.51	4.0	1.5	30	990617	990606
0.52	4.0	1.5	30	990618	990607
0.53	4.0	1.5	30	990619	990608
0.54	4.0	1.5	30	990620	990609
0.55	4.0	1.5	30	990621	990610
0.56	4.0	1.5	30	990622	990630
0.57	4.0	1.5	30	990623	990592
0.58	4.0	1.5	30	990624	990593
0.59	4.0	1.5	30	990625	990594



DIXI 1136 R

$D_{10/+0.004}$	L_1	D_{h5}	L	CARBURE	DICUT
0.60	4.5	1.5	30	990626	990595
0.61	4.5	1.5	30	990627	990596
0.62	4.5	1.5	30	990628	990597
0.63	4.5	1.5	30	990629	990598
0.64	4.5	1.5	30	990599	990604
0.65	4.5	1.5	30	990600	990612
0.66	4.5	1.5	30	990601	990613
0.67	4.5	1.5	30	990602	990614
0.68	4.5	1.5	30	990440	990615
0.69	4.5	1.5	30	990603	990611
0.70	4.5	1.5	30	990523	990576
0.71	4.5	1.5	30	990524	990577
0.72	4.5	1.5	30	990525	990578
0.73	4.5	1.5	30	990526	990579
0.74	4.5	1.5	30	990527	990581
0.75	4.5	1.5	30	990528	990582
0.76	4.5	1.5	30	990529	990588
0.77	4.5	1.5	30	990530	990589
0.78	4.5	1.5	30	990531	990590
0.79	4.5	1.5	30	990532	990591
0.80	5.0	1.5	30	990426	990485
0.81	5.0	1.5	30	990410	990550
0.82	5.0	1.5	30	990411	990551
0.83	5.0	1.5	30	990412	990552
0.84	5.0	1.5	30	990413	990470
0.85	5.0	1.5	30	990414	990471
0.86	5.0	1.5	30	990415	990472
0.87	5.0	1.5	30	990416	990473
0.88	5.0	1.5	30	990417	990504
0.89	5.0	1.5	30	990418	990505
0.90	5.0	1.5	30	990419	990506
0.91	5.0	1.5	30	990420	990507
0.92	5.0	1.5	30	990421	990508
0.93	5.0	1.5	30	990422	990509
0.94	5.0	1.5	30	990423	990510
0.95	5.0	1.5	30	990424	990511
0.96	5.0	1.5	30	990425	990512
0.97	5.0	1.5	30	990444	990474
0.98	5.0	1.5	30	990445	990475
0.99	5.0	1.5	30	990446	990476
1.00	5.0	1.5	30	990447	990477
1.01	5.0	1.5	30	990448	990478
1.02	5.0	1.5	30	990339	990479
1.03	5.0	1.5	30	990340	990480
1.04	5.0	1.5	30	990341	990543
1.05	5.0	1.5	30	990441	990544
1.06	5.0	1.5	30	990442	990449
1.07	5.0	1.5	30	990443	990488
1.08	5.0	1.5	30	990427	990489
1.09	5.0	1.5	30	990428	990490
1.10	5.0	1.5	30	990429	990491
1.11	5.0	1.5	30	990430	990492
1.12	5.0	1.5	30	990431	990493
1.13	5.0	1.5	30	990432	990494
1.14	5.0	1.5	30	990433	990495
1.15	5.0	1.5	30	990434	990496



P. 71

P. 82

Acier + Pb	Acier faibl. allié	Acier fort. allié	Acier inox aust.	Fontes
Super alliages Ni / Co	Titane, alliage de titane	Alliage Cu Argent Or	Alliage Cu difficile	Alu

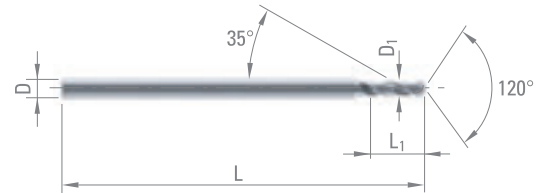

DIXI 1136 R

$D_{10/+0.004}$	L_1	D_{h5}	L	CARBURE	DICUT
1.16	5.0	1.5	30	990435	990497
1.17	5.0	1.5	30	990436	990498
1.18	5.0	1.5	30	990437	990499
1.19	5.0	1.5	30	990438	990466
1.20	6.0	1.5	30	990439	990500
1.21	6.0	1.5	30	990342	990371
1.22	6.0	1.5	30	990343	990372
1.23	6.0	1.5	30	990344	990373
1.24	6.0	1.5	30	990345	990517
1.25	6.0	1.5	30	990346	990518
1.26	6.0	1.5	30	990347	990368
1.27	6.0	1.5	30	990348	990369
1.28	6.0	1.5	30	990349	990370
1.29	6.0	1.5	30	990350	990458
1.30	6.0	1.5	30	990351	990459
1.31	6.0	1.5	30	990352	990460
1.32	6.0	1.5	30	990353	990461
1.33	6.0	1.5	30	990354	990462
1.34	6.0	1.5	30	990355	990463
1.35	6.0	1.5	30	990356	990464
1.36	6.0	1.5	30	990357	990465
1.37	6.0	1.5	30	990358	990467
1.38	6.0	1.5	30	990359	990468
1.39	6.0	1.5	30	990360	990469
1.40	6.0	1.5	30	990361	990393
1.41	6.0	1.5	30	990362	990401
1.42	6.0	1.5	30	990363	990402
1.43	6.0	1.5	30	990364	990403
1.44	6.0	1.5	30	990365	990404
1.45	6.0	1.5	30	990366	990405
1.46	6.0	1.5	30	990367	990406
1.47	6.0	1.5	30	990331	990407
1.48	6.0	1.5	30	990332	990408
1.49	6.0	1.5	30	990333	990409
1.50	7.0	2.0	38	990400	990583
1.51	7.0	2.0	38	990533	990584
1.52	7.0	2.0	38	990534	990560
1.53	7.0	2.0	38	990535	990561
1.54	7.0	2.0	38	990536	990481
1.55	7.0	2.0	38	990537	990482
1.56	7.0	2.0	38	990538	990483
1.57	7.0	2.0	38	990539	990484
1.58	7.0	2.0	38	990540	990501
1.59	7.0	2.0	38	990541	990502
1.60	7.0	2.0	38	990542	990503
1.61	7.0	2.0	38	990545	990486
1.62	7.0	2.0	38	990546	990487
1.63	7.0	2.0	38	990547	990513
1.64	7.0	2.0	38	990548	990514
1.65	7.0	2.0	38	990549	990515
1.66	7.0	2.0	38	990519	990516
1.67	7.0	2.0	38	990520	990562
1.68	7.0	2.0	38	990521	990563
1.69	7.0	2.0	38	990522	990564



P. 71

P. 82

Acier + Pb	Acier faibl. allié	Acier fort. allié	Acier inox aust.	Fontes
Super alliages Ni / Co	Titane, alliage de titane	Alliage Cu Argent Or	Alliage Cu difficile	Alu

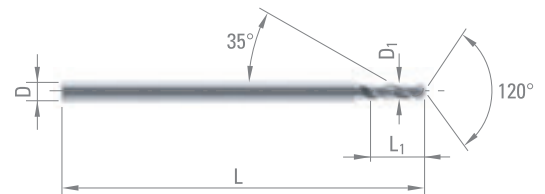

DIXI 1136 R

$D_{10/+0.004}$	L_1	D_{h5}	L	CARBURE	DICUT
1.70	7.0	2.0	38	990374	990565
1.71	7.0	2.0	38	990375	990585
1.72	7.0	2.0	38	990376	990586
1.73	7.0	2.0	38	990377	990587
1.74	7.0	2.0	38	990378	990553
1.75	7.0	2.0	38	990394	990554
1.76	8.0	2.0	38	990395	990555
1.77	8.0	2.0	38	990396	990556
1.78	8.0	2.0	38	990397	990557
1.79	8.0	2.0	38	990398	990558
1.80	8.0	2.0	38	990399	990559
1.81	8.0	2.0	38	990379	990566
1.82	8.0	2.0	38	990380	990567
1.83	8.0	2.0	38	990381	990568
1.84	8.0	2.0	38	990334	990569
1.85	8.0	2.0	38	990335	990570
1.86	8.0	2.0	38	990336	990571
1.87	8.0	2.0	38	990337	990572
1.88	8.0	2.0	38	990338	990573
1.89	8.0	2.0	38	990382	990574
1.90	8.0	2.0	38	990383	990575
1.91	8.0	2.0	38	990384	990450
1.92	8.0	2.0	38	990385	990451
1.93	8.0	2.0	38	990386	990452
1.94	8.0	2.0	38	990387	990453
1.95	8.0	2.0	38	990388	990454
1.96	8.0	2.0	38	990389	990455
1.97	8.0	2.0	38	990390	990456
1.98	8.0	2.0	38	990391	990457
1.99	8.0	2.0	38	990392	990580



P. 71



P. 82

Acier + Pb	Acier faibl. allié	Acier fort. allié	Acier inox aust.	Fontes
Super alliages Ni / Co	Titane, alliage de titane	Alliage Cu Argent Or	Alliage Cu difficile	Alu

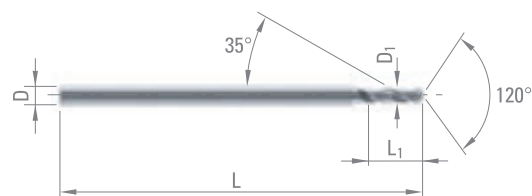

DIXI 1138 R

FORETS HÉLICOÏDAUX CORPS RENFORCÉ

Z = 2



P. 71



P. 82

$\emptyset 0.05 < \emptyset 0.50$

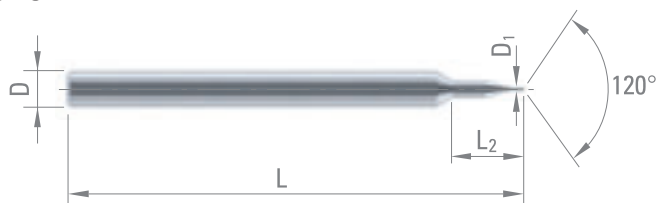

$\emptyset 0.50 \leq \emptyset 2.80$

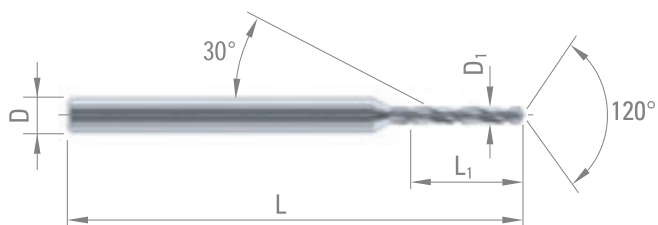

$D_{1\ 0/-0.004}$	L_1	D_2	L_2	D_{h5}	L	CARBURE	TiAIN
0.05	0.35	1.5	5.35	3	38	962810	
0.06	0.40	1.5	5.40	3	38	962809	
0.07	0.50	1.5	5.50	3	38	962808	
0.08	0.60	1.5	5.65	3	38	962807	
0.09	0.65	1.5	5.70	3	38	962806	
0.10	0.70	1.5	5.70	3	38	960016	960258
0.15	1.00	1.5	6.00	3	38	960014	200513
0.20	1.00	1.5	6.00	3	38	960013	200512
0.25	1.00	1.5	6.00	3	38	960012	200511
0.30	1.50	1.5	6.50	3	38	960011	200510
0.35	1.50	1.5	6.50	3	38	960010	200509
0.40	2.00	1.5	7.00	3	38	960009	200508
0.45	3.60	1.5	8.60	3	38	960007	200507

$D_{1\ 0/-0.004}$	L_1	D_{h5}	L	CARBURE	TiAIN
0.50	4.0	3	38	200157	200439
0.53	4.5	3	38	960034	200514
0.55	4.5	3	38	200189	200471
0.60	4.5	3	38	200148	200429
0.62	5.0	3	38	960035	200515
0.65	5.0	3	38	200190	200472
0.70	5.6	3	38	200149	200431
0.71	5.6	3	38	960036	200516
0.75	5.6	3	38	200191	200473
0.80	6.3	3	38	200150	200432
0.81	6.3	3	38	200210	200492
0.82	6.3	3	38	200185	200467
0.83	6.3	3	38	200167	200449
0.84	6.3	3	38	200168	200450
0.85	6.3	3	38	200151	200433
0.86	7.1	3	38	200211	200493
0.87	7.1	3	38	200207	200489
0.88	7.1	3	38	200208	200490
0.89	7.1	3	38	200204	200486
0.90	7.1	3	38	200152	200434
0.91	7.1	3	38	200209	200491
0.92	7.1	3	38	200213	200495
0.93	7.1	3	38	200184	200466
0.94	7.1	3	38	200186	200468
0.95	7.1	3	38	200192	200474
0.96	9.0	3	38	200160	200442
0.97	9.0	3	38	200187	200469
0.98	9.0	3	38	200201	200483
0.99	9.0	3	38	200182	200464
1.00	9.0	3	38	959533	200430
1.01	9.0	3	38	200169	200451

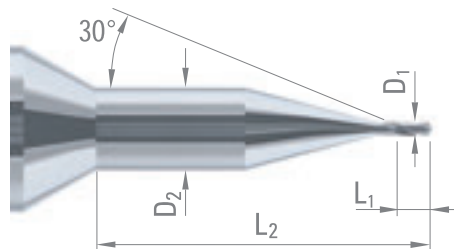

Acier + Pb	Acier faibl. allié	Acier fort. allié	Acier inox aust.	Fontes
Super alliages Ni / Co	Titane, alliage de titane	Alliage Cu Argent Or	Alliage Cu difficile	Alu



DIXI 1138 R

$D_{10/0.004}$	L_1	D_{h5}	L	CARBURE	TiAlN
1.02	9.0	3	38	200178	200460
1.03	9.0	3	38	200214	200496
1.04	9.0	3	38	200215	200497
1.05	9.0	3	38	200193	200475
1.06	9.0	3	38	200219	200501
1.07	9.0	3	38	200179	200461
1.08	9.0	3	38	200180	200462
1.09	9.0	3	38	200216	200498
1.10	9.0	3	38	200194	200476
1.11	9.0	3	38	200164	200446
1.12	9.0	3	38	200183	200465
1.13	9.0	3	38	200212	200494
1.14	9.0	3	38	200220	200502
1.15	9.0	3	38	200195	200477
1.16	10.0	3	38	200166	200448
1.17	10.0	3	38	200163	200445
1.18	10.0	3	38	200177	200459
1.19	10.0	3	38	200217	200499
1.20	10.0	3	38	200196	200478
1.21	10.0	3	38	200165	200447
1.22	10.0	3	38	200181	200463
1.23	10.0	3	38	200161	200443
1.24	10.0	3	38	200221	200503
1.25	10.0	3	38	200197	200479
1.26	10.0	3	38	200206	200488
1.27	10.0	3	38	200203	200485
1.28	10.0	3	38	200218	200500
1.29	10.0	3	38	200222	200504
1.30	10.0	3	38	200153	200435
1.31	11.2	3	38	200188	200470
1.32	11.2	3	38	200176	200458
1.33	11.2	3	38	200162	200444
1.34	11.2	3	38	200202	200484
1.35	11.2	3	38	200198	200480
1.36	11.2	3	38	200205	200487
1.37	11.2	3	38	200158	200440
1.38	11.2	3	38	200223	200505
1.39	11.2	3	38	200224	200506
1.40	11.2	3	38	200154	200436
1.45	11.2	3	38	200199	200481
1.50	11.2	3	38	200200	200482
1.55	12.0	3	38	200170	200452
1.60	12.0	3	38	200171	200453
1.65	12.0	3	38	200172	200454
1.70	12.0	3	38	200155	200437
1.75	12.0	3	38	200173	200455
1.80	12.0	3	38	200159	200441
1.85	12.0	3	38	200174	200456
1.90	12.0	3	38	200156	200438
1.95	12.0	3	38	200175	200457
2.00	12.0	3	38	960037	200517
2.05	15.0	3	38	960038	200518
2.10	15.0	3	38	960039	200519
2.15	15.0	3	38	960040	200520
2.20	15.0	3	38	960041	200521
2.25	15.0	3	38	960042	200522
2.30	15.0	3	38	960043	200523
2.35	15.0	3	38	960044	200524
2.40	15.0	3	38	960045	200525
2.45	15.0	3	38	960046	200526
2.50	15.0	3	38	960047	200527
2.55	15.0	3	38	960048	200528
2.80	16.0	3	38	960049	200529



P. 71



P. 82

Acier + Pb	Acier faibl. allié	Acier fort. allié	Acier inox aust.	Fontes
Super alliages Ni / Co	Titane, alliage de titane	Alliage Cu Argent Or	Alliage Cu difficile	Alu

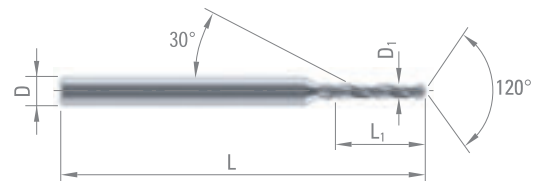

DIXI 1149 R TiAIN

FORETS HÉLICOÏDAUX AUTO-CENTRANTS
CORPS RENFORCÉ

Z = 2



P. 71



P. 86

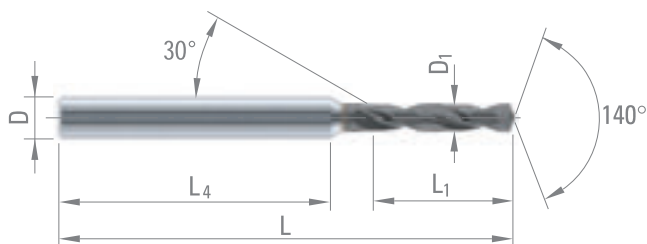

Acier + Pb	Acier faibl. allié	Acier fort. allié	Acier inox aust.	Fontes
Super alliages Ni / Co	Titane, alliage de titane	Alliage Cu difficile	Alu	

D ₁ h6	L ₁	L ₄	D _{h5}	L	TiAIN
1.00	5	26	3	38	976857
1.10	5	26	3	38	976858
1.20	5	26	3	38	976859
1.30	5	26	3	38	976860
1.40	5	26	3	38	976861
1.50	7	25	3	38	976862
1.60	7	25	3	38	976863
1.70	7	25	3	38	976864
1.80	7	25	3	38	976865
1.90	7	25	3	38	976866
2.00	9	35	3	50	43300
2.10	9	35	3	50	43301
2.20	9	35	3	50	43302
2.30	9	35	3	50	43303
2.40	9	35	3	50	43304
2.50	9	36	3	50	43305
2.60	11	31	4	50	43306
2.70	11	31	4	50	43307
2.80	11	31	4	50	41777
2.90	11	31	4	50	43308
3.00	14	39	6	62	43309
3.10	14	39	6	62	43310
3.175	14	39	6	62	64419
3.20	14	39	6	62	43311
3.30	14	39	6	62	43312
3.40	14	39	6	62	43313
3.50	14	39	6	62	43314
3.60	14	39	6	62	43315
3.70	14	40	6	62	43316
3.80	17	40	6	66	43317
3.90	17	40	6	66	43318
4.00	17	40	6	66	43319
4.10	17	40	6	66	43320
4.20	17	40	6	66	43321
4.30	17	40	6	66	43322
4.40	17	40	6	66	43323
4.50	17	40	6	66	43324
4.60	17	40	6	66	43325
4.70	17	40	6	66	43326



DIXI 1149 R TiAIN

D_{1h6}	L_1	L_4	D_{h5}	L	TiAIN
4.762	20	37	6	66	43673
4.80	20	37	6	66	43327
4.90	20	38	6	66	43328
5.00	20	38	6	66	43329
5.10	20	38	6	66	966749
5.20	20	38	6	66	43330
5.30	20	38	6	66	43331
5.40	20	38	6	66	966750
5.50	20	38	6	66	43332
5.60	22	37	6	66	960752
5.70	22	37	6	66	966751
5.80	22	37	6	66	43333
5.90	22	37	6	66	966752
6.00	22	37	6	66	43334
6.20	24	43	8	79	43447
6.30	24	43	8	79	43538
6.35	24	43	8	79	44585
6.40	24	43	8	79	63641
6.50	24	43	8	79	39394
6.60	24	43	8	79	43539
6.70	24	43	8	79	966756
6.80	24	44	8	79	43540
6.90	24	44	8	79	966757
7.00	29	43	8	79	43541
7.20	29	38	8	79	56826
7.50	29	38	8	79	43542
7.80	29	38	8	79	43543
8.00	29	39	8	79	43544
8.20	35	40	10	89	43448
8.40	35	40	10	89	55450
8.50	35	40	10	89	42654
8.70	35	41	10	89	54604
8.80	35	41	10	89	56828
9.00	35	41	10	89	43545
9.20	35	41	10	89	55451
9.50	35	41	10	89	43546
9.80	35	41	10	89	43547
10.00	35	42	10	89	43548
10.10	40	47	12	102	978563
10.20	40	47	12	102	43549
10.50	40	47	12	102	43550
10.80	40	48	12	102	59472
11.00	40	48	12	102	43551
11.50	41	47	12	102	43552
12.00	42	47	12	102	43553
13.00	46	47	14	107	43554
14.00	49	45	14	107	43556



P. 71



P. 86



Acier + Pb	Acier faibl. allié	Acier fort. allié	Acier inox aust.	Fontes
Super alliages Ni / Co	Titane, alliage de titane	Alliage Cu difficile	Alu	

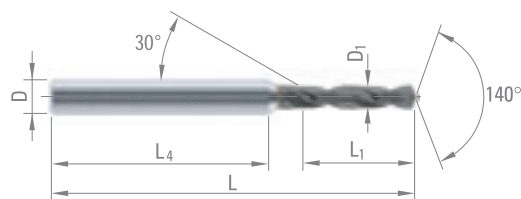

DIXI 1147 R TiAIN

FORETS HÉLICOÏDAUX AUTO-CENTRANTS
CORPS RENFORCÉ

Z = 2



P. 71



P. 88

$$L_1 = 6.5 \times D_1$$

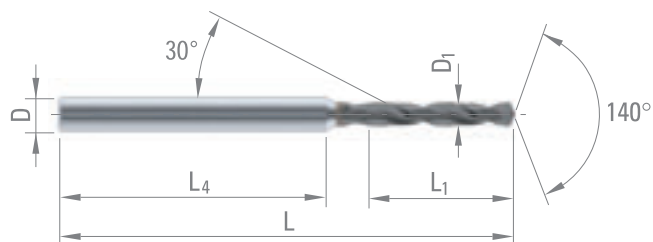

Acier + Pb	Acier faibl. allié	Acier fort. allié	Acier inox aust.	Fontes
Super alliages Ni / Co	Titane, alliage de titane	Alu		

D ₁ h6	L ₁	L ₄	D _{h5}	L	TiAIN
0.50	3.3	29	3	38	960468
0.55	3.6	29	3	38	960469
0.60	3.9	29	3	38	960470
0.65	4.2	33	3	43	960471
0.70	4.6	33	3	43	960472
0.75	4.9	33	3	43	960473
0.80	5.2	32	3	43	960474
0.85	5.5	32	3	43	960475
0.90	5.9	32	3	43	960476
0.95	6.2	32	3	43	960477
1.00	6.5	31	3	43	960478
1.10	7.2	31	3	43	960479
1.20	7.8	37	3	50	960480
1.30	8.5	37	3	50	960481
1.40	9.1	36	3	50	960482
1.50	9.8	35	3	50	960483
1.60	10.4	35	3	50	960484
1.70	11.1	34	3	50	960485
1.80	11.7	34	3	50	960486
1.90	12.4	33	3	50	960487
2.00	13.0	43	4	62	960137
2.10	13.7	42	4	62	960138
2.20	14.3	42	4	62	960139
2.30	15.0	41	4	62	960140
2.40	15.6	41	4	62	960141
2.50	16.3	40	4	62	960142
2.60	16.9	39	4	62	960143
2.70	17.6	39	4	62	960144
2.80	18.2	38	4	62	960145
2.90	18.9	38	4	62	960146
3.00	19.5	37	4	62	960147
3.10	20.2	53	6	79	960148
3.20	20.8	52	6	79	960149
3.30	21.5	51	6	79	960150
3.40	22.1	51	6	79	960151
3.50	22.8	50	6	79	960152
3.60	23.4	50	6	79	966741
3.75	24.4	49	6	79	960153
3.80	24.7	48	6	79	960154
3.90	25.4	47	6	79	961304



DIXI 1147 R TiAIN

D_{1h6}	L_1	L_4	D_{h5}	L	TiAIN
4.00	26.0	47	6	79	960155
4.10	26.7	46	6	79	960156
4.20	27.3	45	6	79	960157
4.30	28.0	45	6	79	960158
4.40	28.6	44	6	79	959769
4.50	29.3	43	6	79	960159
4.60	29.9	43	6	79	960160
4.70	30.6	42	6	79	960161
4.80	31.2	42	6	79	960162
4.90	31.9	41	6	79	960163
5.00	32.5	50	6	89	959770
5.10	33.2	49	6	89	960167
5.20	33.8	49	6	89	960169
5.30	33.5	48	6	89	960170
5.40	35.1	48	6	89	966742
5.50	35.8	47	6	89	960171
5.60	36.4	46	6	89	960172
5.70	37.1	46	6	89	966743
5.80	37.7	45	6	89	960173
5.90	38.4	44	6	89	966744
6.00	39.0	44	6	89	960174
6.10	39.7	54	8	102	960175
6.20	40.3	53	8	102	960176
6.30	41.0	53	8	102	960177
6.35	41.3	53	8	102	960178
6.40	41.6	52	8	102	966745
6.50	42.3	51	8	102	960179
6.60	42.9	51	8	102	960180
6.70	43.6	50	8	102	966747
6.80	44.2	50	8	102	960181
6.90	44.9	49	8	102	966748
7.00	45.5	48	8	102	960182
7.20	46.8	47	8	102	960183
7.50	48.8	45	8	102	960184
7.80	50.7	43	8	102	960185
8.00	52.0	42	8	102	960186
8.20	53.3	54	10	118	960187
8.40	54.0	54	10	118	960188
8.50	55.3	52	10	118	960189
8.80	57.2	51	10	118	960190
9.00	58.5	49	10	118	960191
9.50	61.8	46	10	118	960192
9.80	63.7	44	10	118	960193
10.00	65.0	43	10	118	960194



P. 71



P. 88

Acier + Pb	Acier faibl. allié	Acier fort. allié	Acier inox aust.	Fontes
Super alliages Ni / Co	Titane, alliage de titane	Alu		

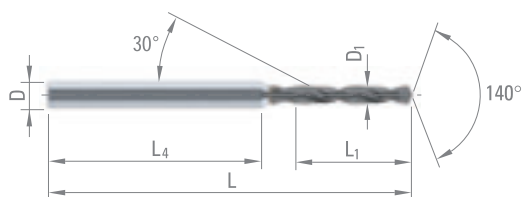

DIXI 1145 R TiAlN

FORETS AUTO-CENTRANTS
À TROUS DE LUBRIFICATION

Z = 2



P. 71



P. 86

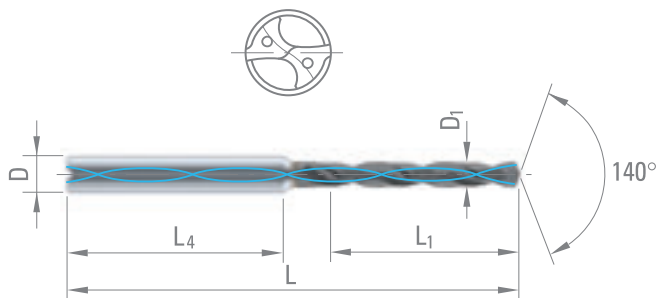

$D_{1\ h6}$	L_1	L_4	D_{h5}	L	TiAlN
0.70	5	26	3	38	956705
0.80	5	26	3	38	954321
0.90	5	27	3	38	956702
1.00	7	24	3	38	956701
1.10	7	24	3	38	956700
1.20	7	24	3	38	956699
1.30	7	24	3	38	956698
1.40	7	25	3	38	956694
1.50	11	20	3	38	956692
1.60	11	20	3	38	956690
1.70	11	20	3	38	956688
1.80	11	20	3	38	956686
1.90	11	20	3	38	956683
2.00	15	18	3	38	954320
2.10	15	18	3	38	956325
2.20	15	18	3	38	956326
2.30	15	26	4	50	956327
2.40	15	27	4	50	956328
2.50	18	24	4	50	956329
2.60	18	24	4	50	956330
2.70	18	24	4	50	956331
2.80	18	24	4	50	956332
2.90	23	35	6	66	956333
3.00	23	35	6	66	65470
3.10	23	35	6	66	953836
3.20	23	35	6	66	953835
3.30	23	35	6	66	65471
3.40	23	35	6	66	953837
3.50	23	35	6	66	65472
3.60	29	35	6	74	966718
3.70	29	35	6	74	966719
3.75	29	36	6	74	65473
3.80	29	36	6	74	953838
3.90	29	36	6	74	966720
4.00	29	36	6	74	45540
4.10	29	36	6	74	953839
4.20	29	36	6	74	56829
4.30	29	36	6	74	62995
4.40	29	36	6	74	956579
4.50	35	38	6	82	953840
4.60	35	38	6	82	966721
4.70	35	38	6	82	966722
4.80	35	38	6	82	45541
4.90	35	38	6	82	966826

Acier + Pb	Acier faibl. allié	Acier fort. allié	Acier inox aust.	Fontes
Super alliages Ni / Co	Titane, alliage de titane	Alliage Cu difficile	Alu	



DIXI 1145 R TiAIN

D _{1 h6}	L ₁	L ₄	D _{h5}	L	TiAIN
5.00	35	39	6	82	43272
5.10	35	39	6	82	953841
5.20	35	39	6	82	56830
5.30	35	39	6	82	59465
5.40	35	39	6	82	953842
5.50	35	39	6	82	45542
5.60	35	39	6	82	954509
5.70	35	39	6	82	966723
5.80	35	39	6	82	59466
5.90	35	39	6	82	966724
6.00	35	40	6	82	38821
6.10	43	36	8	91	953843
6.20	43	36	8	91	56831
6.30	43	36	8	91	43279
6.35	43	36	8	91	59467
6.40	43	36	8	91	953844
6.50	43	36	8	91	39758
6.60	43	36	8	91	59468
6.70	43	36	8	91	956886
6.80	43	36	8	91	45614
6.90	43	36	8	91	966725
7.00	43	36	8	91	43283
7.20	43	36	8	91	56833
7.30	43	36	8	91	954510
7.40	43	36	8	91	59384
7.50	43	36	8	91	43284
7.60	43	36	8	91	954511
7.80	43	36	8	91	43285
8.00	43	-	8	91	39530
8.10	49	40	10	103	954512
8.20	49	40	10	103	56834
8.30	49	40	10	103	954513
8.40	49	40	10	103	59469
8.50	49	40	10	103	52633
8.60	49	40	10	103	954514
8.80	49	40	10	103	45615
9.00	49	41	10	103	43288
9.20	49	41	10	103	953849
9.40	49	41	10	103	954515
9.50	49	41	10	103	63430
9.60	49	41	10	103	954516
9.70	49	41	10	103	953846
9.80	49	41	10	103	44777
10.00	49	-	10	103	40751
10.10	56	47	12	118	954326
10.20	56	47	12	118	56837
10.30	56	47	12	118	954518
10.50	56	47	12	118	44152
10.60	56	47	12	118	954517
10.80	56	47	12	118	45616
11.00	56	48	12	118	43294
11.30	58	46	12	118	954519
11.50	58	46	12	118	45207
12.00	60	45	12	118	40752
13.00	65	45	14	124	44339
14.00	70	-	14	124	45649



P. 71



P. 86



Acier + Pb	Acier faibl. allié	Acier fort. allié	Acier inox aust.	Fontes
Super alliages Ni / Co	Titane, alliage de titane	Alliage Cu difficile	Alu	

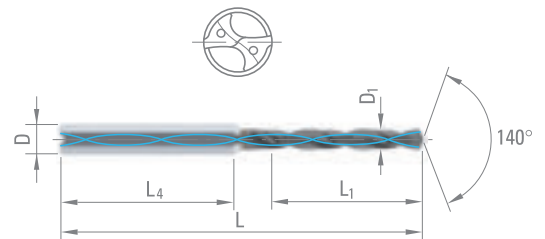

DIXI 1146 R TiAlN

FORETS AUTO-CENTRANTS
À TROUS DE LUBRIFICATION

Z = 2



P. 71



P. 88



$$L_1 = 10 \times D_1$$

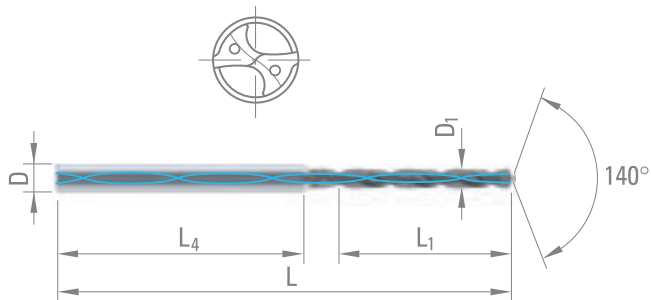

Acier + Pb	Acier faibl. allié	Acier fort. allié	Acier inox aust.	Fontes
Super alliages Ni / Co	Titane, alliage de titane	Alu		

D _{1 h6}	L ₁	L ₄	D _{h5}	L	TiAlN
0.80	8.0	37	3	50	960206
0.85	9.0	37	3	50	960208
0.90	9.0	36	3	50	960209
0.95	10.0	36	3	50	960210
1.00	10.0	35	3	50	960211
1.10	11.0	34	3	50	960212
1.20	12.0	33	3	50	960214
1.30	13.0	33	3	50	960215
1.40	14.0	32	3	50	960216
1.50	15.0	43	3	50	960217
1.60	16.0	42	3	62	960218
1.70	17.0	41	3	62	960219
1.80	18.0	40	3	62	960220
1.90	19.0	39	3	62	960221
2.00	20.0	38	3	62	960222
2.10	21.0	37	3	62	960223
2.20	22.0	36	3	62	960224
2.30	23.0	51	4	79	960225
2.40	24.0	50	4	79	960226
2.50	25.0	49	4	79	960227
2.60	26.0	48	4	79	960228
2.70	27.0	47	4	79	960229
2.80	28.0	46	4	79	960230
2.90	29.0	44	6	79	960231
3.00	30.0	43	6	79	960232
3.10	31.0	52	6	89	966726
3.20	32.0	51	6	89	966727
3.30	33.0	50	6	89	960243
3.40	34.0	49	6	89	966728
3.50	35.0	48	6	89	960244
3.60	36.0	47	6	89	966729
3.75	37.5	46	6	89	960245
3.90	39.0	44	6	89	966730
4.00	40.0	56	6	102	960246
4.10	41.0	55	6	102	966731
4.20	42.0	54	6	102	960247
4.30	43.0	53	6	102	960248
4.40	44.0	52	6	102	966732
4.50	45.0	51	6	102	960249



DIXI 1146 R TiAIN

$D_{1\ h6}$	L_1	L_4	D_{h5}	L	TiAIN
4.60	46.0	50	6	102	966733
4.70	47.0	49	6	102	966734
4.80	48.0	48	6	102	960250
4.90	49.0	47	6	102	966735
5.00	50.0	46	6	102	960251
5.10	51.0	45	6	102	966736
5.20	52.0	44	6	102	960252
5.30	53.0	43	6	102	960253
5.40	54.0	42	6	102	966737
5.50	55.0	41	6	102	960254
5.60	56.0	56	6	118	966738
5.70	57.0	55	6	118	966739
5.80	58.0	54	6	118	960255
5.90	59.0	53	6	118	963660
6.00	60.0	52	6	118	960256
6.10	61.0	49	8	118	966740
6.20	62.0	48	8	118	960257
6.30	63.0	47	8	118	960426
6.35	63.5	47	8	118	960427
6.50	65.0	45	8	118	960428
6.60	66.0	59	8	133	960429
6.80	68.0	57	8	133	960430
6.90	69.0	56	8	133	963661
7.00	70.0	55	8	133	960431
7.20	72.0	53	8	133	960432
7.50	75.0	50	8	133	960433
7.80	78.0	47	8	133	960434
8.00	80.0	45	8	133	960435
8.20	82.0	59	10	151	960436
8.40	84.0	57	10	151	960437
8.50	85.0	56	10	151	960438
8.80	88.0	53	10	151	960439
9.00	90.0	60	10	160	960440
9.20	92.0	58	10	160	960441
9.40	94.0	56	10	160	960442
9.525	95.3	55	10	160	960443
9.80	98.0	52	10	160	960444
10.00	100.0	50	10	160	960445



P. 71



P. 88



Acier + Pb	Acier faibl. allié	Acier fort. allié	Acier inox aust.	Fontes
Super alliages Ni / Co	Titane, alliage de titane	Alu		

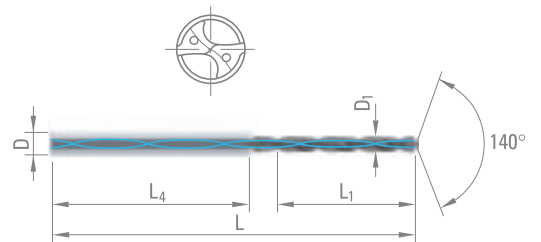

DIXI 1280 R XIDUR

FORETS HÉLICOÏDAUX POUR ACIERS DURS
CORPS RENFORCÉ

Z = 2



P. 71



P. 90



$\emptyset 0.25 < \emptyset 2.50$

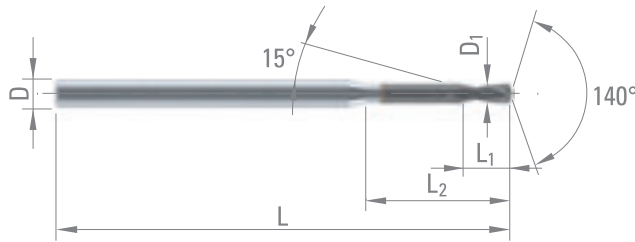

$\emptyset 2.50 \leq \emptyset 12.00$

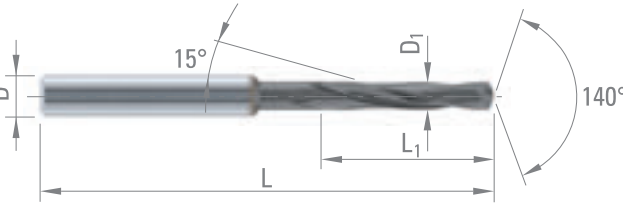

D_{1h6}	L_1	L_2	D_{h5}	L	XIDUR
0.25	0.75	2.0	3	38	957466
0.30	0.90	2.5	3	38	956658
0.40	1.20	3.2	3	38	956659
0.50	1.50	4.0	3	38	956660
0.60	1.80	4.8	3	38	956661
0.70	2.10	5.6	3	38	956662
0.80	2.40	6.5	3	38	956663
0.90	2.70	7.5	3	38	956664
1.00	3.00	8.0	3	38	956665
1.10	3.30	8.0	3	50	957524
1.20	3.60	10.0	3	50	956666
1.30	3.90	12.0	3	50	957525
1.40	4.20	12.0	3	50	957467
1.50	4.50	12.0	3	50	956667
1.60	4.80	15.0	3	50	957526
1.70	5.10	15.0	3	50	957527
1.80	5.40	15.0	3	50	956668
1.90	5.80	15.0	3	50	957528
2.00	6.00	16.0	3	50	956669

D_{1h6}	L_1	D_{h5}	L	XIDUR
2.50	15	3	62	62529
2.60	15	3	62	62843
2.70	15	3	62	62844
2.80	15	3	62	62845
2.90	15	3	62	62846
3.00	20	4	66	62530
3.10	20	4	66	62847
3.175	20	4	66	62848
3.30	20	4	66	62849
3.40	20	4	66	62850
3.50	20	4	66	62531
3.57	20	4	66	62851
3.70	20	4	66	62852
3.80	20	4	66	62853
3.90	20	4	66	62854
4.00	30	6	66	62532
4.10	30	6	66	62855
4.20	30	6	66	62533
4.30	30	6	66	62857
4.365	30	6	66	62858
4.50	30	6	66	62859

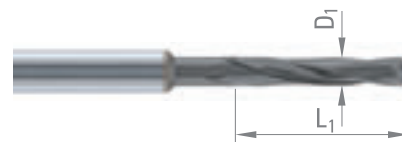
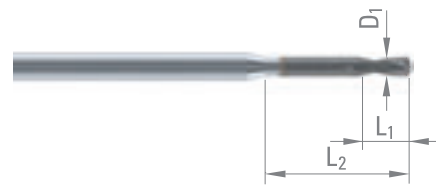

DIXI 1280 R XIDUR

D_{1h6}	L_1	D_{h5}	L	XIDUR
4.60	30	6	66	62860
4.70	30	6	66	62861
4.762	30	6	66	62862
4.90	30	6	66	62863
5.00	30	6	66	62534
5.10	30	6	66	62414
5.16	30	6	66	62864
5.50	30	6	66	62867
5.80	30	6	66	62870
6.00	40	8	79	62872
6.35	40	8	79	62874
6.50	40	8	79	62877
6.80	40	8	79	62535
7.00	40	8	79	62878
7.50	40	8	79	62880
7.80	40	8	79	62881
8.00	50	10	89	62882
8.33	50	10	89	62883
8.50	50	10	89	62536
8.73	50	10	89	62884
9.00	50	10	89	62885
9.525	50	10	89	62886
9.80	50	10	89	62887
10.00	60	12	102	62888
10.20	60	12	102	62889
10.50	60	12	102	62890
10.80	60	12	102	62891
11.00	60	12	102	62895
11.50	60	12	102	62896
12.00	60	12	102	62897



P. 71



P. 90



Acier
fort.
allié

Aciers
Fontes
45-65 HRC

Super
alliages
Ni / Co

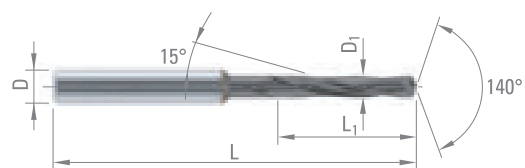

DIXI 1151 R

FORETS ALÉSEURS

Z = 3



P. 71



P. 90

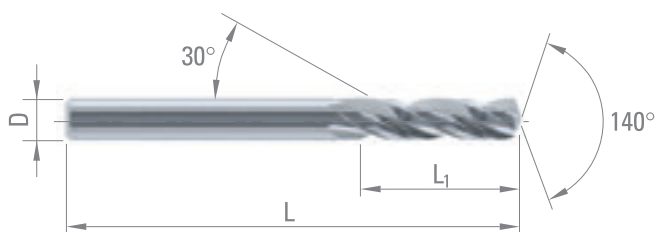

Acier + Pb

Acier faibl. allié

Fontes

Titane, alliage de titane

Alliage Cu Argent Or

Alu

D _{h5}	L ₁	L	CARBURE
1.00	8	30	31446
1.05	8	30	47890
1.10	10	30	31573
1.15	10	30	37288
1.20	10	30	31574
1.25	10	30	34553
1.30	10	30	31575
1.35	10	30	37506
1.40	10	30	31576
1.45	10	30	47039
1.50	10	30	31560
1.55	12	38	47891
1.60	12	38	31577
1.62	12	38	64852
1.63	12	38	41603
1.64	12	38	58867
1.65	12	38	38467
1.70	12	38	31578
1.75	12	38	43738
1.80	12	38	31579
1.85	12	38	47899
1.90	12	38	31294
1.95	12	38	47040
2.00	12	38	31580
2.04	12	38	954146
2.10	12	38	31581
2.20	13	40	41993
2.30	13	40	31583
2.40	14	43	39320
2.50	14	43	41454
2.60	14	43	42140
2.70	16	46	31295
2.80	16	46	31296
2.90	16	46	31586
3.00	16	46	29106
3.10	18	49	31197
3.20	18	49	31728
3.30	18	49	29107
3.40	20	52	33271
3.50	20	52	29108



DIXI 1151 R

D_{h5}	L_1	L	CARBURE
3.60	20	52	31297
3.70	20	52	32311
3.80	22	55	29109
3.90	22	55	42942
4.00	22	55	42305
4.10	22	55	42939
4.20	22	55	29111
4.30	24	58	32871
4.40	24	58	33427
4.50	24	58	29112
4.60	24	58	32862
4.70	24	58	32312
4.80	26	62	29113
4.90	26	62	31590
5.00	26	62	29114
5.10	26	62	41455
5.20	26	62	32639
5.30	26	62	31717
5.40	28	66	34791
5.50	28	66	29115
5.60	28	66	41597
5.70	28	66	32313
5.80	28	66	43809
5.90	28	66	45905
6.00	28	66	41120
6.10	31	70	41620
6.20	31	70	32640
6.30	31	70	34792
6.40	31	70	33105
6.50	31	70	29118
6.60	31	70	34754
6.70	31	70	31506
6.80	34	74	29119
6.90	34	74	32860
7.00	34	74	29120
7.50	34	74	29121
7.80	37	79	29122
8.00	37	79	43769
8.20	37	79	32237
8.50	37	79	41927
8.80	40	84	29125
9.00	40	84	29126
9.50	40	84	29127
9.80	43	89	29128
10.00	43	89	29129
10.20	43	89	29130
10.50	43	89	29131
11.00	47	95	29132
11.50	47	95	29133
12.00	51	102	29134
12.50	51	102	32641
13.00	51	102	29135
13.50	54	107	32642
14.00	54	107	29136



P. 71



P. 90

Acier
+ Pb

Acier
faibl.
allié

Fontes

Titane,
alliage de
titane

Alliage Cu
Argent
Or

Alu

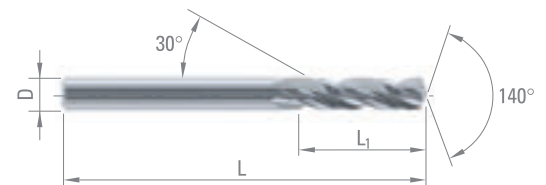

DIXI 1152 R

FORETS ALÉSEURS CORPS RENFORCÉ

Z = 3



P. 71



P. 90

$\emptyset 0.15 < \emptyset 0.50$

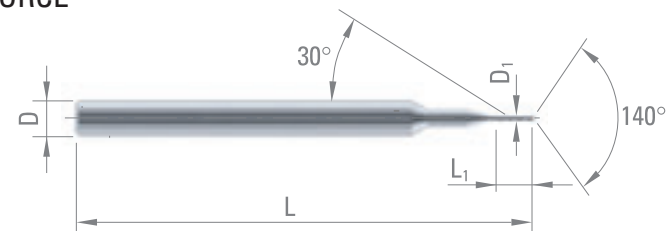

$\emptyset 0.50 \leq \emptyset 2.90$

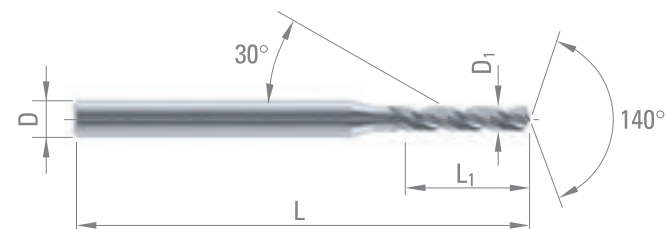

$D_{10/-0.004}$	L_1	D_2	L_2	D_{h5}	L	CARBURE
0.15	1.5	1.5	6.80	3.0	38	962817
0.20	1.5	1.5	6.80	3.0	38	962818
0.25	2.0	1.5	7.35	3.0	38	962819
0.30	2.0	1.5	7.35	3.0	38	962820
0.35	2.0	1.5	7.35	3.0	38	962821
0.40	2.0	1.5	7.35	3.0	38	962822
0.45	3.6	1.5	8.95	3.0	38	962850

$D_{10/-0.004}$	L_1	D_{h5}	L	CARBURE
0.50	4.0	3.0	38	962851
0.53	4.5	3.0	38	962852
0.55	4.5	3.0	38	962853
0.60	4.5	3.0	38	962854
0.62	5.0	3.0	38	962855
0.65	5.0	3.0	38	962856
0.70	5.6	3.0	38	962857
0.71	5.6	3.0	38	962858
0.75	5.6	3.0	38	962859
0.80	6.3	3.0	38	962860
0.81	6.3	3.0	38	962861
0.82	6.3	3.0	38	962862
0.83	6.3	3.0	38	962863
0.84	6.3	3.0	38	962864
0.85	6.3	3.0	38	962865
0.86	7.1	3.0	38	962866
0.87	7.1	3.0	38	962867
0.88	7.1	3.0	38	962868
0.89	7.1	3.0	38	962869
0.90	7.1	3.0	38	962870
0.91	7.1	3.0	38	962871
0.92	7.1	3.0	38	962872
0.93	7.1	3.0	38	962873
0.94	7.1	3.0	38	962874
0.95	7.1	3.0	38	962875
0.96	9.0	3.0	38	962876
0.97	9.0	3.0	38	962877
0.98	9.0	3.0	38	962878
0.99	9.0	3.0	38	962879
1.00	9.0	3.0	38	962880
1.01	9.0	3.0	38	962881
1.02	9.0	3.0	38	962882
1.03	9.0	3.0	38	962883
1.04	9.0	3.0	38	962884
1.05	9.0	3.0	38	962885
1.06	9.0	3.0	38	962886
1.07	9.0	3.0	38	962887

- Acier + Pb
- Acier faibl. allié
- Fontes
- Titane, alliage de titane
- Alliage Cu Argent Or
- Alu

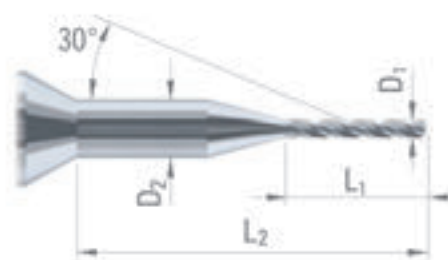

DIXI 1152 R

$D_{10/-0.004}$	L_1	D_{h5}	L	CARBURE
1.08	9.0	3.0	38	962888
1.09	9.0	3.0	38	962889
1.10	9.0	3.0	38	962890
1.11	9.0	3.0	38	962901
1.12	9.0	3.0	38	962902
1.13	9.0	3.0	38	962903
1.14	9.0	3.0	38	962904
1.15	9.0	3.0	38	962905
1.16	10.0	3.0	38	962906
1.17	10.0	3.0	38	962907
1.18	10.0	3.0	38	962908
1.19	10.0	3.0	38	962909
1.20	10.0	3.0	38	962910
1.21	10.0	3.0	38	962911
1.22	10.0	3.0	38	962912
1.23	10.0	3.0	38	962913
1.24	10.0	3.0	38	962914
1.25	10.0	3.0	38	962915
1.26	10.0	3.0	38	962916
1.27	10.0	3.0	38	962917
1.28	10.0	3.0	38	962918
1.29	10.0	3.0	38	962919
1.30	10.0	3.0	38	962920
1.31	11.2	3.0	38	962921
1.32	11.2	3.0	38	962922
1.33	11.2	3.0	38	962923
1.34	11.2	3.0	38	962925
1.35	11.2	3.0	38	962926
1.36	11.2	3.0	38	962927
1.37	11.2	3.0	38	962928
1.38	11.2	3.0	38	962930
1.39	11.2	3.0	38	962931
1.40	11.2	3.0	38	962932
1.45	11.2	3.0	38	962933
1.50	11.2	3.0	38	962934
1.55	12.0	3.0	38	962935
1.60	12.0	3.0	38	962936
1.65	12.0	3.0	38	962937
1.67	12.0	3.0	38	962959
1.70	12.0	3.0	38	962938
1.75	12.0	3.0	38	962940
1.80	12.0	3.0	38	962941
1.85	12.0	3.0	38	962942
1.90	12.0	3.0	38	962943
1.95	12.0	3.0	38	962944
2.00	12.0	3.0	38	962945
2.03	15.0	3.0	38	962960
2.04	15.0	3.0	38	962961
2.05	15.0	3.0	38	963109
2.10	15.0	3.0	38	963111
2.15	15.0	3.0	38	963115
2.20	15.0	3.0	38	963116
2.25	15.0	3.0	38	963117
2.30	15.0	3.0	38	963118
2.35	15.0	3.0	38	963119
2.40	15.0	3.0	38	963120
2.45	15.0	3.0	38	963121
2.50	15.0	3.0	38	963122
2.55	15.0	3.0	38	963123
2.60	15.0	3.0	38	963124
2.70	16.0	3.0	38	963125
2.80	16.0	3.0	38	963126
2.90	16.0	3.0	38	963127



P. 71



P. 90

Acier
+ Pb

Acier
faibl.
allié

Fontes

Titane,
alliage de
titane

Alliage Cu
Argent
Or

Alu

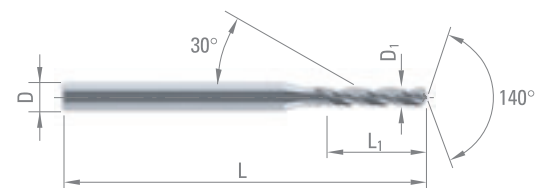

DIXI 1290 R

FORETS POUR MATIÈRES COMPOSITES /
KEVLAR®

Z = 2



Kevlar®

Conditions de coupe: $V_c = 100 - 150 \text{ m/min}$
 $f = 0.05 - 0.15 \text{ mm/tr}$

D _{h5}	inches	L ₁	L	CARBURE
2.50		18	50	29322
3.00		18	50	26766
3.175	1/8"	18	50	27059
3.20		18	50	27948
3.30		18	50	28660
3.50		20	50	27949
3.80		20	50	26283
3.968	5/32"	22	50	27950
4.00		22	50	26767
4.10		22	50	29224
4.20		25	55	27951
4.50		25	58	27731
4.80		25	62	29324
5.00		25	62	29299
5.20		25	62	29072
5.50		25	66	27952
5.556	7/32"	25	60	26588



D _{h5}	inches	L ₁	L	CARBURE
5.60		30	66	29215
6.00		30	66	43244
6.35	1/4"	30	70	27199
6.50		30	70	28661
8.00		35	75	26663
9.00		35	75	27957
9.525	3/8"	35	75	27959
10.00		35	75	27684
11.00		50	100	29493
12.00		50	100	26723
12.70	1/2"	50	100	26761



DIXI 1112 R+L

FORETS PLATS

Ø 0.08 - 5.99

Z = 2



P. 74

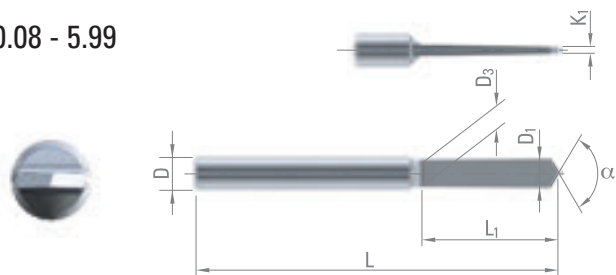

Acier + Pb	Fontes	Alliage Cu Argent Or	Alliage Cu difficile	Alu
Plastique				

DIXI 1114 R+L

MÈCHES À CANON DEMI-LUNE
EXÉCUTION A OU B

Ø 0.08 - 5.99

Z = 1

Valeurs indicatives pour définir les forets
DIXI 1112, 1114 et 1118.

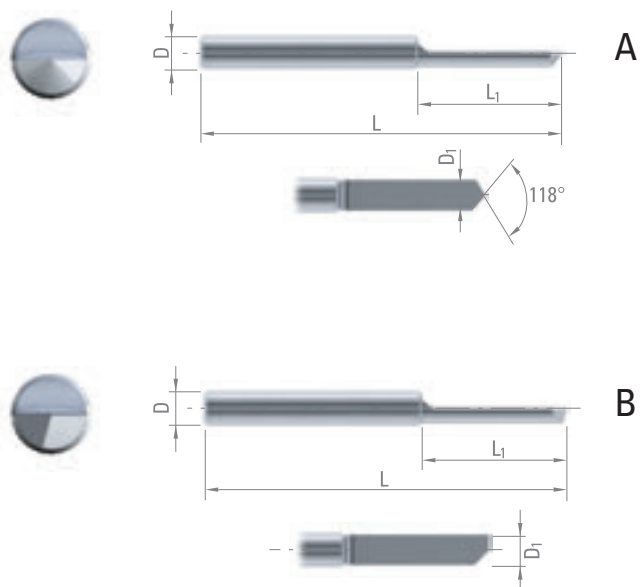

$D_{10/-0.004}$	L_1	D_{h5}	L
0.08 - 0.14	0.7	1.0	30
0.15 - 0.29	1.0	1.0	30
0.30 - 0.39	1.5	1.0	30
0.40 - 0.44	2.0	1.0	30
0.45 - 0.48	3.6	1.0	30
0.49 - 0.53	4.0	1.0	30
0.54 - 0.60	4.5	1.0	30
0.61 - 0.67	5.0	1.0	30
0.68 - 0.75	5.6	1.0	30
0.76 - 0.79	6.3	1.0	30
0.80 - 0.85	6.3	1.5	30
0.86 - 0.95	7.1	1.5	30
0.96 - 0.99	8.0	1.5	30
1.00 - 1.18	9.0	1.5	30
1.19 - 1.32	10.0	1.5	30
1.33 - 1.49	11.2	1.5	30
1.50 - 1.99	12.0	2.0	38
2.00 - 2.49	12.0	2.5	43
2.50 - 2.99	15.0	3.0	46
3.00 - 3.49	18.0	3.5	50
3.50 - 3.99	18.0	4.0	50
4.00 - 4.49	20.0	4.5	50
4.50 - 4.99	22.0	5.0	50
5.00 - 5.49	25.0	5.5	50
5.50 - 5.99	25.0	6.0	50

DIXI 1118 R+L

FORETS DENTURE DROITE

Ø 0.08 - 5.99

Z = 2

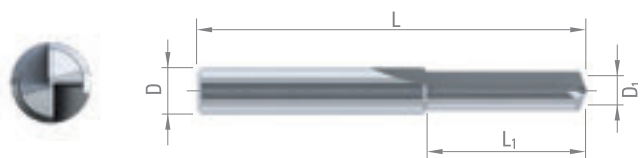



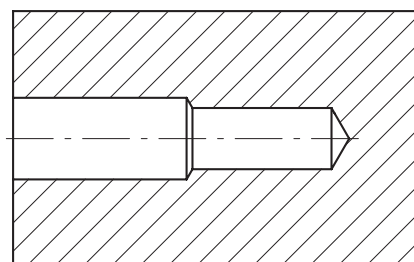

DIXI 1501 R L

Z =

Quantités

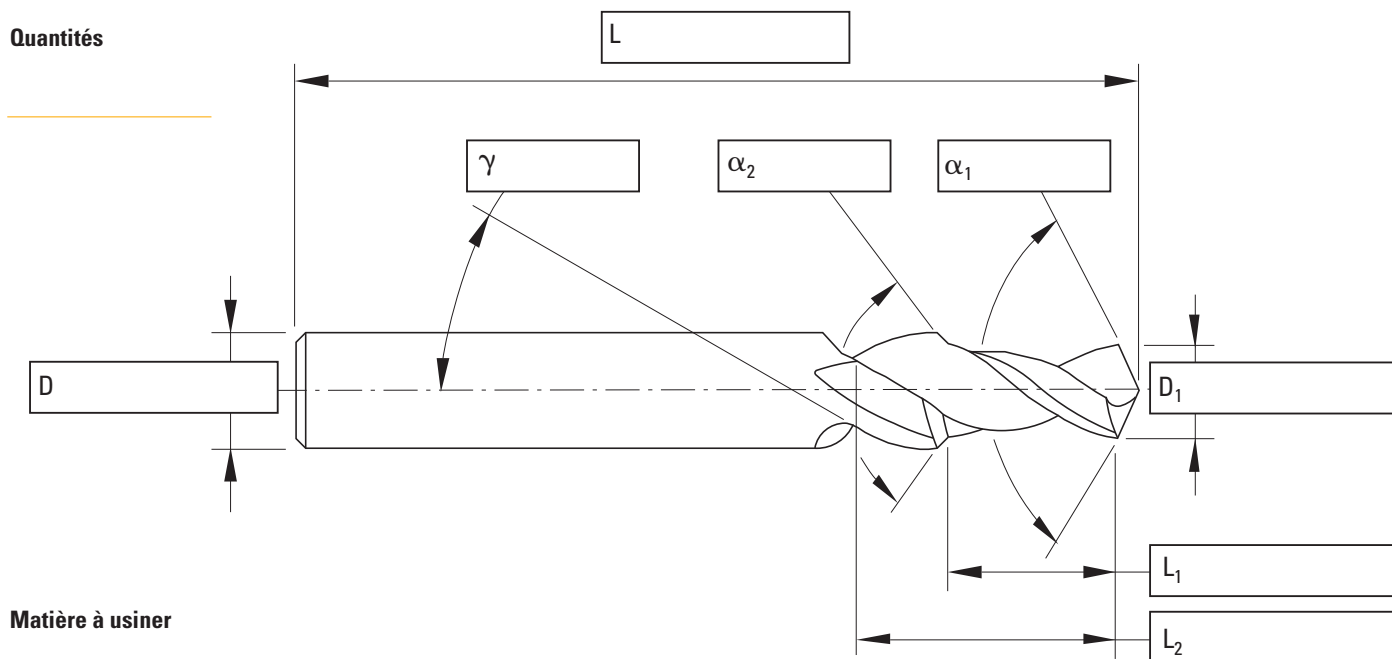

Matière à usiner

CONSULTEZ NOTRE FORMULAIRE DE DEMANDE D'OFFRES EN LIGNE SUR
WWW.DIXIPOLYTOOL.COM





DESSINS POUR COMMANDES
DE FORETS ÉTAGÉS



P. 92

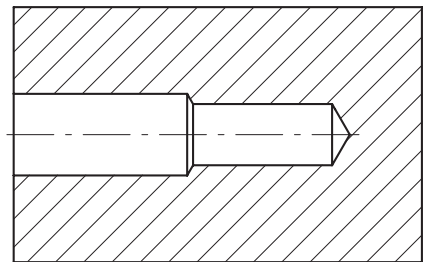

DIXI 1502 R L

Z =

Quantités

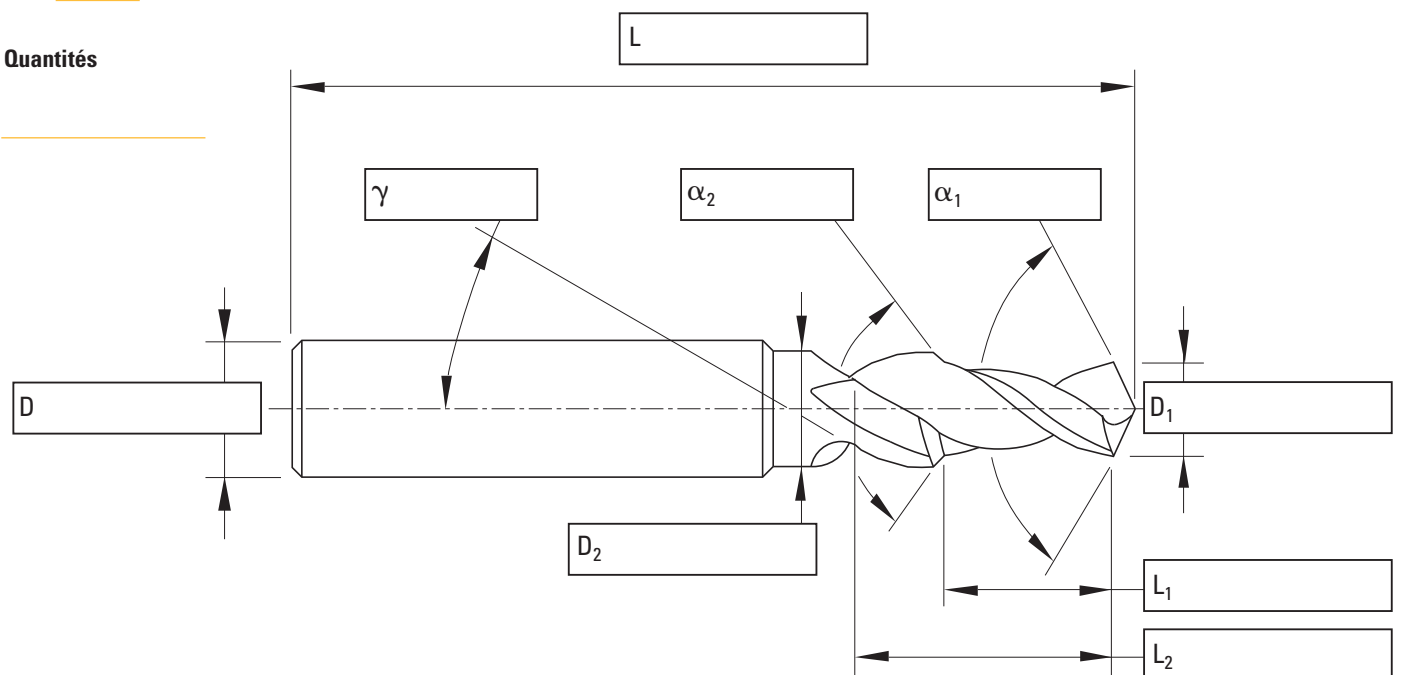

Matière à usiner

CONSULTEZ NOTRE FORMULAIRE DE DEMANDE D'OFFRES EN LIGNE SUR
WWW.DIXIPOLYTOOL.COM





DESSINS POUR COMMANDES
DE FORETS ÉTAGÉS



P. 92

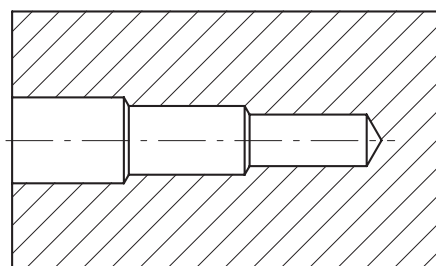

DIXI 1503 R L

Z =

Quantités

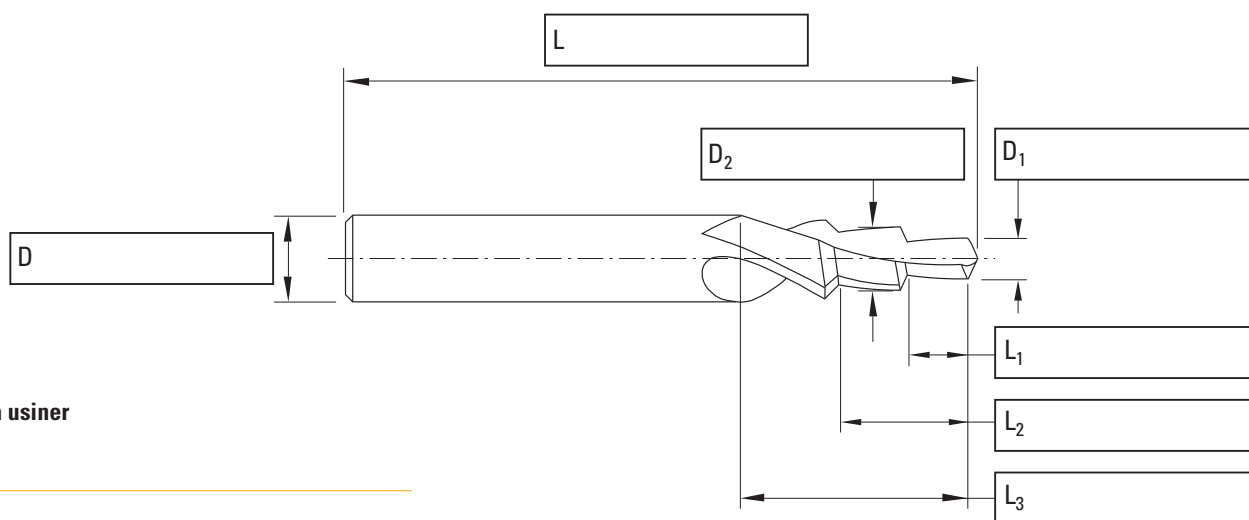
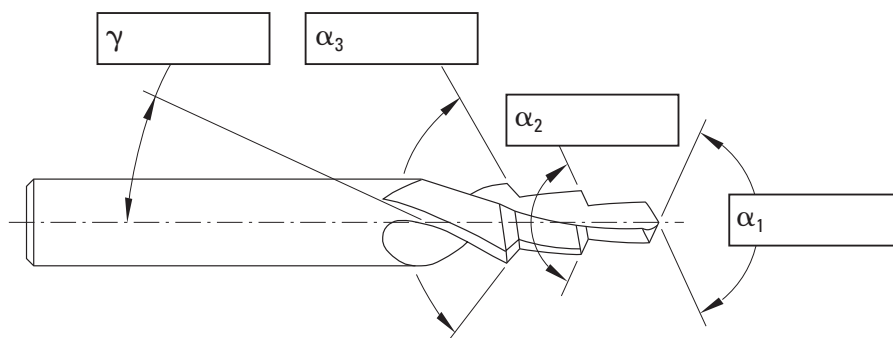

Matière à usiner

CONSULTEZ NOTRE FORMULAIRE DE DEMANDE D'OFFRES EN LIGNE SUR
WWW.DIXIPOLYTOOL.COM





DESSINS POUR COMMANDES DE FORETS ÉTAGÉS



P. 92

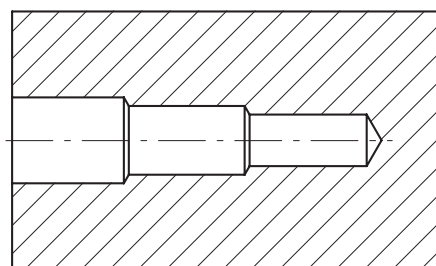

DIXI 1504 R L

Z =

Quantités

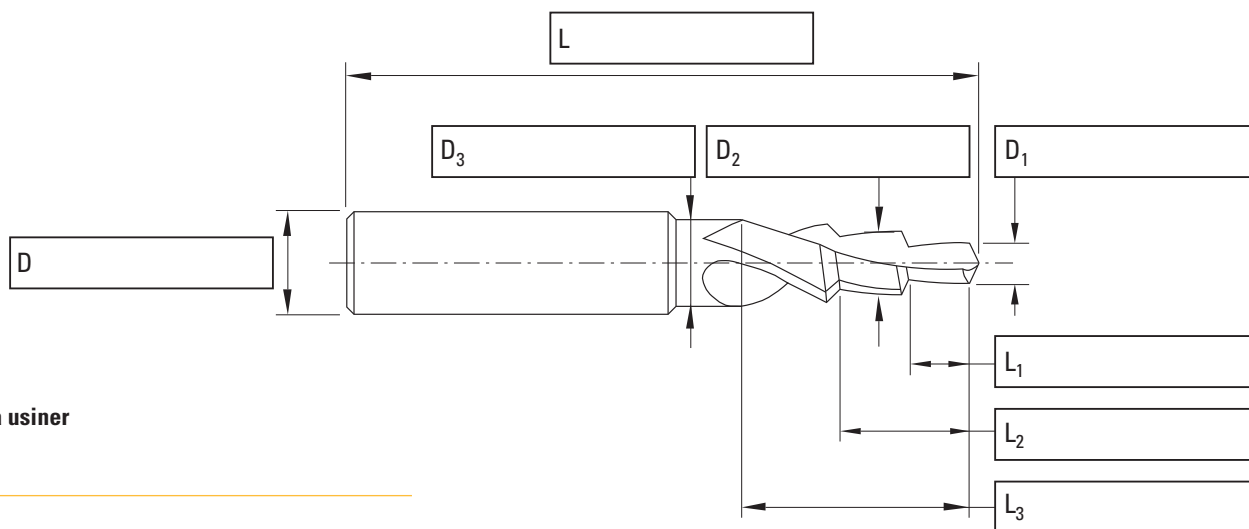
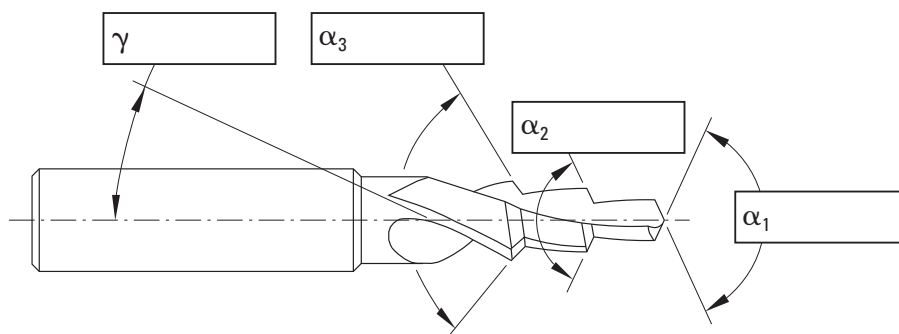

Matière à usiner

CONSULTEZ NOTRE FORMULAIRE DE DEMANDE D'OFFRES EN LIGNE SUR
WWW.DIXIPOLYTOOL.COM



GÉOMÉTRIE DES FORETS

Le foret hélicoïdal d'usage général est du type que nous illustrons ci-contre. Il peut être cylindrique ou avoir un corps renforcé.

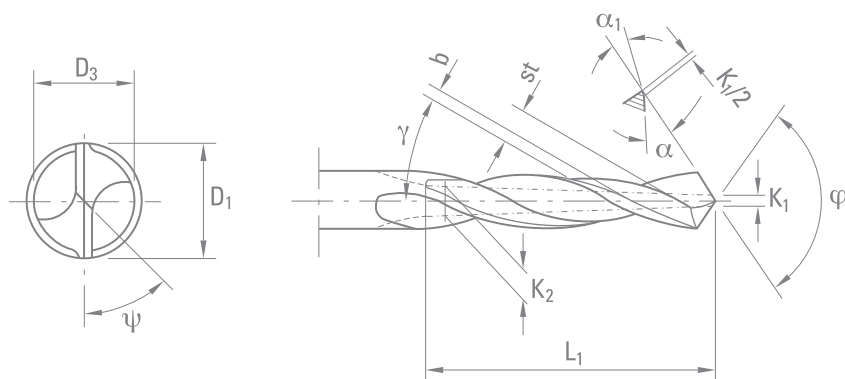

AMINCISSEMENT D'ÂME

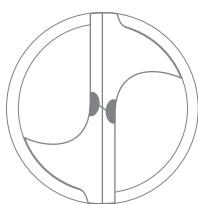

SOLUTION POUR LES PERÇAGES DIFFICILES

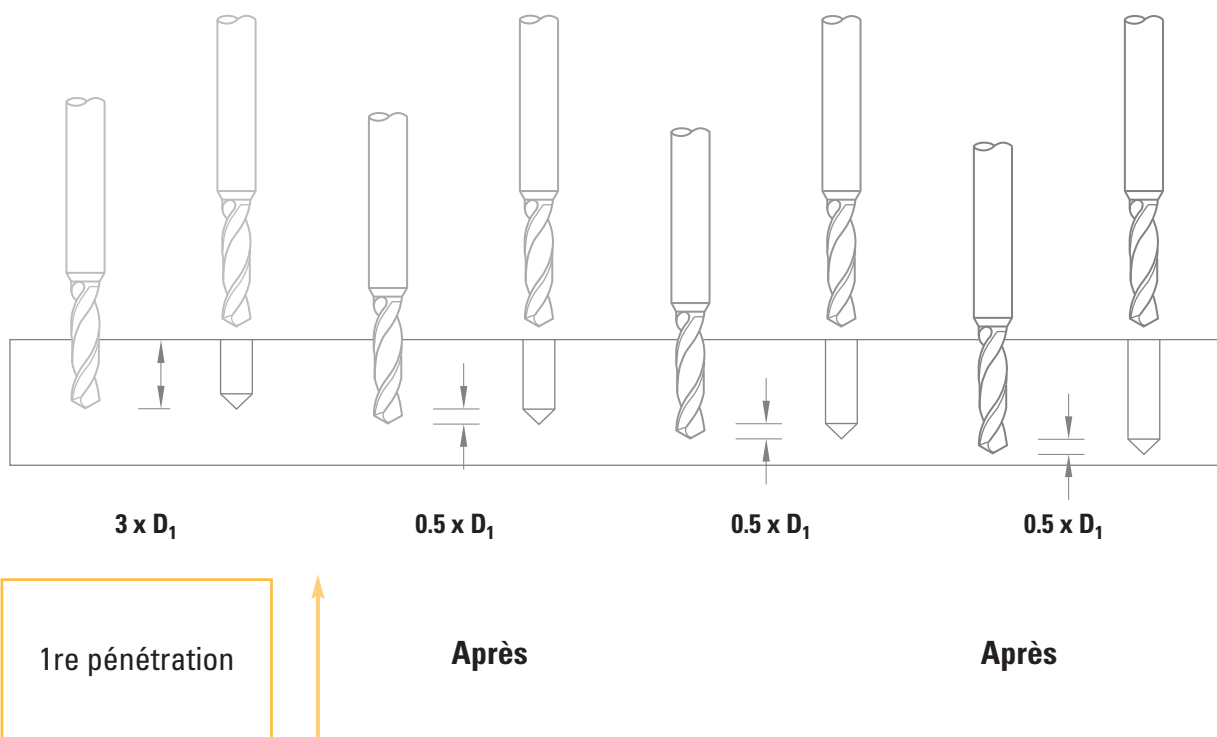

CONDITIONS DE COUPE

Matières à usiner			CARBURE		DICUT - TiAlN	
			Vc [m/min]		Vc [m/min]	
P	Acier non allié / faiblement allié	< 600 N/mm ²	40	60	50	70
P	Acier non allié / faiblement allié	600 – 1500 N/mm ²	30	50	40	60
P	Acier de décolletage au plomb		60	90		
P	Acier fortement allié	700 – 1500 N/mm ²	15	40	25	50
M	Acier inoxydable	400 – 700 N/mm ²	35	50	40	60
M	Acier inox. DUPLEX, acier austénitique inox. sans nickel	> 800 N/mm ²	20	40	30	50
K	Fonte grise / Fonte à graphite sphéroïdal perlitique	< 250 HB	30	50	40	60
K	Fonte alliée / Fonte à graphite sphéroïdal perlitique	> 250 HB	30	50	40	60
K	Fonte à graphite sphéroïdal ferritique / Fonte malléable		10	30	20	40
S	Super alliages / Acier inox. réfractaire	Inconel Nimonic Hastelloy	10	25	20	50
S	Titane, alliage de titane		80	100		
N	Alliage de cuivre / bonne usinabilité (laiton – bronze)		40	70	60	80
N	Alliage de cuivre / usinabilité difficile / Bronze à l'aluminium	(CuAlFe) (Ampco)	80	100	90	120
N	Alliage d'aluminium	Si < 8%	90	150	120	160
N	Fonte d'aluminium	Si > 8%	70	110	90	130
N	Plastique		30	60	50	80
N	Or, argent		50	80	65	100



$$n \text{ [tr/min]} = \frac{Vc \text{ [m/min]} \times 1000}{\pi \times D_1 \text{ [mm]}}$$

$$Vf \text{ [mm/min]} = n \text{ [tr/min]} \times f \text{ [mm]}$$

Avance par tour **f [mm]**

$\emptyset D_1$ 0.50 - 1.00	$\emptyset D_1$ 1.00 - 1.50	$\emptyset D_1$ 1.50 - 2.00	$\emptyset D_1$ 2.00 - 3.00	$\emptyset D_1$ 3.00 - 5.00	$\emptyset D_1$ 5.00 - 7.00	$\emptyset D_1$ 7.00 - 10.00	$\emptyset D_1$ 10.00 - 14.00	$\emptyset D_1$ 14.00 - 16.00	$\emptyset D_1$ 16.00 - 20.00
0.009 - 0.020	0.016 - 0.030	0.024 - 0.04	0.03 - 0.05	0.05 - 0.10	0.08 - 0.14	0.11 - 0.20	0.16 - 0.28	0.22 - 0.32	0.26 - 0.40
0.007 - 0.015	0.013 - 0.023	0.020 - 0.03	0.03 - 0.04	0.04 - 0.08	0.07 - 0.11	0.09 - 0.15	0.13 - 0.21	0.18 - 0.24	0.21 - 0.30
0.009 - 0.020	0.016 - 0.030	0.024 - 0.04	0.03 - 0.05	0.05 - 0.10	0.08 - 0.14	0.11 - 0.20	0.16 - 0.28	0.22 - 0.32	0.26 - 0.40
0.006 - 0.015	0.011 - 0.023	0.017 - 0.03	0.02 - 0.04	0.03 - 0.08	0.06 - 0.11	0.08 - 0.15	0.11 - 0.21	0.15 - 0.24	0.18 - 0.30
0.007 - 0.015	0.013 - 0.023	0.020 - 0.03	0.03 - 0.04	0.04 - 0.08	0.07 - 0.11	0.09 - 0.15	0.13 - 0.21	0.18 - 0.24	0.21 - 0.30
0.006 - 0.015	0.011 - 0.023	0.017 - 0.03	0.02 - 0.04	0.03 - 0.08	0.06 - 0.11	0.08 - 0.15	0.11 - 0.21	0.15 - 0.24	0.18 - 0.30
0.006 - 0.015	0.011 - 0.023	0.017 - 0.03	0.02 - 0.04	0.03 - 0.08	0.06 - 0.11	0.08 - 0.15	0.11 - 0.21	0.15 - 0.24	0.18 - 0.30
0.007 - 0.015	0.013 - 0.023	0.020 - 0.03	0.03 - 0.04	0.04 - 0.08	0.07 - 0.11	0.09 - 0.15	0.13 - 0.21	0.18 - 0.24	0.21 - 0.30
0.006 - 0.015	0.011 - 0.020	0.017 - 0.03	0.02 - 0.04	0.03 - 0.08	0.06 - 0.11	0.08 - 0.15	0.11 - 0.21	0.15 - 0.24	0.18 - 0.30
0.006 - 0.015	0.011 - 0.023	0.017 - 0.03	0.02 - 0.04	0.03 - 0.08	0.06 - 0.11	0.08 - 0.15	0.11 - 0.21	0.15 - 0.24	0.18 - 0.30
0.011 - 0.030	0.020 - 0.045	0.030 - 0.06	0.04 - 0.08	0.06 - 0.15	0.10 - 0.21	0.14 - 0.30	0.20 - 0.42	0.28 - 0.48	0.32 - 0.60
0.009 - 0.020	0.016 - 0.030	0.024 - 0.04	0.03 - 0.05	0.05 - 0.10	0.08 - 0.14	0.11 - 0.20	0.16 - 0.28	0.22 - 0.32	0.26 - 0.40
0.011 - 0.030	0.020 - 0.045	0.030 - 0.06	0.04 - 0.08	0.06 - 0.15	0.10 - 0.21	0.14 - 0.30	0.20 - 0.42	0.28 - 0.48	0.32 - 0.60
0.011 - 0.030	0.020 - 0.045	0.030 - 0.06	0.04 - 0.08	0.06 - 0.15	0.10 - 0.21	0.14 - 0.30	0.20 - 0.42	0.28 - 0.48	0.32 - 0.60
0.011 - 0.030	0.020 - 0.045	0.030 - 0.06	0.04 - 0.08	0.06 - 0.15	0.10 - 0.21	0.14 - 0.30	0.20 - 0.42	0.28 - 0.48	0.32 - 0.60
0.011 - 0.030	0.020 - 0.045	0.030 - 0.06	0.04 - 0.08	0.06 - 0.15	0.10 - 0.21	0.14 - 0.30	0.20 - 0.42	0.28 - 0.48	0.32 - 0.60
0.013 - 0.045	0.027 - 0.068	0.041 - 0.09	0.05 - 0.11	0.08 - 0.23	0.14 - 0.32	0.19 - 0.45	0.27 - 0.63	0.38 - 0.72	0.43 - 0.90
0.011 - 0.030	0.020 - 0.045	0.030 - 0.06	0.04 - 0.08	0.06 - 0.15	0.10 - 0.21	0.14 - 0.30	0.20 - 0.42	0.28 - 0.48	0.32 - 0.60



CONDITIONS DE COUPE

Matières à usiner

		CARBURE	
		Vc [m/min]	
P	Acier de décolletage au plomb	40	60
N	Alliage de cuivre / bonne usinabilité (laiton – bronze)	50	70
N	Alliage de cuivre / usinabilité difficile / Bronze à l'aluminium (CuAlFe) (Ampco)	30	50
N	Or, argent	30	60
N	Plastique	30	60

DIXI 1112 - 1118

		CARBURE	
		Vc [m/min]	
P	Acier non allié / faiblement allié < 600 N/mm ²	20	40
P	Acier de décolletage au plomb	40	60
K	Fonte à graphite sphéroïdal ferritique / Fonte malléable	20	40
N	Alliage de cuivre / bonne usinabilité (laiton – bronze)	50	80
N	Alliage de cuivre / usinabilité difficile / Bronze à l'aluminium (CuAlFe) (Ampco)	30	50
N	Alliage d'aluminium Si < 8%	60	100
N	Fonte d'aluminium Si > 8%	50	90
N	Plastique	30	60



$$n \text{ [tr/min]} = \frac{Vc \text{ [m/min]} \times 1000}{\pi \times D_1 \text{ [mm]}}$$

$$Vf \text{ [mm/min]} = n \text{ [tr/min]} \times f \text{ [mm]}$$

Avance par tour **f [mm]**

$\emptyset D_1$ 0.08 - 0.70	$\emptyset D_1$ 0.70 - 1.00	$\emptyset D_1$ 1.00 - 1.50	$\emptyset D_1$ 1.50 - 2.00	$\emptyset D_1$ 2.00 - 3.00	$\emptyset D_1$ 3.00 - 4.00	$\emptyset D_1$ 4.00 - 6.00
0.001 - 0.011	0.008 - 0.016	0.012 - 0.02	0.02 - 0.03	0.02 - 0.05	0.04 - 0.06	0.05 - 0.10
0.001 - 0.018	0.011 - 0.025	0.015 - 0.04	0.02 - 0.05	0.03 - 0.08	0.05 - 0.10	0.06 - 0.15
0.001 - 0.011	0.008 - 0.016	0.012 - 0.024	0.018 - 0.032	0.024 - 0.048	0.04 - 0.06	0.05 - 0.10
0.001 - 0.018	0.011 - 0.025	0.015 - 0.04	0.02 - 0.05	0.03 - 0.08	0.05 - 0.10	0.06 - 0.15
0.002 - 0.004	0.003 - 0.059	0.036 - 0.08	0.05 - 0.10	0.06 - 0.14	0.09 - 0.22	0.13 - 0.29

Avance par tour **f [mm]**

$\emptyset D_1$ 0.08 - 0.70	$\emptyset D_1$ 0.70 - 1.00	$\emptyset D_1$ 1.00 - 1.50	$\emptyset D_1$ 1.50 - 2.00	$\emptyset D_1$ 2.00 - 3.00	$\emptyset D_1$ 3.00 - 4.00	$\emptyset D_1$ 4.00 - 6.00
0.001 - 0.011	0.008 - 0.016	0.012 - 0.024	0.018 - 0.032	0.024 - 0.048	0.04 - 0.06	0.05 - 0.10
0.001 - 0.011	0.008 - 0.016	0.012 - 0.024	0.018 - 0.032	0.024 - 0.048	0.04 - 0.06	0.05 - 0.10
0.001 - 0.009	0.008 - 0.013	0.011 - 0.020	0.017 - 0.026	0.022 - 0.039	0.03 - 0.05	0.04 - 0.08
0.001 - 0.018	0.011 - 0.025	0.015 - 0.038	0.023 - 0.050	0.030 - 0.075	0.05 - 0.10	0.06 - 0.15
0.001 - 0.011	0.008 - 0.016	0.012 - 0.024	0.018 - 0.032	0.024 - 0.048	0.04 - 0.06	0.05 - 0.10
0.001 - 0.018	0.011 - 0.025	0.015 - 0.038	0.023 - 0.050	0.030 - 0.075	0.05 - 0.10	0.06 - 0.15
0.001 - 0.018	0.011 - 0.025	0.015 - 0.038	0.023 - 0.050	0.030 - 0.075	0.05 - 0.10	0.06 - 0.15
0.002 - 0.004	0.003 - 0.059	0.036 - 0.08	0.05 - 0.10	0.06 - 0.14	0.09 - 0.22	0.13 - 0.29

$D_1 < 1\text{mm} \Rightarrow Vc - 30\%$



CONDITIONS DE COUPE

Matières à usiner			CARBURE		DICUT	
			Vc [m/min]		Vc [m/min]	
P	Acier non allié / faiblement allié	< 600 N/mm ²	40	60	50	70
P	Acier non allié / faiblement allié	600 – 1500 N/mm ²			30	40
P	Acier de décolletage au plomb		70	100		
M	Acier inoxydable	400 – 700 N/mm ²			45	60
M	Acier inox. DUPLEX, acier austénitique inox. sans nickel	> 800 N/mm ²			30	50
K	Fonte grise / Fonte à graphite sphéroïdal perlitique	< 250 HB	50	80	60	90
K	Fonte à graphite sphéroïdal ferritique / Fonte malléable				40	60
S	Super alliages / Acier inox. réfractaire	Inconel Nimonic Hastelloy			20	40
S	Titane, alliage de titane		30	50		
N	Alliage de cuivre / bonne usinabilité (laiton – bronze)		80	100		
N	Alliage de cuivre / usinabilité difficile / Bronze à l'aluminium	(CuAlFe) (Ampco)	40	70	50	80
N	Alliage d'aluminium	Si < 8%	90	110	120	130
N	Fonte d'aluminium	Si > 8%	70	110	90	130
N	Plastique		30	60		
N	Or, argent		50	80		



$$n \text{ [tr/min]} = \frac{Vc \text{ [m/min]} \times 1000}{\pi \times D_1 \text{ [mm]}}$$

$$Vf \text{ [mm/min]} = n \text{ [tr/min]} \times f \text{ [mm]}$$

Avance par tour **f [mm]**

$\emptyset D_1$ 1.00 - 1.50	$\emptyset D_1$ 1.50 - 2.00	$\emptyset D_1$ 2.00 - 3.00	$\emptyset D_1$ 3.00 - 4.00	$\emptyset D_1$ 4.00 - 5.00	$\emptyset D_1$ 5.00 - 6.00	$\emptyset D_1$ 6.00 - 8.00	$\emptyset D_1$ 8.00 - 10.00	$\emptyset D_1$ 10.00 - 12.00	$\emptyset D_1$ 12.00 - 14.00
0.014 - 0.032	0.027 - 0.041	0.034 - 0.06	0.05 - 0.08	0.06 - 0.09	0.07 - 0.11	0.08 - 0.14	0.11 - 0.18	0.14 - 0.22	0.17 - 0.25
0.011 - 0.025	0.023 - 0.032	0.029 - 0.05	0.04 - 0.06	0.05 - 0.07	0.06 - 0.08	0.07 - 0.11	0.10 - 0.14	0.12 - 0.17	0.14 - 0.20
0.014 - 0.032	0.027 - 0.041	0.034 - 0.06	0.05 - 0.08	0.06 - 0.09	0.07 - 0.11	0.08 - 0.14	0.11 - 0.18	0.14 - 0.22	0.17 - 0.25
0.011 - 0.025	0.023 - 0.032	0.029 - 0.05	0.04 - 0.06	0.05 - 0.07	0.06 - 0.08	0.07 - 0.11	0.10 - 0.14	0.12 - 0.17	0.14 - 0.20
0.008 - 0.023	0.020 - 0.030	0.024 - 0.04	0.03 - 0.05	0.04 - 0.07	0.05 - 0.08	0.06 - 0.10	0.08 - 0.13	0.10 - 0.16	0.12 - 0.18
0.011 - 0.025	0.023 - 0.032	0.029 - 0.05	0.04 - 0.06	0.05 - 0.07	0.06 - 0.08	0.07 - 0.11	0.10 - 0.14	0.12 - 0.17	0.14 - 0.20
0.008 - 0.023	0.020 - 0.030	0.024 - 0.04	0.03 - 0.05	0.04 - 0.07	0.05 - 0.08	0.06 - 0.10	0.08 - 0.13	0.10 - 0.16	0.12 - 0.18
0.008 - 0.023	0.020 - 0.030	0.024 - 0.04	0.03 - 0.05	0.04 - 0.07	0.05 - 0.08	0.06 - 0.10	0.08 - 0.13	0.10 - 0.16	0.12 - 0.18
0.011 - 0.025	0.023 - 0.032	0.029 - 0.05	0.04 - 0.06	0.05 - 0.07	0.06 - 0.08	0.07 - 0.11	0.10 - 0.14	0.12 - 0.17	0.14 - 0.20
0.008 - 0.023	0.020 - 0.030	0.024 - 0.04	0.03 - 0.05	0.04 - 0.07	0.05 - 0.08	0.06 - 0.10	0.08 - 0.13	0.10 - 0.16	0.12 - 0.18
0.014 - 0.032	0.027 - 0.041	0.034 - 0.06	0.05 - 0.08	0.06 - 0.09	0.07 - 0.11	0.08 - 0.14	0.11 - 0.18	0.14 - 0.22	0.17 - 0.25
0.017 - 0.050	0.035 - 0.064	0.043 - 0.09	0.06 - 0.12	0.07 - 0.14	0.09 - 0.17	0.11 - 0.22	0.14 - 0.28	0.18 - 0.34	0.22 - 0.39
0.017 - 0.050	0.035 - 0.064	0.043 - 0.09	0.06 - 0.12	0.07 - 0.14	0.09 - 0.17	0.11 - 0.22	0.14 - 0.28	0.18 - 0.34	0.22 - 0.39
0.021 - 0.072	0.049 - 0.092	0.060 - 0.13	0.08 - 0.17	0.10 - 0.20	0.13 - 0.24	0.15 - 0.32	0.20 - 0.40	0.25 - 0.48	0.30 - 0.56
0.017 - 0.050	0.035 - 0.064	0.043 - 0.09	0.06 - 0.21	0.07 - 0.14	0.09 - 0.17	0.11 - 0.22	0.14 - 0.28	0.18 - 0.34	0.22 - 0.39



CONDITIONS DE COUPE

Matières à usiner			CARBURE		DICUT		DLC	
			Vc [m/min]		Vc [m/min]		Vc [m/min]	
P	Acier non allié / faiblement allié	< 600 N/mm ²	40	60	50	70		
P	Acier non allié / faiblement allié	600 – 1500 N/mm ²			30	40		
P	Acier de décolletage au plomb		60	90				
K	Fonte grise / Fonte à graphite sphéroïdal perlitique	< 250 HB	50	80	60	90		
K	Fonte alliée / Fonte à graphite sphéroïdal perlitique	> 250 HB			30	50		
K	Fonte à graphite sphéroïdal ferritique / Fonte malléable				40	60		
S	Titane, alliage de titane		30	50				
N	Alliage de cuivre / bonne usinabilité (laiton – bronze)		80	100			90	110
N	Alliage de cuivre / usinabilité difficile / Bronze à l'aluminium	(CuAlFe) (Ampco)	40	70	50	80	50	80
N	Alliage d'aluminium	Si < 8%	80	130			100	150
N	Fonte d'aluminium	Si > 8%	70	110			90	130
N	Plastique		30	60	50	80	50	80
N	Or, argent		50	80	70	100	70	100



$$n \text{ [tr/min]} = \frac{Vc \text{ [m/min]} \times 1000}{\pi \times D_1 \text{ [mm]}}$$

$$Vf \text{ [mm/min]} = n \text{ [tr/min]} \times f \text{ [mm]}$$

Avance par tour **f [mm]**

$\emptyset D_1$ 0.10 - 0.30	$\emptyset D_1$ 0.30 - 1.00	$\emptyset D_1$ 1.00 - 1.50	$\emptyset D_1$ 1.50 - 2.00	$\emptyset D_1$ 2.00 - 3.00	$\emptyset D_1$ 3.00 - 5.00	$\emptyset D_1$ 5.00 - 7.00	$\emptyset D_1$ 7.00 - 10.00	$\emptyset D_1$ 10.00 - 14.00	$\emptyset D_1$ 14.00 - 16.00
0.002 - 0.004	0.003 - 0.028	0.021 - 0.04	0.03 - 0.05	0.04 - 0.07	0.05 - 0.11	0.08 - 0.14	0.11 - 0.20	0.15 - 0.28	0.21 - 0.32
0.002 - 0.004	0.003 - 0.021	0.018 - 0.03	0.03 - 0.04	0.03 - 0.05	0.04 - 0.08	0.07 - 0.11	0.09 - 0.15	0.13 - 0.21	0.18 - 0.24
0.002 - 0.004	0.003 - 0.028	0.021 - 0.04	0.03 - 0.05	0.04 - 0.07	0.05 - 0.11	0.08 - 0.14	0.11 - 0.20	0.15 - 0.28	0.21 - 0.32
0.002 - 0.004	0.003 - 0.021	0.018 - 0.03	0.03 - 0.04	0.03 - 0.05	0.04 - 0.08	0.07 - 0.11	0.09 - 0.15	0.13 - 0.21	0.18 - 0.24
0.002 - 0.004	0.003 - 0.021	0.015 - 0.03	0.02 - 0.04	0.03 - 0.05	0.04 - 0.07	0.06 - 0.10	0.09 - 0.14	0.11 - 0.20	0.15 - 0.22
0.002 - 0.004	0.003 - 0.020	0.015 - 0.03	0.02 - 0.03	0.03 - 0.05	0.04 - 0.07	0.06 - 0.10	0.08 - 0.14	0.11 - 0.20	0.15 - 0.22
0.002 - 0.004	0.003 - 0.021	0.018 - 0.03	0.03 - 0.04	0.03 - 0.05	0.04 - 0.08	0.07 - 0.11	0.09 - 0.15	0.13 - 0.21	0.18 - 0.24
0.002 - 0.004	0.003 - 0.020	0.015 - 0.03	0.02 - 0.03	0.03 - 0.05	0.04 - 0.07	0.06 - 0.10	0.08 - 0.14	0.11 - 0.20	0.15 - 0.22
0.002 - 0.004	0.003 - 0.028	0.021 - 0.04	0.03 - 0.05	0.04 - 0.07	0.05 - 0.11	0.08 - 0.14	0.11 - 0.20	0.15 - 0.28	0.21 - 0.32
0.002 - 0.004	0.003 - 0.042	0.27 - 0.05	0.04 - 0.07	0.05 - 0.10	0.06 - 0.16	0.10 - 0.21	0.13 - 0.30	0.19 - 0.42	0.27 - 0.48
0.002 - 0.004	0.003 - 0.042	0.27 - 0.05	0.04 - 0.07	0.05 - 0.10	0.06 - 0.16	0.10 - 0.21	0.13 - 0.30	0.19 - 0.42	0.27 - 0.48
0.002 - 0.004	0.003 - 0.059	0.036 - 0.08	0.05 - 0.10	0.06 - 0.14	0.09 - 0.22	0.13 - 0.29	0.18 - 0.42	0.26 - 0.59	0.36 - 0.67
0.002 - 0.004	0.003 - 0.042	0.027 - 0.05	0.04 - 0.07	0.05 - 0.10	0.06 - 0.16	0.10 - 0.21	0.13 - 0.30	0.19 - 0.42	0.27 - 0.48

$D_1 < 1\text{mm} \Rightarrow Vc - 30\%$



CONDITIONS DE COUPE

Matières à usiner			CARBURE		DICUT		DLC	
			Vc [m/min]		Vc [m/min]		Vc [m/min]	
P	Acier non allié / faiblement allié	< 600 N/mm ²	40	60	50	70		
P	Acier non allié / faiblement allié	600 – 1500 N/mm ²			30	40		
P	Acier de décolletage au plomb		60	90				
M	Acier inoxydable	400 – 700 N/mm ²			45	60		
M	Acier inox. DUPLEX, acier austénitique inox. sans nickel	> 800 N/mm ²			30	50		
K	Fonte grise / Fonte à graphite sphéroïdal perlitique	< 250 HB	50	80	60	90		
K	Fonte allié / Fonte à graphite sphéroïdal perlitique	> 250 HB			30	50		
K	Fonte à graphite sphéroïdal ferritique / Fonte malléable				40	60		
S	Super alliages / Acier inox. réfractaire	Inconel Nimonic Hastelloy			20	40		
S	Titane, alliage de titane		30	50				
N	Alliage de cuivre / bonne usinabilité (laiton – bronze)		80	100			90	110
N	Alliage de cuivre / usinabilité difficile / Bronze à l'aluminium	(CuAlFe) (Ampco)	40	70	50	80	50	80
N	Alliage d'aluminium	Si < 8%	80	130			100	150
N	Fonte d'aluminium	Si > 8%	70	110			90	130
N	Graphite						60	100
N	Plastique		30	60	50	80	50	80
N	Or, argent		50	80	70	100	70	100



$$n \text{ [tr/min]} = \frac{Vc \text{ [m/min]} \times 1000}{\pi \times D_1 \text{ [mm]}}$$

$$Vf \text{ [mm/min]} = n \text{ [tr/min]} \times f \text{ [mm]}$$

Avance par tour **f [mm]**

$\emptyset D_1$ 0.05 - 0.30	$\emptyset D_1$ 0.30 - 1.00	$\emptyset D_1$ 1.00 - 1.50	$\emptyset D_1$ 1.50 - 2.00	$\emptyset D_1$ 2.00 - 2.45	
0.002 - 0.004	0.003 - 0.028	0.021 - 0.04	0.03 - 0.05	0.04 - 0.07	
0.002 - 0.004	0.003 - 0.021	0.018 - 0.03	0.03 - 0.04	0.03 - 0.05	
0.002 - 0.004	0.003 - 0.028	0.021 - 0.04	0.03 - 0.05	0.04 - 0.07	
0.002 - 0.004	0.003 - 0.021	0.018 - 0.03	0.03 - 0.04	0.03 - 0.05	
0.002 - 0.004	0.003 - 0.020	0.015 - 0.03	0.02 - 0.03	0.03 - 0.05	
0.002 - 0.004	0.003 - 0.021	0.018 - 0.03	0.03 - 0.04	0.03 - 0.05	
0.002 - 0.004	0.003 - 0.021	0.015 - 0.03	0.02 - 0.04	0.03 - 0.05	
0.002 - 0.004	0.003 - 0.020	0.015 - 0.03	0.02 - 0.03	0.03 - 0.05	
0.002 - 0.004	0.003 - 0.020	0.015 - 0.03	0.02 - 0.03	0.03 - 0.05	
0.002 - 0.004	0.003 - 0.021	0.018 - 0.03	0.03 - 0.04	0.03 - 0.05	
0.002 - 0.004	0.003 - 0.020	0.015 - 0.03	0.02 - 0.03	0.03 - 0.05	
0.002 - 0.004	0.003 - 0.028	0.021 - 0.04	0.03 - 0.05	0.04 - 0.07	
0.002 - 0.004	0.003 - 0.042	0.027 - 0.05	0.04 - 0.07	0.05 - 0.10	
0.002 - 0.004	0.003 - 0.042	0.027 - 0.05	0.04 - 0.07	0.05 - 0.10	
0.002 - 0.004	0.003 - 0.059	0.036 - 0.08	0.05 - 0.10	0.06 - 0.14	
0.002 - 0.004	0.003 - 0.059	0.036 - 0.08	0.05 - 0.10	0.06 - 0.14	
0.002 - 0.004	0.003 - 0.042	0.027 - 0.05	0.04 - 0.07	0.05 - 0.10	

$D_1 < 1\text{mm} \Rightarrow Vc - 30\%$



CONDITIONS DE COUPE

Matières à usiner			CARBURE		DICUT - TiAlN	
			Vc [m/min]		Vc [m/min]	
P	Acier non allié / faiblement allié	< 600 N/mm ²	40	60	50	70
P	Acier de décolletage au plomb		60	90		
P	Acier fortement allié	700 – 1500 N/mm ²			40	60
M	Acier inoxydable	400 – 700 N/mm ²	40	60	50	70
M	Acier inox. DUPLEX, acier austénitique inox. sans nickel	> 800 N/mm ²	20	40	30	50
K	Fonte grise / Fonte à graphite sphéroïdal perlitique	< 250 HB	50	80	60	80
K	Fonte à graphite sphéroïdal ferritique / Fonte malléable		30	50	40	60
S	Super alliages / Acier inox. réfractaire	Inconel Nimonic Hastelloy	15	25	20	40
S	Titane, alliage de titane		35	55		
N	Alliage de cuivre / bonne usinabilité (laiton – bronze)		80	100		
N	Alliage de cuivre / usinabilité difficile / Bronze à l'aluminium	(CuAlFe) (Ampco)	40	70	60	90
N	Alliage d'aluminium	Si < 8%	80	100	90	130
N	Plastique		30	60		
N	Or, argent		50	80		



$$n \text{ [tr/min]} = \frac{Vc \text{ [m/min]} \times 1000}{\pi \times D_1 \text{ [mm]}}$$

$$Vf \text{ [mm/min]} = n \text{ [tr/min]} \times f \text{ [mm]}$$

Avance par tour **f [mm]**

$\emptyset D_1$ 0.20 - 0.40	$\emptyset D_1$ 0.40 - 0.60	$\emptyset D_1$ 0.60 - 0.80	$\emptyset D_1$ 0.80 - 1.00	$\emptyset D_1$ 1.00 - 1.20	$\emptyset D_1$ 1.20 - 1.40	$\emptyset D_1$ 1.40 - 1.60	$\emptyset D_1$ 1.60 - 1.80	$\emptyset D_1$ 1.80 - 2.00	$\emptyset D_1$ 2.00 - 2.80
0.003 - 0.010	0.008 - 0.015	0.012 - 0.018	0.015 - 0.020	0.018 - 0.025	0.022 - 0.030	0.026 - 0.035	0.030 - 0.045	0.034 - 0.055	0.038 - 0.070
0.003 - 0.010	0.008 - 0.015	0.012 - 0.018	0.015 - 0.020	0.018 - 0.025	0.022 - 0.030	0.026 - 0.035	0.030 - 0.045	0.034 - 0.055	0.038 - 0.070
0.003 - 0.010	0.008 - 0.015	0.012 - 0.018	0.015 - 0.020	0.018 - 0.025	0.022 - 0.030	0.026 - 0.035	0.030 - 0.045	0.034 - 0.055	0.038 - 0.070
0.003 - 0.010	0.008 - 0.015	0.012 - 0.018	0.015 - 0.020	0.018 - 0.025	0.022 - 0.030	0.026 - 0.035	0.030 - 0.045	0.034 - 0.055	0.038 - 0.070
0.003 - 0.010	0.008 - 0.015	0.012 - 0.018	0.015 - 0.020	0.018 - 0.025	0.022 - 0.030	0.026 - 0.035	0.030 - 0.045	0.034 - 0.055	0.038 - 0.070
0.003 - 0.010	0.008 - 0.015	0.012 - 0.018	0.015 - 0.020	0.018 - 0.025	0.022 - 0.030	0.026 - 0.035	0.030 - 0.045	0.034 - 0.055	0.038 - 0.070
0.003 - 0.010	0.008 - 0.015	0.012 - 0.018	0.015 - 0.020	0.018 - 0.025	0.022 - 0.030	0.026 - 0.035	0.030 - 0.045	0.034 - 0.055	0.038 - 0.070
0.003 - 0.010	0.008 - 0.015	0.012 - 0.018	0.015 - 0.020	0.018 - 0.025	0.022 - 0.030	0.026 - 0.035	0.030 - 0.045	0.034 - 0.055	0.038 - 0.070
0.003 - 0.010	0.008 - 0.015	0.012 - 0.018	0.015 - 0.020	0.018 - 0.025	0.022 - 0.030	0.026 - 0.035	0.030 - 0.045	0.034 - 0.055	0.038 - 0.070
0.003 - 0.010	0.008 - 0.015	0.012 - 0.018	0.015 - 0.020	0.018 - 0.025	0.022 - 0.030	0.026 - 0.035	0.030 - 0.045	0.034 - 0.055	0.038 - 0.070
0.003 - 0.010	0.008 - 0.015	0.012 - 0.018	0.015 - 0.020	0.018 - 0.025	0.022 - 0.030	0.026 - 0.035	0.030 - 0.045	0.034 - 0.055	0.038 - 0.070
0.003 - 0.010	0.008 - 0.015	0.012 - 0.018	0.015 - 0.020	0.018 - 0.025	0.022 - 0.030	0.026 - 0.035	0.030 - 0.045	0.034 - 0.055	0.038 - 0.070
0.003 - 0.010	0.008 - 0.015	0.012 - 0.018	0.015 - 0.020	0.018 - 0.025	0.022 - 0.030	0.026 - 0.035	0.030 - 0.045	0.034 - 0.055	0.038 - 0.070
0.003 - 0.010	0.008 - 0.015	0.012 - 0.018	0.015 - 0.020	0.018 - 0.025	0.022 - 0.030	0.026 - 0.035	0.030 - 0.045	0.034 - 0.055	0.038 - 0.070
0.003 - 0.010	0.008 - 0.015	0.012 - 0.018	0.015 - 0.020	0.018 - 0.025	0.022 - 0.030	0.026 - 0.035	0.030 - 0.045	0.034 - 0.055	0.038 - 0.070

$D_1 < 1\text{mm} \Rightarrow Vc - 30\%$



CONDITIONS DE COUPE

Matières à usiner

			CARBURE		DICUT - TiAlN	
			Vc [m/min]		Vc [m/min]	
P	Acier non allié / faiblement allié	< 600 N/mm ²	40	60	50	70
P	Acier de décolletage au plomb		60	90		
P	Acier fortement allié	700 – 1500 N/mm ²	15	30	20	40
M	Acier inoxydable	400 – 700 N/mm ²	35	50	40	60
K	Fonte grise / Fonte à graphite sphéroïdal perlitique	< 250 HB	50	80	60	80
K	Fonte à graphite sphéroïdal ferritique / Fonte malléable		30	50	40	60
S	Titane, alliage de titane		30	50		
N	Alliage de cuivre / bonne usinabilité (laiton – bronze)		80	100		
N	Alliage de cuivre / usinabilité difficile / Bronze à l'aluminium	(CuAlFe) (Ampco)	40	70	50	80
N	Alliage d'aluminium	Si < 8%	80	100	90	110
N	Plastique		30	60		
N	Or, argent		50	80		



$$n \text{ [tr/min]} = \frac{Vc \text{ [m/min]} \times 1000}{\pi \times D_1 \text{ [mm]}}$$

$$Vf \text{ [mm/min]} = n \text{ [tr/min]} \times f \text{ [mm]}$$

Avance par tour **f [mm]**

$\emptyset D_1$ 0.20 - 0.70	$\emptyset D_1$ 0.70 - 1.00	$\emptyset D_1$ 1.00 - 1.50	$\emptyset D_1$ 1.50 - 2.00	$\emptyset D_1$ 2.00 - 3.00	$\emptyset D_1$ 3.00 - 4.00	$\emptyset D_1$ 4.00 - 5.00	$\emptyset D_1$ 5.00 - 6.00
0.005 - 0.013	0.010 - 0.018	0.014 - 0.04	0.02 - 0.05	0.04 - 0.06	0.04 - 0.09	0.06 - 0.10	0.08 - 0.11
0.005 - 0.013	0.010 - 0.018	0.014 - 0.04	0.02 - 0.05	0.04 - 0.06	0.04 - 0.09	0.06 - 0.10	0.08 - 0.11
0.003 - 0.009	0.007 - 0.013	0.010 - 0.03	0.02 - 0.05	0.03 - 0.04	0.03 - 0.06	0.04 - 0.07	0.06 - 0.08
0.005 - 0.010	0.008 - 0.014	0.012 - 0.03	0.02 - 0.035	0.03 - 0.05	0.04 - 0.07	0.05 - 0.08	0.07 - 0.08
0.004 - 0.010	0.008 - 0.014	0.012 - 0.03	0.02 - 0.035	0.03 - 0.05	0.04 - 0.07	0.05 - 0.08	0.07 - 0.08
0.004 - 0.010	0.008 - 0.014	0.012 - 0.03	0.02 - 0.04	0.03 - 0.05	0.04 - 0.07	0.05 - 0.08	0.07 - 0.08
0.003 - 0.009	0.007 - 0.013	0.010 - 0.03	0.02 - 0.04	0.03 - 0.04	0.03 - 0.06	0.04 - 0.07	0.06 - 0.08
0.006 - 0.020	0.013 - 0.028	0.018 - 0.05	0.03 - 0.06	0.05 - 0.09	0.05 - 0.13	0.07 - 0.15	0.10 - 0.17
0.005 - 0.013	0.010 - 0.018	0.014 - 0.04	0.02 - 0.05	0.04 - 0.06	0.04 - 0.09	0.06 - 0.10	0.08 - 0.11
0.006 - 0.020	0.013 - 0.028	0.018 - 0.05	0.03 - 0.06	0.05 - 0.09	0.05 - 0.13	0.07 - 0.15	0.10 - 0.17
0.008 - 0.028	0.018 - 0.040	0.025 - 0.08	0.04 - 0.08	0.07 - 0.13	0.08 - 0.19	0.10 - 0.22	0.14 - 0.24
0.006 - 0.020	0.013 - 0.028	0.018 - 0.05	0.03 - 0.06	0.05 - 0.09	0.05 - 0.13	0.07 - 0.15	0.10 - 0.17

$D_1 < 1\text{mm} \Rightarrow Vc - 30\%$



CONDITIONS DE COUPE

Matières à usiner			Ø D ₁ < 2.00		Ø D ₁ ≥ 2.00	
			TiAlN Vc [m/min]		TiAlN Vc [m/min]	
P	Acier non allié / faiblement allié	< 600 N/mm ²	30	60	70	90
P	Acier non allié / faiblement allié	600 – 1500 N/mm ²	35	50	40	60
P	Acier fortement allié	700 – 1500 N/mm ²	15	30	70	90
M	Acier inoxydable	400 – 700 N/mm ²	10	25	35	50
K	Fonte grise / Fonte à graphite sphéroïdal perlitique	< 250 HB	30	60	70	100
K	Fonte alliée / Fonte à graphite sphéroïdal perlitique	> 250 HB	10	25	50	80
K	Fonte à graphite sphéroïdal ferritique / Fonte malléable		15	30	50	80
S	Super alliages / Acier inox. réfractaire	Inconel Nimonic Hastelloy	10	25	15	35
S	Titane, alliage de titane		20	45	40	70
N	Alliage de cuivre / usinabilité difficile / Bronze à l'aluminium	(CuAlFe) (Ampco)	50	90	90	110

DIXI 1149

			TiAlN Vc [m/min]	
P	Acier non allié / faiblement allié	< 600 N/mm ²	70	90
P	Acier non allié / faiblement allié	600 – 1500 N/mm ²	40	60
P	Acier fortement allié	700 – 1500 N/mm ²	35	50
M	Acier inoxydable	400 – 700 N/mm ²	35	50
K	Fonte grise / Fonte à graphite sphéroïdal perlitique	< 250 HB	70	100
K	Fonte alliée / Fonte à graphite sphéroïdal perlitique	> 250 HB	40	60
K	Fonte à graphite sphéroïdal ferritique / Fonte malléable		30	50
S	Super alliages / Acier inox. réfractaire	Inconel Nimonic Hastelloy	12	30
S	Titane, alliage de titane		30	60
N	Alliage de cuivre / usinabilité difficile / Bronze à l'aluminium	(CuAlFe) (Ampco)	70	90
N	Alliage d'aluminium	Si < 8%	130	160



$$n \text{ [tr/min]} = \frac{Vc \text{ [m/min]} \times 1000}{\pi \times D_1 \text{ [mm]}}$$

$$Vf \text{ [mm/min]} = n \text{ [tr/min]} \times f \text{ [mm]}$$

Avance par tour **f [mm]**

Ø D ₁ < 1.00	Ø D ₁ 1.00 - 2.00	Ø D ₁ 2.00 - 3.00	Ø D ₁ 3.00 - 4.50	Ø D ₁ 4.50 - 6.00	Ø D ₁ 6.00 - 7.00	Ø D ₁ 7.00 - 8.00	Ø D ₁ 8.00 - 10.00	Ø D ₁ 10.00 - 12.00	Ø D ₁ 12.00 - 14.00
0.02 - 0.03	0.03 - 0.05	0.03 - 0.06	0.04 - 0.10	0.08 - 0.12	0.10 - 0.14	0.11 - 0.16	0.13 - 0.20	0.15 - 0.25	0.20 - 0.30
0.01 - 0.02	0.015 - 0.04	0.02 - 0.05	0.04 - 0.08	0.07 - 0.09	0.08 - 0.11	0.09 - 0.12	0.10 - 0.15	0.13 - 0.18	0.16 - 0.20
0.005 - 0.008	0.007 - 0.012	0.01 - 0.04	0.03 - 0.08	0.07 - 0.09	0.08 - 0.11	0.09 - 0.12	0.10 - 0.15	0.13 - 0.18	0.16 - 0.20
0.005 - 0.008	0.009 - 0.02	0.008 - 0.04	0.03 - 0.08	0.06 - 0.09	0.07 - 0.11	0.08 - 0.12	0.09 - 0.15	0.12 - 0.18	0.15 - 0.20
0.02 - 0.03	0.03 - 0.04	0.04 - 0.05	0.04 - 0.08	0.07 - 0.09	0.08 - 0.11	0.09 - 0.12	0.10 - 0.15	0.13 - 0.18	0.16 - 0.20
0.01 - 0.02	0.02 - 0.03	0.03 - 0.04	0.03 - 0.08	0.06 - 0.09	0.07 - 0.11	0.08 - 0.12	0.09 - 0.15	0.12 - 0.18	0.15 - 0.20
0.02 - 0.03	0.03 - 0.04	0.04 - 0.05	0.04 - 0.08	0.07 - 0.09	0.08 - 0.11	0.09 - 0.12	0.10 - 0.15	0.13 - 0.18	0.16 - 0.20
0.008 - 0.02	0.01 - 0.03	0.01 - 0.04	0.03 - 0.08	0.06 - 0.09	0.07 - 0.11	0.08 - 0.12	0.09 - 0.15	0.12 - 0.18	0.15 - 0.20
0.008 - 0.02	0.01 - 0.03	0.01 - 0.04	0.03 - 0.08	0.06 - 0.09	0.07 - 0.11	0.08 - 0.12	0.09 - 0.15	0.12 - 0.18	0.15 - 0.20
0.03 - 0.04	0.04 - 0.05	0.045 - 0.06	0.04 - 0.10	0.08 - 0.12	0.10 - 0.14	0.11 - 0.16	0.13 - 0.20	0.16 - 0.25	0.20 - 0.30

Ø D ₁ 1.00 - 2.00	Ø D ₁ 2.00 - 3.00	Ø D ₁ 3.00 - 4.00	Ø D ₁ 4.00 - 5.00	Ø D ₁ 5.00 - 6.00	Ø D ₁ 6.00 - 7.00	Ø D ₁ 7.00 - 8.00	Ø D ₁ 8.00 - 9.00	Ø D ₁ 9.00 - 10.00	Ø D ₁ 10.00 - 14.00
0.02 - 0.04	0.03 - 0.06	0.04 - 0.09	0.06 - 0.11	0.08 - 0.12	0.10 - 0.14	0.11 - 0.16	0.13 - 0.18	0.15 - 0.20	0.15 - 0.30
0.02 - 0.04	0.02 - 0.05	0.04 - 0.07	0.05 - 0.08	0.07 - 0.09	0.08 - 0.11	0.09 - 0.12	0.10 - 0.14	0.12 - 0.15	0.13 - 0.20
0.01 - 0.03	0.01 - 0.40	0.03 - 0.07	0.05 - 0.08	0.07 - 0.09	0.07 - 0.11	0.08 - 0.12	0.09 - 0.14	0.12 - 0.15	0.12 - 0.20
0.01 - 0.03	0.01 - 0.04	0.03 - 0.07	0.05 - 0.08	0.07 - 0.09	0.08 - 0.11	0.09 - 0.12	0.09 - 0.14	0.12 - 0.15	0.12 - 0.20
0.02 - 0.04	0.04 - 0.05	0.04 - 0.07	0.05 - 0.08	0.07 - 0.09	0.08 - 0.11	0.09 - 0.12	0.10 - 0.14	0.12 - 0.15	0.13 - 0.20
0.02 - 0.04	0.04 - 0.05	0.04 - 0.07	0.05 - 0.08	0.07 - 0.09	0.08 - 0.11	0.09 - 0.12	0.10 - 0.14	0.12 - 0.15	0.13 - 0.20
0.02 - 0.04	0.03 - 0.04	0.03 - 0.07	0.05 - 0.08	0.07 - 0.09	0.07 - 0.11	0.08 - 0.12	0.09 - 0.14	0.12 - 0.15	0.12 - 0.20
0.008 - 0.03	0.01 - 0.03	0.03 - 0.07	0.05 - 0.08	0.07 - 0.09	0.07 - 0.11	0.08 - 0.12	0.09 - 0.14	0.12 - 0.15	0.12 - 0.20
0.008 - 0.03	0.01 - 0.03	0.03 - 0.07	0.05 - 0.08	0.07 - 0.09	0.07 - 0.12	0.08 - 0.12	0.09 - 0.14	0.12 - 0.15	0.12 - 0.20
0.02 - 0.04	0.02 - 0.06	0.05 - 0.08	0.06 - 0.10	0.08 - 0.12	0.10 - 0.14	0.11 - 0.16	0.13 - 0.18	0.13 - 0.20	0.16 - 0.30
0.02 - 0.04	0.02 - 0.06	0.05 - 0.08	0.06 - 0.10	0.08 - 0.12	0.10 - 0.14	0.11 - 0.16	0.13 - 0.18	0.13 - 0.20	0.16 - 0.30



CONDITIONS DE COUPE

Matières à usiner

			TiAlN	
			Vc [m/min]	
P	Acier non allié / faiblement allié	< 600 N/mm ²	80	120
P	Acier non allié / faiblement allié	600 – 1500 N/mm ²	70	100
P	Acier de décolletage au plomb		80	120
P	Acier fortement allié	700 – 1500 N/mm ²	40	70
M	Acier inox. DUPLEX, acier austénitique inox. sans nickel	> 800 N/mm ²	30	50
K	Fonte grise / Fonte à graphite sphéroïdal perlitique	< 250 HB	90	130
K	Fonte allié / Fonte à graphite sphéroïdal perlitique	> 250 HB	80	120
K	Fonte à graphite sphéroïdal ferritique / Fonte malléable		70	100
S	Super alliages / Acier inox. réfractaire	Inconel Nimonic Hastelloy	15	30
S	Titane, alliage de titane		50	100

DIXI 1147

			TiAlN	
			Vc [m/min]	
P	Acier non allié / faiblement allié	< 600 N/mm ²	70	100
P	Acier non allié / faiblement allié	600 – 1500 N/mm ²	60	90
P	Acier de décolletage au plomb		80	110
P	Acier fortement allié	700 – 1500 N/mm ²	30	60
M	Acier inox. DUPLEX, acier austénitique inox. sans nickel	> 800 N/mm ²	30	50
K	Fonte grise / Fonte à graphite sphéroïdal perlitique	< 250 HB	90	130
K	Fonte allié / Fonte à graphite sphéroïdal perlitique	> 250 HB	80	120
K	Fonte à graphite sphéroïdal ferritique / Fonte malléable		70	100
S	Super alliages / Acier inox. réfractaire	Inconel Nimonic Hastelloy	15	30
N	Alliage d'aluminium	Si < 8%	130	160



$$n \text{ [tr/min]} = \frac{V_c \text{ [m/min]} \times 1000}{\pi \times D_1 \text{ [mm]}}$$

$$V_f \text{ [mm/min]} = n \text{ [tr/min]} \times f \text{ [mm]}$$

Avance par tour **f [mm]**

$\emptyset D_1$ 0.80 - 1.00	$\emptyset D_1$ 1.00 - 1.50	$\emptyset D_1$ 1.50 - 2.00	$\emptyset D_1$ 2.00 - 3.00	$\emptyset D_1$ 3.00 - 5.00	$\emptyset D_1$ 5.00 - 7.00	$\emptyset D_1$ 7.00 - 10.00	
0.03 - 0.11	0.06 - 0.16	0.08 - 0.21	0.11 - 0.25	0.13 - 0.27	0.16 - 0.33	0.19 - 0.35	
0.03 - 0.10	0.06 - 0.15	0.08 - 0.20	0.10 - 0.23	0.12 - 0.25	0.15 - 0.27	0.18 - 0.30	
0.03 - 0.12	0.07 - 0.17	0.09 - 0.23	0.11 - 0.25	0.14 - 0.27	0.17 - 0.30	0.21 - 0.35	
0.03 - 0.10	0.06 - 0.15	0.08 - 0.17	0.12 - 0.22	0.12 - 0.23	0.15 - 0.25	0.18 - 0.28	
0.008 - 0.02	0.01 - 0.04	0.02 - 0.06	0.03 - 0.08	0.04 - 0.10	0.05 - 0.12	0.07 - 0.14	
0.03 - 0.12	0.07 - 0.17	0.09 - 0.23	0.12 - 0.29	0.14 - 0.35	0.17 - 0.40	0.21 - 0.46	
0.03 - 0.12	0.07 - 0.17	0.09 - 0.23	0.12 - 0.29	0.14 - 0.35	0.17 - 0.40	0.21 - 0.46	
0.03 - 0.10	0.06 - 0.15	0.08 - 0.20	0.10 - 0.25	0.12 - 0.30	0.15 - 0.35	0.18 - 0.40	
0.008 - 0.02	0.01 - 0.04	0.02 - 0.06	0.03 - 0.08	0.04 - 0.10	0.05 - 0.12	0.07 - 0.14	
0.008 - 0.02	0.01 - 0.04	0.02 - 0.06	0.03 - 0.08	0.04 - 0.10	0.05 - 0.12	0.07 - 0.14	

$\emptyset D_1$ 0.50 - 1.00	$\emptyset D_1$ 1.00 - 1.50	$\emptyset D_1$ 1.50 - 2.00	$\emptyset D_1$ 2.00 - 3.00	$\emptyset D_1$ 3.00 - 5.00	$\emptyset D_1$ 5.00 - 7.00	$\emptyset D_1$ 7.00 - 10.00	
0.03 - 0.11	0.06 - 0.16	0.08 - 0.21	0.11 - 0.26	0.13 - 0.32	0.16 - 0.37	0.19 - 0.42	
0.03 - 0.10	0.06 - 0.15	0.08 - 0.20	0.10 - 0.25	0.12 - 0.30	0.15 - 0.35	0.18 - 0.40	
0.03 - 0.12	0.07 - 0.17	0.09 - 0.23	0.12 - 0.29	0.14 - 0.35	0.17 - 0.40	0.21 - 0.46	
0.03 - 0.10	0.06 - 0.15	0.08 - 0.20	0.12 - 0.25	0.12 - 0.30	0.15 - 0.35	0.18 - 0.40	
0.008 - 0.02	0.01 - 0.04	0.02 - 0.06	0.03 - 0.08	0.04 - 0.10	0.05 - 0.12	0.07 - 0.14	
0.03 - 0.12	0.07 - 0.17	0.09 - 0.23	0.12 - 0.29	0.14 - 0.35	0.17 - 0.40	0.21 - 0.46	
0.03 - 0.12	0.07 - 0.17	0.09 - 0.23	0.12 - 0.29	0.14 - 0.35	0.17 - 0.40	0.21 - 0.46	
0.03 - 0.10	0.06 - 0.15	0.08 - 0.20	0.10 - 0.25	0.12 - 0.30	0.15 - 0.35	0.18 - 0.40	
0.008 - 0.02	0.01 - 0.04	0.02 - 0.06	0.03 - 0.08	0.04 - 0.10	0.05 - 0.12	0.07 - 0.14	
0.03 - 0.10	0.06 - 0.15	0.08 - 0.20	0.10 - 0.25	0.12 - 0.30	0.15 - 0.35	0.18 - 0.40	



CONDITIONS DE COUPE

Matières à usiner

			CARBURE	
			Vc [m/min]	
P	Acier non allié / faiblement allié	< 600 N/mm ²	40	60
P	Acier non allié / faiblement allié	600 – 1500 N/mm ²	35	50
P	Acier de décolletage au plomb		60	90
K	Fonte grise / Fonte à graphite sphéroïdal perlitique	< 250 HB	50	80
K	Fonte à graphite sphéroïdal ferritique / Fonte malléable		40	55
S	Titane, alliage de titane		30	50
N	Alliage de cuivre / bonne usinabilité (laiton – bronze)		60	100
N	Fonte d'aluminium	Si > 8%	70	110
N	Or, argent		50	80

DIXI 1280

			XIDUR	
			Vc [m/min]	
H	Acier à outils et fontes trempés	> 1500 N/mm ² (45 - 65 HRC)	15	25
S	Super alliages / Acier inox. réfractaire	Inconel Nimonic Hastelloy	15	30



$$n \text{ [tr/min]} = \frac{V_c \text{ [m/min]} \times 1000}{\pi \times D_1 \text{ [mm]}}$$

$$V_f \text{ [mm/min]} = n \text{ [tr/min]} \times f \text{ [mm]}$$

Avance par tour **f [mm]**

$\emptyset D_1$ 0.20 - 0.50	$\emptyset D_1$ 0.50 - 1.00	$\emptyset D_1$ 1.00 - 1.50	$\emptyset D_1$ 1.50 - 2.00	$\emptyset D_1$ 2.00 - 3.00	$\emptyset D_1$ 3.00 - 5.00	$\emptyset D_1$ 5.00 - 7.00	$\emptyset D_1$ 7.00 - 10.00	$\emptyset D_1$ 10.00 - 14.00
0.004 - 0.008	0.006 - 0.017	0.015 - 0.025	0.02 - 0.035	0.030 - 0.04	0.035 - 0.08	0.07 - 0.18	0.15 - 0.25	0.18 - 0.30
0.004 - 0.008	0.006 - 0.017	0.015 - 0.025	0.02 - 0.035	0.030 - 0.04	0.035 - 0.08	0.07 - 0.18	0.15 - 0.25	0.18 - 0.30
0.004 - 0.008	0.006 - 0.017	0.015 - 0.025	0.02 - 0.035	0.030 - 0.04	0.035 - 0.08	0.07 - 0.18	0.15 - 0.25	0.18 - 0.30
0.004 - 0.008	0.006 - 0.017	0.015 - 0.025	0.02 - 0.035	0.030 - 0.04	0.035 - 0.08	0.07 - 0.18	0.15 - 0.25	0.18 - 0.30
0.004 - 0.008	0.006 - 0.017	0.015 - 0.025	0.02 - 0.035	0.030 - 0.04	0.035 - 0.08	0.07 - 0.18	0.15 - 0.25	0.18 - 0.30
0.004 - 0.008	0.006 - 0.017	0.015 - 0.025	0.02 - 0.035	0.030 - 0.04	0.035 - 0.08	0.07 - 0.18	0.15 - 0.25	0.18 - 0.30
0.004 - 0.008	0.006 - 0.017	0.015 - 0.025	0.02 - 0.035	0.030 - 0.04	0.035 - 0.08	0.07 - 0.18	0.15 - 0.25	0.18 - 0.30
0.004 - 0.008	0.006 - 0.017	0.015 - 0.025	0.02 - 0.035	0.030 - 0.04	0.035 - 0.08	0.07 - 0.18	0.15 - 0.25	0.18 - 0.30

$D_1 < 1\text{mm} \Rightarrow V_c - 30\%$

$\emptyset D_1$ 0.25 - 0.50	$\emptyset D_1$ 0.50 - 1.00	$\emptyset D_1$ 1.00 - 2.50	$\emptyset D_1$ 2.50 - 3.00	$\emptyset D_1$ 3.00 - 4.00	$\emptyset D_1$ 4.00 - 5.00	$\emptyset D_1$ 5.00 - 8.00	$\emptyset D_1$ 8.00 - 12.00
0.01	0.02	0.025	0.03	0.04	0.05	0.05	0.06
0.01	0.02	0.025	0.03	0.04	0.05	0.05	0.06

Cycle de débourage = $0.25 \times D_1$



CONDITIONS DE COUPE

Matières à usiner			CARBURE		TiAlN	
			Vc [m/min]		Vc [m/min]	
P	Acier non allié / faiblement allié	< 600 N/mm ²	40	60	50	70
P	Acier non allié / faiblement allié	600 – 1500 N/mm ²	30	50	40	60
P	Acier de décolletage au plomb		60	90	70	100
P	Acier fortement allié	700 – 1500 N/mm ²	35	50	25	50
M	Acier inoxydable	400 – 700 N/mm ²	15	40	40	60
M	Acier inox. DUPLEX, acier austénitique inox. sans nickel	> 800 N/mm ²	30	50	40	60
K	Fonte grise / Fonte à graphite sphéroïdal perlitique	< 250 HB	10	30	60	90
K	Fonte alliée / Fonte à graphite sphéroïdal perlitique	> 250 HB	50	80	40	60
K	Fonte à graphite sphéroïdal ferritique / Fonte malléable		30	50	40	60
S	Super alliages / Acier inox. réfractaire	Inconel Nimonic Hastelloy	20	40	30	50
S	Titane, alliage de titane		30	50	40	60
N	Alliage de cuivre / bonne usinabilité (laiton – bronze)		80	100	90	120
N	Alliage de cuivre / usinabilité difficile / Bronze à l'aluminium	(CuAlFe) (Ampeco)	40	70	60	80
N	Alliage d'aluminium	Si < 8%	80	120	100	160
N	Fonte d'aluminium	Si > 8%	70	110	90	130
N	Plastique		30	60	50	80
N	Or, argent		50	80	65	100

On utilise généralement le **Ø moyen** du foret étagé pour le calcul de la rotation de la broche (n)



$$n \text{ [tr/min]} = \frac{Vc \text{ [m/min]} \times 1000}{\pi \times D_1 \text{ [mm]}}$$

$$Vf \text{ [mm/min]} = n \text{ [tr/min]} \times f \text{ [mm]}$$

Avance par tour **f [mm]**

$\emptyset D_1$ 0.30 - 1.00	$\emptyset D_1$ 1.00 - 1.50	$\emptyset D_1$ 1.50 - 2.00	$\emptyset D_1$ 2.00 - 3.00	$\emptyset D_1$ 3.00 - 5.00	$\emptyset D_1$ 5.00 - 7.00	$\emptyset D_1$ 7.00 - 10.00	$\emptyset D_1$ 10.00 - 14.00	$\emptyset D_1$ 14.00 - 16.00	$\emptyset D_1$ 16.00 - 20.00
0.003 - 0.018	0.014 - 0.027	0.021 - 0.04	0.03 - 0.05	0.04 - 0.09	0.07 - 0.13	0.10 - 0.18	0.14 - 0.25	0.20 - 0.29	0.22 - 0.36
0.002 - 0.014	0.012 - 0.021	0.018 - 0.03	0.02 - 0.04	0.04 - 0.07	0.06 - 0.10	0.08 - 0.14	0.12 - 0.20	0.17 - 0.22	0.19 - 0.28
0.003 - 0.018	0.014 - 0.027	0.021 - 0.04	0.03 - 0.05	0.04 - 0.09	0.07 - 0.13	0.10 - 0.18	0.14 - 0.25	0.20 - 0.29	0.22 - 0.36
0.002 - 0.014	0.012 - 0.021	0.018 - 0.03	0.02 - 0.04	0.04 - 0.07	0.06 - 0.10	0.08 - 0.14	0.12 - 0.20	0.17 - 0.22	0.19 - 0.28
0.002 - 0.013	0.010 - 0.020	0.015 - 0.03	0.02 - 0.03	0.03 - 0.07	0.05 - 0.09	0.07 - 0.13	0.10 - 0.18	0.14 - 0.21	0.16 - 0.26
0.002 - 0.014	0.012 - 0.021	0.018 - 0.03	0.02 - 0.04	0.04 - 0.07	0.06 - 0.10	0.08 - 0.14	0.12 - 0.20	0.17 - 0.22	0.19 - 0.28
0.002 - 0.013	0.010 - 0.02	0.015 - 0.03	0.02 - 0.03	0.03 - 0.07	0.05 - 0.09	0.07 - 0.13	0.10 - 0.18	0.14 - 0.21	0.16 - 0.26
0.002 - 0.014	0.012 - 0.021	0.018 - 0.03	0.02 - 0.04	0.04 - 0.07	0.06 - 0.10	0.08 - 0.14	0.12 - 0.20	0.17 - 0.22	0.19 - 0.28
0.002 - 0.013	0.010 - 0.020	0.015 - 0.03	0.02 - 0.03	0.03 - 0.07	0.05 - 0.09	0.07 - 0.13	0.10 - 0.18	0.14 - 0.21	0.16 - 0.26
0.002 - 0.014	0.012 - 0.021	0.018 - 0.03	0.02 - 0.04	0.04 - 0.07	0.06 - 0.10	0.08 - 0.14	0.12 - 0.20	0.17 - 0.22	0.19 - 0.28
0.002 - 0.013	0.010 - 0.020	0.015 - 0.03	0.02 - 0.03	0.03 - 0.07	0.05 - 0.09	0.07 - 0.13	0.10 - 0.18	0.14 - 0.21	0.16 - 0.26
0.004 - 0.028	0.018 - 0.042	0.027 - 0.06	0.04 - 0.07	0.05 - 0.14	0.09 - 0.20	0.13 - 0.28	0.18 - 0.39	0.25 - 0.45	0.29 - 0.56
0.003 - 0.018	0.014 - 0.027	0.021 - 0.04	0.03 - 0.05	0.04 - 0.09	0.07 - 0.13	0.10 - 0.18	0.14 - 0.25	0.20 - 0.29	0.22 - 0.36
0.004 - 0.028	0.018 - 0.042	0.027 - 0.06	0.04 - 0.07	0.05 - 0.14	0.09 - 0.20	0.13 - 0.28	0.18 - 0.39	0.25 - 0.45	0.29 - 0.56
0.004 - 0.028	0.018 - 0.042	0.027 - 0.06	0.04 - 0.07	0.05 - 0.14	0.09 - 0.20	0.13 - 0.28	0.18 - 0.39	0.25 - 0.45	0.29 - 0.56
0.005 - 0.040	0.025 - 0.060	0.038 - 0.08	0.05 - 0.10	0.08 - 0.20	0.13 - 0.28	0.18 - 0.40	0.25 - 0.56	0.35 - 0.64	0.40 - 0.80
0.004 - 0.028	0.018 - 0.042	0.027 - 0.06	0.04 - 0.07	0.05 - 0.14	0.09 - 0.20	0.13 - 0.28	0.18 - 0.39	0.25 - 0.45	0.29 - 0.56

$D_1 < 1\text{mm} \Rightarrow Vc - 30\%$





FRAISAGE

FRÄSEN

MILLING

FRESATURA

MARÁS

	SÉLECTION DES FRAISES	96
	FRAISES EN BOUT Z = 1	110
	FRAISES EN BOUT Z = 2	115
	FRAISES EN BOUT Z = 3	127
	FRAISES EN BOUT Z = 4	139
	FRAISES MULTIDENTS	143
	FRAISES TORIQUES	145
	FRAISES HÉMISPHÉRIQUES	151
	FRAISES DIAMANT	160
	FRAISES À CHANFREINER ET À RAYONNER	166
	FRAISES POUR COMPOSITES / KEVLAR®	168
	OUTILS SUR DEMANDE	169
	INFORMATIONS	170
	CONDITIONS DE COUPE	171

SELECTION DES FRAISES

✓ = article de stock

FRAISES EN BOUT Z=1		Z	Page			<input type="checkbox"/> CARBURE	<input checked="" type="checkbox"/> TITAIN	<input checked="" type="checkbox"/> DIAMANT		
DIXI 7561 Ø 2.00 - 12.00		1	110	$L_1 = 2-3 \times \varnothing$		✓				
DIXI 7301 Ø 2.00 - 8.00		1	111	$L_1 = 2.5-4 \times \varnothing$		✓				
DIXI 7302 Ø 3.00 - 12.00		1	111	$L_1 = 2.5-6 \times \varnothing$		✓				
DIXI 7303 Ø 2.00 - 5.00		1	112	$L_1 = 4-6 \times \varnothing$		✓				
DIXI 7060 Ø 0.50 - 6.00		1	113	$L_1 = 1-2 \times \varnothing$		✓				
DIXI 7063 Ø 0.40 - 4.00		1	114	$L_1 = 1-2.5 \times \varnothing$		✓				
FRAISES EN BOUT Z=2		Z	Page							
DIXI 7242 Ø 0.15 - 20.00		2	115	$L_1 = 1.5-5 \times \varnothing$ 		✓	✓			
DIXI 7202 Ø 1.50 - 16.00		2	117	$L_1 = 1.5-4 \times \varnothing$		✓	✓	✓		
DIXI 7222 Ø 3.00 - 20.00		2	118	$L_1 = 3-10 \times \varnothing$		✓	✓	✓		
DIXI 7240 Ø 0.04 - 5.50		2	119	$L_1 = 1 \times \varnothing$		✓	✓			
DIXI 7237 Ø 0.15 - 3.00		2	121	$L_1 = 1 \times \varnothing$ $L_2 = 3 \times \varnothing$		✓	✓			
DIXI 7238 Ø 0.30 - 3.00		2	121	$L_1 = 1 \times \varnothing$ $L_2 = 5 \times \varnothing$		✓	✓			
DIXI 7239 Ø 0.40 - 3.00		2	121	$L_1 = 1 \times \varnothing$ $L_2 = 8 \times \varnothing$		✓	✓			



○ bien ⊙ excellent

Acier + Pb	Acier faibl. allié	Aciers fort. allié	Acier inox aust.	Aciers Fontes 45-65 HRC	Fontes	Super alliages Ni / Co	Titane, alliages de titane	Alliage Cu Argent Or	Alliage Cu difficile	Alu	Graphite	Plastique
------------	--------------------	--------------------	------------------	-------------------------	--------	------------------------	----------------------------	----------------------	----------------------	-----	----------	-----------

								○		⊙		○
												⊙
												⊙
												⊙
○					○			⊙	○	○		○
○					○			⊙	○	○		○

⊙	○	○	○		⊙		⊙	⊙	⊙	○		○
⊙	○		○				○	⊙	○	○	⊙	○
⊙	○		○				○	⊙	○	○	⊙	○
⊙	○	○	○		⊙	○	⊙	⊙	⊙	○		○
⊙	○	○	○		⊙	○	⊙	⊙	⊙	○		○
⊙	○	○	○		⊙	○	⊙	⊙	⊙	○		○
⊙	○	○	○		⊙	○	⊙	⊙	⊙	○		○



SELECTION DES FRAISES

✓ = article de stock

FRAISES EN BOUT Z=2		Z	Page		<input type="checkbox"/> CARBURE	<input checked="" type="checkbox"/> TAIN	<input checked="" type="checkbox"/> CUTINOX	<input checked="" type="checkbox"/> DIAMANT
DIXI 7239-10D Ø 0.50 - 3.00		2	121	L ₁ = 1 x Ø L ₂ = 10 x Ø		✓	✓	
DIXI 7239-12D Ø 0.50 - 1.70		2	121	L ₁ = 1 x Ø L ₂ = 12 x Ø		✓	✓	
DIXI 7239-15D Ø 0.50 - 1.35		2	121	L ₁ = 1 x Ø L ₂ = 15 x Ø		✓	✓	
DIXI 7582 Ø 1.00 - 5.50		2	125	L ₁ = 2 x Ø		✓	✓	
DIXI 7562 Ø 6.00 - 20.00		2	125	L ₁ = 1.5 x Ø		✓	✓	
DIXI 7572 Ø 3.00 - 20.00		2	126	L ₁ = 3-5 x Ø		✓	✓	✓
DIXI 7232 Ø 2.00 - 8.00		2	126	L ₁ = 1.5-3 x Ø 		✓		

FRAISES EN BOUT Z=3

DIXI 7243 Ø 0.35 - 20.00		3	127	L ₁ = 1.5-3 x Ø 		✓	✓	
DIXI 7203 Ø 2.00 - 20.00		3	129	L ₁ = 2-4 x Ø		✓	✓	
DIXI 7223 Ø 3.00 - 20.00		3	130	L ₁ = 3-10 x Ø		✓	✓	✓
DIXI 7333 Ø 0.30 - 10.00		3	131	L ₁ = 1 x Ø		✓	✓	
DIXI 7333-3D Ø 0.30 - 4.00		3	132	L ₁ = 1 x Ø L ₂ = 3 x Ø		✓	✓	
DIXI 7333-5D Ø 0.30 - 3.00		3	132	L ₁ = 1 x Ø L ₂ = 5 x Ø		✓	✓	



○ bien ⊙ excellent

Acier + Pb	Acier faibl. allié	Aciers fort. allié	Acier inox aust.	Aciers Fontes 45-65 HRC	Fontes	Super alliages Ni / Co	Titane, alliages de titane	Alliage Cu Argent Or	Alliage Cu difficile	Alu	Graphite	Plastique
------------	--------------------	--------------------	------------------	-------------------------	--------	------------------------	----------------------------	----------------------	----------------------	-----	----------	-----------

⊙	○	○	○		⊙	○	⊙	⊙	⊙	○		○
⊙	○	○	○		⊙	○	⊙	⊙	⊙	○		○
⊙	○	○	○		⊙	○	⊙	⊙	⊙	○		○
○					○		⊙	○	○	⊙		○
○					○		⊙	○	○	⊙		○
○								○	○	⊙	⊙	○
⊙	○				○			⊙		⊙		○

⊙	○	○	○		⊙		○	⊙	○	⊙		○
⊙	○	○	○		⊙		○	⊙	○	⊙		○
⊙	○	○	○		⊙		○	⊙	○	⊙	⊙	○
⊙	○	○	⊙		⊙	○	⊙	⊙	⊙	○		○
⊙	○	○	⊙		⊙	○	⊙	⊙	⊙	○		○
⊙	○	○	⊙		⊙	○	⊙	⊙	⊙	○		○



SELECTION DES FRAISES

✓ = article de stock

FRAISES EN BOUT Z=3		Z	Page		<input type="checkbox"/> CARBURE	<input type="checkbox"/> TiAIN	<input type="checkbox"/> CUTINOX	<input type="checkbox"/> XIDUR	<input type="checkbox"/> DAC	<input type="checkbox"/> DIAMANT
DIXI 7333-8D Ø 0.30 - 3.00		3	132	L ₁ = 1 x Ø L ₂ = 8 x Ø		✓	✓			
DIXI 7543 Ø 1.00 - 12.00		3	134	L ₁ = 1 - 2 x Ø				✓		
DIXI 7583 Ø 0.30 - 6.00		3	135	L ₁ = 2 x Ø		✓	✓			
DIXI 7253 Ø 3.00 - 20.00		3	136	L ₁ = 1 x Ø L ₂ = 3 x Ø			✓			
DIXI 7273 Ø 3.00 - 20.00		3	136	L ₁ = 1.5-3.5 x Ø		✓	✓			
DIXI 7593 Ø 6.00 - 20.00		3	137	L ₁ = 1 x Ø L ₂ = 4-5.5 x Ø		✓				
DIXI 7210 Ø 3.00 - 12.00		3	137	L ₁ = 2 x Ø		✓	✓			
DIXI 7213 Ø 4.00 - 20.00		3	138	L ₁ = 1.5-2.5 x Ø		✓	✓			
DIXI 7215 Ø 6.00 - 16.00		3	138	L ₁ = 2 x Ø					✓	
FRAISES EN BOUT Z=4										
DIXI 7244 Ø 0.40 - 20.00		4	139	L ₁ = 2-3.5 x Ø 		✓	✓			✓
DIXI 7204 Ø 2.00 - 6.00		4	140	L ₁ = 2.5-4 x Ø		✓	✓			
DIXI 7224 Ø 3.00 - 20.00		4	140	L ₁ = 3-10 x Ø		✓	✓			✓
DIXI 7264 Ø 1.50 - 20.00		4	141	L ₁ = 2-3 x Ø 			✓			



○ bien ⊙ excellent

Acier + Pb	Acier faibl. allié	Aciers fort. allié	Acier inox aust.	Aciers Fontes 45-65 HRC	Fontes	Super alliages Ni / Co	Titane, alliages de titane	Alliage Cu Argent Or	Alliage Cu difficile	Alu	Graphite	Plastique
------------	--------------------	--------------------	------------------	-------------------------	--------	------------------------	----------------------------	----------------------	----------------------	-----	----------	-----------

⊙	○	○	⊙		⊙	○	⊙	⊙	⊙	○		○
⊙	○	○	○		○		○					
○	○	○	⊙		○		⊙	○	⊙	○		○
○	⊙	⊙	⊙		○	⊙	⊙					
⊙	○				○		○	○	○	⊙		○
										⊙		
⊙	⊙	○	⊙		○		⊙	○	○	⊙		
⊙	○	○	○		○		○	○	○	○		
								○		⊙		

⊙	○	○	○		⊙		○	⊙	○	⊙	⊙	○
⊙	○	○	○		⊙		○	⊙	○	⊙		○
⊙	○				○		○	⊙	○	⊙	⊙	○
○	⊙	⊙	⊙		○	⊙	⊙					



SELECTION DES FRAISES

✓ = article de stock

FRAISES EN BOUT Z=4		Z	Page			<input type="checkbox"/> CARBURE	<input type="checkbox"/> TiAIN	<input type="checkbox"/> CUTINOX	<input type="checkbox"/> DICUT	<input type="checkbox"/> XIDUR	<input type="checkbox"/> DLC
DIXI 7264 3-D Ø 6.00 - 20.00		4	141	L ₁ = 2 x Ø L ₂ = 3 x Ø				✓			
DIXI 7254 Ø 3.00 - 20.00		4	142	L ₁ = 1-1.5 x Ø L ₂ = 3 x Ø				✓			
DIXI 7214 Ø 6.00 - 20.00		4	142	L ₁ = 2-2.5 x Ø		✓	✓				
FRAISES MULTIDENTS											
DIXI 7560 Ø 0.35 - 20.00		3-8	143	L ₁ = 2-4 x Ø		✓	✓				✓
DIXI 7520 Ø 0.40 - 16.00		3-10	144	L ₁ = 2 x Ø						✓	
FRAISES HAUTE AVANCE											
DIXI 7702 Ø 0.50 - 12.00		2	145	L ₂ = 3 x Ø						✓	
FRAISES TORIQUES											
DIXI 7237-10 Ø 0.40 - 3.00		2	146	L ₁ = 1 x Ø L ₂ = 3 x Ø		✓	✓				
DIXI 7070 Ø 3.00 - 12.00		4-6	147	L ₁ = 1-1.5 x Ø L ₂ = 2.5-4 x Ø						✓	
DIXI 7265 Ø 2.00 - 12.00		4	148	L ₁ = 2 x Ø				✓			
DIXI 7554 Ø 2.00 - 12.00		4	149	L ₁ = 1-1.5 x Ø L ₂ = 3-5 x Ø		✓	✓				
DIXI 7552 Ø 3.00 - 16.00		2	150	L ₁ = 1-1.5 x Ø L ₂ = 2.5-3.5 x Ø		✓			✓		



○ bien ⊙ excellent

Acier + Pb	Acier faibl. allié	Aciers fort. allié	Acier inox aust.	Aciers Fontes 45-65 HRC	Fontes	Super alliages Ni / Co	Titane, alliages de titane	Alliage Cu Argent Or	Alliage Cu difficile	Alu	Graphite	Plastique
------------	--------------------	--------------------	------------------	-------------------------	--------	------------------------	----------------------------	----------------------	----------------------	-----	----------	-----------

○	⊙	⊙	⊙		○	⊙	⊙					
○	⊙	⊙	⊙		○	⊙	⊙					
⊙	○	○	○		⊙		○	○	○	○		

⊙	⊙	○	⊙		⊙	○	○	⊙	⊙			
		○		⊙		○						

⊙	⊙	⊙	⊙	⊙	⊙	⊙	⊙	⊙	⊙	○	○	
---	---	---	---	---	---	---	---	---	---	---	---	--

⊙	○	○	○		⊙	○	⊙	⊙	⊙	○		○
		○		⊙		○						
⊙	○	○	○		⊙		⊙	○	○	○		○
⊙	○	○	○		⊙		⊙	○	○	○		○
○	○				○		⊙	○	⊙	○		○



SELECTION DES FRAISES

✓ = article de stock

FRAISES HÉMISPHERIQUES				Z	Page		<input type="checkbox"/> CARBURE	<input type="checkbox"/> TITAIN	<input type="checkbox"/> DICUT	<input type="checkbox"/> XIDUR	<input type="checkbox"/> DIAMANT
DIXI 7032 Ø 0.06 - 20.00		30°		2	151	$L_1 = 1.5-2 \times \emptyset$	✓	✓	✓		✓
DIXI 7042 Ø 2.00 - 20.00		30°		2	152	$L_1 = 2-5 \times \emptyset$	✓	✓			✓
DIXI 7046 Ø 0.20 - 12.00		30°		2	153	$L_1 = 1-2.5 \times \emptyset$ $L_2 = 2.5-6 \times \emptyset$	✓	✓	✓		✓
DIXI 7045 Ø 0.20 - 12.00		30°		2	154	$L_1 = 1-2.5 \times \emptyset$ $L_2 = 2.5-6 \times \emptyset$	✓	✓	✓		✓
DIXI 7047-8D Ø 0.20 - 12.00		30°		2	154	$L_1 = 1-2.5 \times \emptyset$ $L_2 = 8 \times \emptyset$	✓	✓	✓		✓
DIXI 7047-10D Ø 0.20 - 12.00		30°		2	154	$L_1 = 1-2.5 \times \emptyset$ $L_2 = 10 \times \emptyset$	✓	✓	✓		✓
DIXI 7047-12D Ø 0.20 - 5.00		30°		2	154	$L_1 = 1-2.5 \times \emptyset$ $L_2 = 12 \times \emptyset$	✓	✓	✓		✓
DIXI 7047-15D Ø 0.20 - 4.00		30°		2	154	$L_1 = 1-2.5 \times \emptyset$ $L_2 = 15 \times \emptyset$	✓	✓	✓		✓
DIXI 7047-18D Ø 0.20 - 3.00		30°		2	154	$L_1 = 1-2.5 \times \emptyset$ $L_2 = 18 \times \emptyset$	✓	✓	✓		✓
DIXI 7532 Ø 0.20 - 10.00		30°		2	156	$L_1 = 1 \times \emptyset$				✓	
DIXI 7532-3D Ø 0.20 - 10.00		30°		2	157	$L_1 = 1 \times \emptyset$ $L_2 = 3 \times \emptyset$				✓	
DIXI 7532-5D Ø 0.20 - 10.00		30°		2	157	$L_1 = 1 \times \emptyset$ $L_2 = 5 \times \emptyset$				✓	
DIXI 7532-8D Ø 0.20 - 4.00		30°		2	157	$L_1 = 1 \times \emptyset$ $L_2 = 8 \times \emptyset$				✓	



○ bien ⊙ excellent

Acier + Pb	Acier faibl. allié	Aciers fort. allié	Acier inox aust.	Aciers Fontes 45-65 HRC	Fontes	Super alliages Ni / Co	Titane, alliages de titane	Alliage Cu Argent Or	Alliage Cu difficile	Alu	Graphite	Plastique
------------	--------------------	--------------------	------------------	-------------------------	--------	------------------------	----------------------------	----------------------	----------------------	-----	----------	-----------

⊙	○	○	○		⊙	○	○	⊙	○	⊙	⊙	⊙
⊙	○	○	○		⊙	○	○	⊙	○	⊙	⊙	⊙
⊙	⊙	⊙	⊙		○	○	⊙	○	⊙	○	⊙	○
⊙	⊙	⊙	⊙		○	○	⊙	○	⊙	○	⊙	○
⊙	⊙	⊙	⊙		○	○	⊙	○	⊙	○	⊙	○
⊙	⊙	⊙	⊙		○	○	⊙	○	⊙	○	⊙	○
⊙	⊙	⊙	⊙		○	○	⊙	○	⊙	○	⊙	○
⊙	⊙	⊙	⊙		○	○	⊙	○	⊙	○	⊙	○
⊙	⊙	⊙	⊙		○	○	⊙	○	⊙	○	⊙	○
		○		⊙		○						
		○		⊙		○						
		○		⊙		○						
		○		⊙		○						



SELECTION DES FRAISES

✓ = article de stock

FRAISES HÉMISPHERIQUES		Z	Page			CARBURE	TiAIN	XIDUR	PCD	DIA
DIXI 7532-10D Ø 0.40 - 3.00		2	157	$L_1 = 1 \times \emptyset$ $L_2 = 10 \times \emptyset$				✓		
DIXI 7532-12D Ø 0.50 - 2.00		2	157	$L_1 = 1 \times \emptyset$ $L_2 = 12 \times \emptyset$				✓		
DIXI 7532-15D Ø 0.60 - 2.00		2	157	$L_1 = 1 \times \emptyset$ $L_2 = 15 \times \emptyset$				✓		
DIXI 7542 Ø 1.00 - 12.00		2	158	$L_1 = 1.5-2 \times \emptyset$ $L_2 = 3 \times \emptyset$				✓		
DIXI 7033 Ø 1.00 - 12.00		3	159	$L_1 = 1.5-2 \times \emptyset$		✓	✓			
DIXI 7034 Ø 6.00 - 20.00		4	159	$L_1 = 1.5 \times \emptyset$		✓	✓			
FRAISES DIAMANT										
DIXI 72420 PCD Ø 1.00 - 20.00		1 - 2	160	$L_1 = 1-1.5 \times \emptyset$ $L_2 = 1.5-6 \times \emptyset$					✓	
DIXI 70520 PCD Ø 1.00 - 20.00		1 - 2	161	$L_1 = 1-1.5 \times \emptyset$ $L_2 = 1.5-6 \times \emptyset$					✓	
DIXI 70600 PCD Ø 1.00 - 6.00		1	162	$L_1 = 1.5 \times \emptyset$					✓	
DIXI 70600 DIA Ø 3.00 - 6.00		1	162	$L_1 = 2 \times \emptyset$						✓
DIXI 72310 DIA Ø 0.30 - 2.00		1	163	$L_1 = 1-2.5 \times \emptyset$						✓



○ bien ⊙ excellent

Acier + Pb	Acier faibl. allié	Aciers fort. allié	Acier inox aust.	Aciers Fontes 45-65 HRC	Fontes	Super alliages Ni / Co	Titane, alliages de titane	Alliage Cu Argent Or	Alliage Cu difficile	Alu	Graphite	Plastique
------------	--------------------	--------------------	------------------	-------------------------	--------	------------------------	----------------------------	----------------------	----------------------	-----	----------	-----------











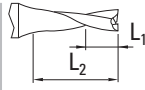

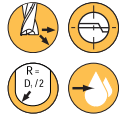

		○		⊙		○						
		○		⊙		○						
		○		⊙		○						
		○		⊙		○						
⊙	⊙	⊙	○		⊙	○	○	⊙		⊙		⊙
⊙	⊙	⊙	○		⊙	○	○	○	○	○		○

								⊙	⊙	⊙	⊙	⊙
								⊙	⊙	⊙	⊙	⊙
								⊙	⊙	⊙	⊙	⊙
								⊙	○	⊙		⊙
								⊙	○	⊙		⊙

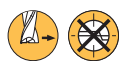

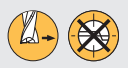
SELECTION DES FRAISES

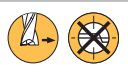
✓ = article de stock

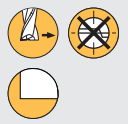
	Z	Page			<input type="checkbox"/> CARBURE	<input checked="" type="checkbox"/> TITAIN	<input checked="" type="checkbox"/> PCD	<input checked="" type="checkbox"/> DIA
FRAISES DIAMANT								
DIXI 72421 DIA Ø 6.00 - 12.00 	1	164						✓
DIXI 70320 PCD Ø 2.00 - 20.00 	1 - 2	165	$L_1 = 0.5-1 \times \varnothing$ $L_2 = 1.5-6 \times \varnothing$				✓	
DIXI 76230 DIA Ø 0.10 - 0.30 	1	166						✓
FRAISES À CHANFREINER ET RAYONNER								
DIXI 7623 Ø 0.80 - 12.00 	3	166			✓	✓		
DIXI 7624 Ø 0.20 - 5.70 	1 - 4	167			✓			
DIXI 7656 R 0.10 - 1.00 	2	168			✓	✓		
FRAISES POUR COMPOSITES / KEVLAR®								
DIXI 7112 Ø 5.00 - 12.70 	2	168	$L_1 = 2 - 4 \times \varnothing$		✓			



○ bien ⊙ excellent

Acier + Pb	Acier faibl. allié	Aciers fort. allié	Acier inox aust.	Aciers Fontes 45-65 HRC	Fontes	Super alliages Ni / Co	Titane, alliages de titane	Alliage Cu Argent Or	Alliage Cu difficile	Alu	Graphite	Plastique
------------	--------------------	--------------------	------------------	-------------------------	--------	------------------------	----------------------------	----------------------	----------------------	-----	----------	-----------

												⊙
								⊙	⊙	⊙	⊙	⊙
								⊙	○	⊙		⊙

⊙	○	○	○		⊙	○	⊙	⊙	⊙	⊙		⊙
⊙	○	○	○		⊙	○	⊙	⊙	⊙	⊙		⊙
⊙	○	○	○		⊙	○	⊙	⊙	⊙	⊙		⊙

Kevlar®

												⊙
--	--	--	--	--	--	--	--	--	--	--	--	---



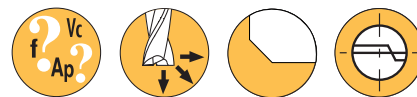

P. 212

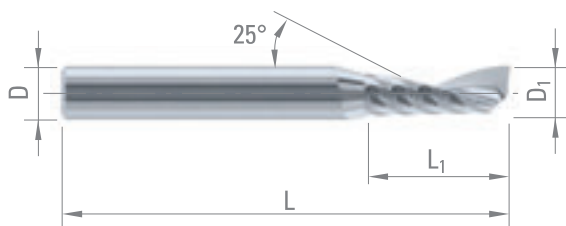

Alliage Cu
Argent
Or

Alu

Plastique

D_1 e8		L_1	D_{h5}	L	CARBURE
2.00	0.10 x 45°	4.0	3	38	46560
3.00	0.15 x 45°	6.0	3	38	46561
4.00	0.15 x 45°	12.0	4	50	46562
5.00	0.15 x 45°	14.0	5	50	46563
6.00	0.20 x 45°	16.0	6	50	46564
8.00	0.20 x 45°	20.0	8	60	46565
10.00	0.20 x 45°	22.0	10	70	46566
12.00	0.20 x 45°	25.0	12	70	46567

DIXI 7301

FRAISES 1 DENT - COURTES

Z = 1

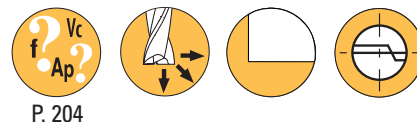

P. 204

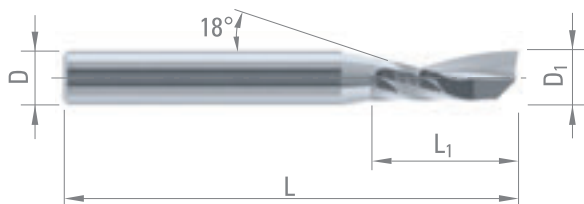

Plastique

$D_{1\ e8}$	L_1	D_{h5}	L	CARBURE
2.00	6.0	3	38	965241
3.00	12.0	3	50	963955
4.00	16.0	4	50	964011
5.00	16.0	5	50	964012
6.00	16.0	6	50	964014
8.00	23.0	8	50	964016

DIXI 7302

FRAISES 1 DENT - LONGUES

Z = 1

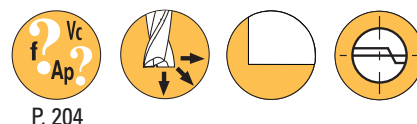

P. 204

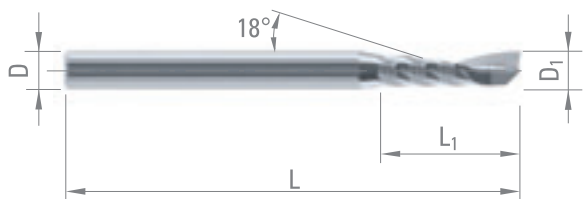

Plastique

$D_{1\ e8}$	L_1	D_{h5}	L	CARBURE
3.00	17.0	3	61	963956
4.00	23.0	4	61	964031
5.00	23.0	5	61	964032
6.00	23.0	6	75	964033
8.00	32.0	8	75	964034
10.00	33.0	10	75	964093
12.00	33.0	12	100	964094



FRAISES 1 DENT - LONGUES
CORPS RENFORCÉ

Z = 1

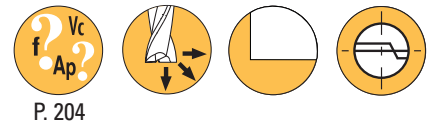

P. 204

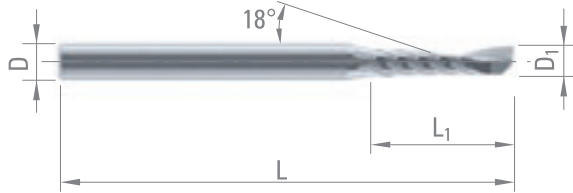

Plastique

$D_{1\ e8}$	L_1	D_{h5}	L	CARBURE
2.00	8.0	6	50	964147
3.00	18.0	6	75	963957
4.00	23.0	6	75	964079
5.00	23.0	6	75	964084



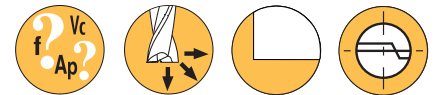

P. 202

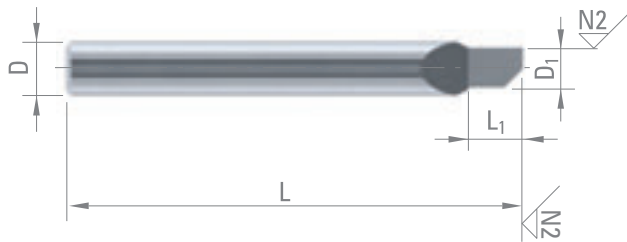

- Acier + Pb
- Fontes
- Alliage Cu Argent Or
- Alliage Cu difficile
- Alu
- Plastique

$D_{1 \pm 0.01}$	L_1	D_{h5}	L	CARBURE
0.50	1.0	4	35	965456
0.60	1.2	4	35	965457
0.70	1.5	4	35	965458
0.80	1.5	4	35	960645
0.90	1.5	4	35	960646
1.00	1.5	4	35	960647
1.00 >	2.5	4	35	964328
1.10	2.0	4	35	960648
1.20	2.0	4	35	960649
1.30	2.0	4	35	960650
1.40	2.0	4	35	960651
1.50	2.0	4	35	960652
1.60	2.0	4	35	960653
1.70	2.5	4	35	960654
1.80	2.5	4	35	960655
1.90	2.5	4	35	960656
2.00	2.5	4	35	960657
2.50	3.0	4	35	960658
3.00	3.5	4	42	960659
3.50	4.0	4	42	960660
4.00	5.0	4	42	960661
4.50	6.0	6	50	960662
5.00	7.0	6	50	960663
6.00	7.0	8	50	960664



DIXI 7063

FRAISES 1 DENT 3/4

Z = 1



P. 202

$\emptyset 0.40 \leq \emptyset 1.80$



$\emptyset 1.80 \leq \emptyset 4.00$

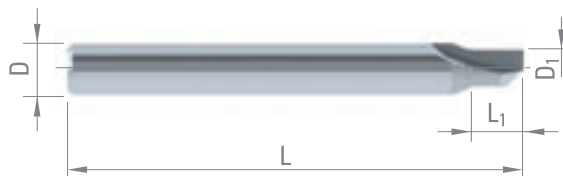

Alliage Cu
Argent
Or

Alliage
Cu
difficile

Alu

Plastique

$D_{1 \pm 0.01}$	L_1	D_2	L_2	D_{h5}	L	CARBURE
0.40	0.8	1.5	4.6	4	35	987593
0.50	1.0	1.5	4.6	4	35	983250
0.60	1.2	1.5	4.6	4	35	987594
0.70	1.5	1.5	4.6	4	35	987595
0.80	1.5	1.5	4.6	4	35	987596
0.90	1.5	2.0	5.1	4	35	987581
1.00	1.5	2.0	5.1	4	35	983251
1.00 >	2.5	2.0	5.1	4	35	987582
1.10	2.5	2.0	6.0	4	35	987597
1.20	2.5	2.0	6.0	4	35	987598
1.30	2.5	3.0	6.0	4	35	987599
1.40	2.5	3.0	6.0	4	35	987583
1.50	2.5	3.0	6.0	4	35	983252
1.50 >	3.5	3.0	6.5	4	35	987600
1.60	3.5	3.0	6.5	4	35	987585
1.70	3.5	3.0	6.5	4	35	987586

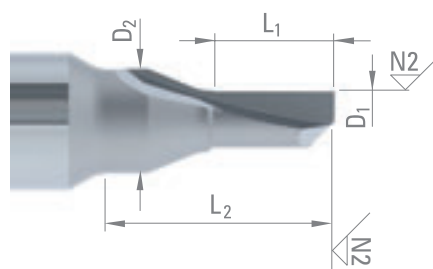

$D_{1 \pm 0.01}$	L_1	D_{h5}	L	CARBURE
1.80	3.5	4	35	987601
1.90	3.5	4	35	987602
2.00	4.0	4	35	983253
2.20	4.0	4	35	987603
2.50	4.0	4	35	987604
2.80	4.0	4	35	987605
3.00	4.0	4	35	983254
4.00	5.0	4	35	987584

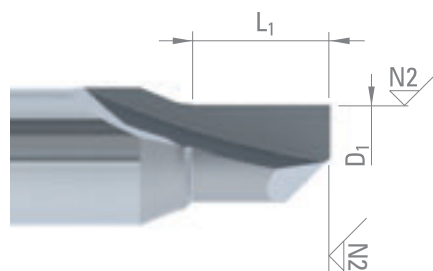

DIXI 7242

FRAISES EN BOUT HÉLICOÏDALES CORPS RENFORCÉ

Z = 2



P. 180



$D_1 > 6$

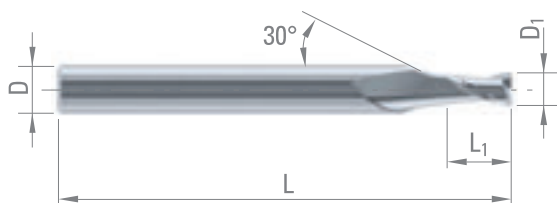

Acier + Pb	Acier faibl. allié	Acier fort. allié	Acier inox aust.	Fontes
Titane, alliage de titane	Alliage Cu Argent Or	Alliage Cu difficile	Alu	Plastique

D_1	L_1	D_{h5}	L	CARBURE	TiAIN
$\emptyset < 2.00 - 0/-0.01$					
$\emptyset < 3.00 - 0/-0.02$					
$\emptyset \geq 3.00 - e8$					
0.15	0.3	3	38	52628	64920
0.20	0.4	3	38	45705	60021
0.25	0.6	3	38	47916	64921
0.30	0.6	3	38	42172	60121
0.30 >	1.0	3	38	48850	60122
0.35	0.8	3	38	47917	950699
0.40	0.8	3	38	42126	60123
0.40 >	2.0	3	38	48851	60124
0.45	1.0	3	38	47918	952421
0.50	1.0	3	38	35241	36230
0.50 >	2.5	3	38	48852	60125
0.55	1.2	3	38	47921	952422
0.60	1.2	3	38	35242	36231
0.60 >	3.0	3	38	48853	60126
0.65	1.4	3	38	47922	952423
0.70	1.4	3	38	35243	36232
0.70 >	3.5	3	38	48854	57162
0.75	1.6	3	38	47923	57163
0.80	1.6	3	38	35244	36233
0.80 >	4.0	3	38	48855	57164
0.85	1.8	3	38	47066	57165
0.90	1.8	3	38	35245	36234
0.90 >	4.5	3	38	48856	57166
0.95	2.0	3	38	42846	57167
1.00	2.0	3	38	35246	36235
1.00 >	5.0	3	38	42735	55950
1.05	2.2	3	38	47924	57168
1.10	2.2	3	38	35247	57169
1.15	2.4	3	38	47925	57170
1.20	2.4	3	38	35248	36237
1.20 >	6.0	3	38	48857	57171
1.25	2.6	3	38	47926	57172
1.30	2.6	3	38	35249	57173
1.35	2.8	3	38	47927	57174
1.40	2.8	3	38	35250	36239
1.45	3.0	3	38	47928	57175
1.50	3.0	3	38	38489	36240
1.50 >	7.0	3	38	48858	57176



DIXI 7242



P. 180



$D_1 > 6$



D_1 $\emptyset < 2.00 - 0/-0.01$ $\emptyset < 3.00 - 0/-0.02$ $\emptyset \geq 3.00 - e8$	L_1	D_{h5}	L	CARBURE	TiAIN
1.60	3.2	3	38	38490	57177
1.70	3.4	3	38	38491	44939
1.80	3.6	3	38	42096	38613
1.90	4.0	3	38	38493	57178
2.00	6.0	3	38	42784	39577
2.10	7.0	3	38	44058	64794
2.20	7.0	3	38	43956	64795
2.30	7.0	3	38	44877	60627
2.40	7.0	3	38	43527	64796
2.50	7.0	3	38	42201	36242
3.00	7.0	6	57	41806	46440
3.50	7.0	6	57	43353	57179
4.00	8.0	6	57	41856	57180
4.50	8.0	6	57	42202	57181
5.00	10.0	6	57	41996	36247
5.50	10.0	6	57	41807	57182
6.00	10.0	6	57	41907	57183
6.50	13.0	8	63	28932	57184
7.00	13.0	8	63	28933	57185
7.50	16.0	8	63	28934	57186
8.00	16.0	8	63	42271	57187
8.50	16.0	10	72	28936	57195
9.00	16.0	10	72	28937	57196
9.50	19.0	10	72	43038	57197
10.00	19.0	10	72	42352	57198
12.00	22.0	12	83	39944	57199
14.00	22.0	14	83	42353	57200
16.00	26.0	16	92	42354	57201
18.00	26.0	18	92	42355	57202
20.00	32.0	20	104	42356	57203

Acier + Pb	Acier faibl. allié	Acier fort. allié	Acier inox aust.	Fontes
Titane, alliage de titane	Alliage Cu Argent Or	Alliage Cu difficile	Alu	Plastique

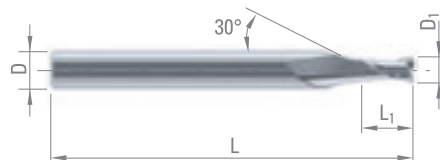

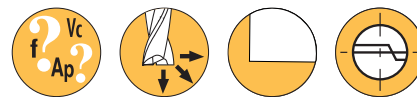

P. 180

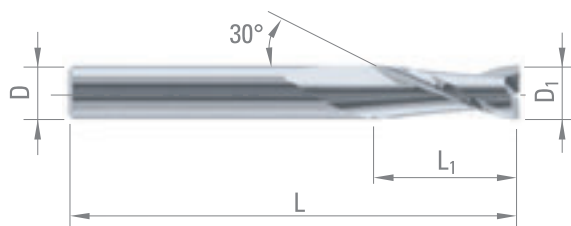

Acier + Pb	Acier faibl. allié	Acier inox aust.	Titane, alliage de titane	Alliage Cu Argent Or
Alliage Cu difficile	Alu	Graphite	Plastique	

D_1 e8 $\emptyset < 2.00 - 0/-0.01$ $\emptyset \geq 2.00 - e8$	L_1	D_{h5}	L	CARBURE	TiAlN	DIAMANT
1.50	6	2.0	32	690	57063	
2.00	8	2.0	32	691	57064	61616
2.50	8	2.5	32	692	57065	
3.00	10	3.0	38	693	57066	36199
3.50	12	3.5	38	34760	57067	
4.00	12	4.0	50	694	57068	63847
4.50	12	4.5	50	41135	57069	
5.00	14	5.0	50	34623	57070	
6.00	16	6.0	50	34624	57071	62991
7.00	18	7.0	60	29769	57072	
8.00	20	8.0	63	698	57073	67513
9.00	20	9.0	67	43726		
10.00	22	10.0	72	699	57075	
11.00	22	11.0	73	28686		
12.00	22	12.0	73	30940	57077	
13.00	25	13.0	75	30941		
14.00	25	14.0	75	27069		
15.00	25	15.0	75	28901		
16.00	27	16.0	82	27070		



FRAISES EN BOUT HÉLICOÏDALES
LONGUES

Z = 2

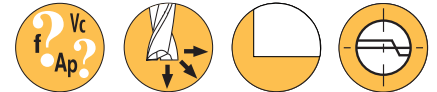

P. 196

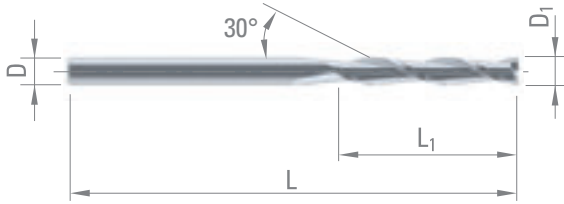

Acier + Pb	Acier faibl. allié	Acier inox aust.	Titane, alliage de titane	Alliage Cu Argent Or
Alliage Cu difficile	Alu	Graphite	Plastique	

D _{1 e8}	L ₁	D _{h5}	L	CARBURE	TiAlN	DIAMANT
3.00	30.0	3	60	44756	57124	60231
4.00	30.0	4	60	44757	57125	60232
5.00	35.0	5	75	44758	57133	60233
6.00	40.0	6	100	44759	57134	60234
8.00	40.0	8	100	44760	57135	60235
10.00	40.0	10	100	44761	57136	60236
12.00	45.0	12	100	44762	57137	60237
16.00	65.0	16	150	44764	57139	
20.00	65.0	20	150	44766	57140	



DIXI 7240

FRAISES EN BOUT EXTRA COURTES CORPS RENFORCÉ

Z = 2



P. 180

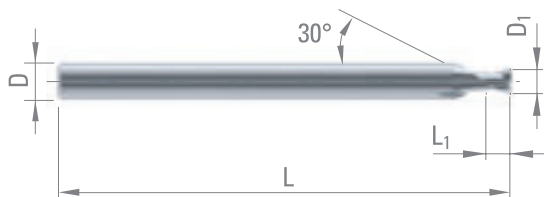

Acier + Pb	Acier faibl. allié	Acier fort. allié	Acier inox aust.	Fontes
Super alliages Ni / Co	Titane, alliage de titane	Alliage Cu Argent Or	Alliage Cu difficile	Alu
Plastique				

D ₁	L ₁	D _{h5}	L	CARBURE	TiAIN
Ø < 2.00 - 0/-0.01					
Ø < 3.00 - 0/-0.02					
Ø ≥ 3.00 - e8					
0.04	0.04	3	38	954084	
0.05	0.05	3	38	954085	
0.06	0.06	3	38	951973	
0.07	0.07	3	38	954087	
0.08	0.08	3	38	954086	
0.09	0.09	3	38	954089	
0.10	0.10	3	38	63609	64354
0.12	0.12	3	38	954090	956316
0.15	0.15	3	38	63608	64355
0.20	0.20	3	38	63610	64356
0.25	0.25	3	38	63678	64357
0.30	0.30	3	38	63679	64253
0.35	0.35	3	38	63680	64358
0.40	0.40	3	38	56551	61443
0.45	0.45	3	38	63681	64359
0.50	0.50	3	38	63682	64254
0.55	0.55	3	38	63683	64360
0.60	0.60	3	38	45571	64361
0.65	0.65	3	38	63684	64362
0.70	0.70	3	38	63685	64363
0.75	0.75	3	38	63686	64364
0.80	0.80	3	38	63687	64255
0.85	0.85	3	38	63688	64365
0.90	0.90	3	38	63689	62538
0.95	0.95	3	38	63690	64366
1.00	1.00	3	38	50547	64367
1.05	1.05	3	38	63691	64368
1.10	1.10	3	38	63692	64369
1.15	1.15	3	38	63805	64370
1.20	1.20	3	38	63806	64371
1.25	1.25	3	38	63807	64372
1.30	1.30	3	38	63808	64373
1.35	1.35	3	38	63809	64374
1.40	1.40	3	38	63810	64375
1.45	1.45	3	38	63811	64376
1.50	1.50	3	38	50548	56840
1.55	1.55	3	38	63812	64377
1.60	1.60	3	38	63813	64378
1.65	1.65	3	38	63814	64379
1.70	1.70	3	38	63815	64380
1.75	1.75	3	38	63816	64381



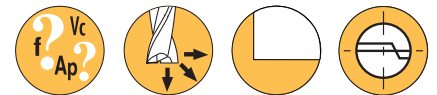

P. 180

D_1 $\emptyset < 2.00 - 0/-0.01$ $\emptyset < 3.00 - 0/-0.02$ $\emptyset \geq 3.00 - e8$	L_1	D_{h5}	L	CARBURE	TIAIN
1.80	1.80	3	38	63817	64382
1.85	1.85	3	38	63818	64383
1.90	1.90	3	38	63819	64384
1.95	1.95	3	38	63820	64385
2.00	2.00	6	50	63821	64386
2.10	2.10	6	50	63823	64387
2.20	2.20	6	50	63824	64388
2.30	2.30	6	50	63825	64389
2.40	2.40	6	50	63826	64390
2.50	2.50	6	50	63827	64391
3.00	3.00	6	50	63828	64392
3.50	3.50	6	50	63829	64393
4.00	4.00	6	50	63830	64394
4.50	4.50	6	50	63831	64395
5.00	5.00	6	50	63832	64397
5.50	5.50	6	50	63833	64398

Acier + Pb	Acier faibl. allié	Acier fort. allié	Acier inox aust.	Fontes
Super alliages Ni / Co	Titane, alliage de titane	Alliage Cu Argent Or	Alliage Cu difficile	Alu
Plastique				

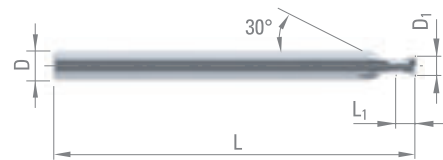

DIXI 7237 - 7238 - 7239 - 7239-D

FRAISES EN BOUT EXTRA COURTES, DÉGAGÉES

Z = 2

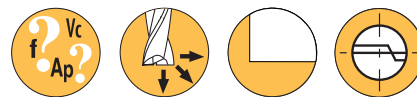

P. 180
P. 182

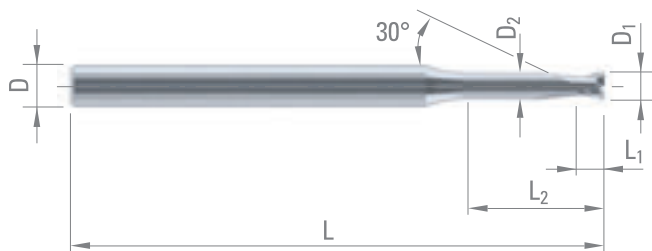

Acier + Pb	Acier faibl. allié	Acier fort. allié	Acier inox aust.	Fontes
Super alliages Ni / Co	Titane, alliage de titane	Alliage Cu Argent Or	Alliage Cu difficile	Alu
Plastique				

D₁ L₁ D₂ D_{h5} L L₂ DIXI CARBURE TiAIN

∅ < 2.00 - 0/-0.01
∅ < 3.00 - 0/-0.02
∅ ≥ 3.00 - e8

D ₁	L ₁	D ₂	D _{h5}	L	L ₂	DIXI	CARBURE	TiAIN
0.15	0.15	0.13	3	38	0.45	7237	66047	66149
0.20	0.20	0.17	3	38	0.60	7237	66068	66150
0.25	0.25	0.22	3	38	0.75	7237	66070	66151
0.30	0.30	0.27	3	38	0.90	7237	66071	66152
					1.50	7238	66196	66254
0.35	0.35	0.32	3	38	1.05	7237	66072	66153
					1.75	7238	66197	66255
0.40	0.40	0.37	3	38	1.20	7237	66073	66154
					2.00	7238	66199	66256
					3.20	7239	66296	66355
					1.35	7237	66074	66155
0.45	0.45	0.42	3	38	2.25	7238	66201	66257
					3.60	7239	66297	66356
					1.50	7237	66075	66156
					2.50	7238	66202	66258
0.50	0.50	0.45	3	38	4.00	7239	66298	66357
					5.00	7239-10D	978569	979371
					6.00	7239-12D	979313	979447
					7.50	7239-15D	979475	979497
					1.65	7237	66076	66157
0.55	0.55	0.50	3	38	2.75	7238	66203	66259
					4.40	7239	66299	66358
					5.50	7239-10D	979332	979373
					6.60	7239-12D	979413	979448
					8.25	7239-15D	979478	979498
0.60	0.60	0.55	3	38	1.80	7237	66077	66158
					3.00	7238	66205	66260
					4.80	7239	66300	66366
					6.00	7239-10D	979333	979374
					7.20	7239-12D	979416	979449
					9.00	7239-15D	979480	979499
0.65	0.65	0.60	3	38	1.95	7237	66078	66159
					3.25	7238	66206	66261
					5.20	7239	66301	66367
					6.50	7239-10D	979334	979375
					7.80	7239-12D	979417	979450
					9.75	7239-15D	979482	979500
0.70	0.70	0.65	3	38	2.10	7237	66079	66160
					3.50	7238	66207	66262
					5.60	7239	66302	66368
					7.00	7239-10D	979335	979376
					8.40	7239-12D	979419	979451
					10.50	7239-15D	979483	979503
0.75	0.75	0.70	3	38	2.25	7237	66080	66161
					3.75	7238	66208	66263
					6.00	7239	66303	66369
					7.50	7239-10D	979336	979377
					9.00	7239-12D	979420	979452
					11.25	7239-15D	979484	979505
0.80	0.80	0.75	3	38	2.40	7237	66081	66162
					4.00	7238	66209	66264
					6.40	7239	66304	66370
					8.00	7239-10D	979337	979378
					9.60	7239-12D	979421	979453
					12.00	7239-15D	979485	979506

DIXI 7237 L₂ = 3 x D₁

DIXI 7238 L₂ = 5 x D₁

DIXI 7239 L₂ = 8 x D₁

DIXI 7239-10D L₂ = 10 x D₁

DIXI 7239-12D L₂ = 12 x D₁

DIXI 7239-15D L₂ = 15 x D₁



DIXI 7237 - 7238 - 7239 - 7239-D

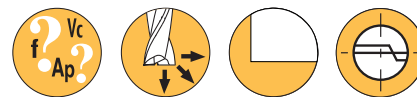

P. 180
P. 182

D ₁	L ₁	D ₂	D _{h5}	L	L ₂	DIXI	CARBURE	TiAIN
0.85	0.85	0.80	3	38	2.55	7237	66082	66164
					4.25	7238	66210	66265
					6.80	7239	66305	66371
					8.50	7239-10D	979338	979409
					10.20	7239-12D	979423	979454
					12.75	7239-15D	979486	979507
					2.70	7237	66083	66165
					4.50	7238	66211	66266
					7.20	7239	66306	66372
					9.00	7239-10D	979339	979379
0.90	0.90	0.85	3	38	10.80	7239-12D	979430	979455
					13.50	7239-15D	979487	979509
					2.85	7237	66084	66166
					4.75	7238	66212	66267
					7.60	7239	66307	66373
					9.50	7239-10D	979340	979380
					11.40	7239-12D	979431	979456
					14.25	7239-15D	979488	979510
					3.00	7237	66110	66167
					5.00	7238	66213	66268
1.00	1.00	0.95	3	38	8.00	7239	66308	66374
					10.00	7239-10D	979341	979381
					12.00	7239-12D	979206	979457
					15.00	7239-15D	979489	979511
					3.15	7237	66113	66168
					5.25	7238	66214	66269
					8.40	7239	66309	66375
					10.50	7239-10D	979342	979382
					12.60	7239-12D	979432	979458
					15.75	7239-15D	979490	979512
1.05	1.05	1.00	3	38	3.30	7237	66115	66169
					5.50	7238	66218	66270
					8.80	7239	66310	66376
					11.00	7239-10D	979343	979383
					13.20	7239-12D	979433	979459
					16.50	7239-15D	979491	979513
					3.45	7237	66116	66170
					5.75	7238	66219	66271
					9.20	7239	66313	66377
					11.50	7239-10D	979344	979384
13.80	7239-12D	979434	979460					
1.10	1.10	1.05	3	38	17.25	7239-15D	979492	979514
					3.60	7237	66117	66171
					6.00	7238	66220	66272
					9.60	7239	66314	66378
					12.00	7239-10D	979345	979385
					14.40	7239-12D	979435	979461
					18.00	7239-15D	979493	979515
					3.75	7237	66118	66172
					6.25	7238	66221	66273
					10.00	7239	66315	66379
12.50	7239-10D	979346	979386					
1.15	1.15	1.10	3	38	15.00	7239-12D	979437	979462
					18.75	7239-15D	979494	979516
					3.90	7237	66119	66173
					6.50	7238	66222	66274
					10.40	7239	66316	66380
					13.00	7239-10D	979347	979387
					15.60	7239-12D	979438	979463
					19.50	7239-15D	979495	979517
					4.05	7237	66120	66174
					6.75	7238	66223	66275
10.80	7239	66317	66381					
1.20	1.20	1.15	3	38	13.50	7239-10D	979348	979388
					16.20	7239-12D	979439	979464
					20.25	7239-15D	979496	979518
					3.75	7237	66118	66172
					6.25	7238	66221	66273
					10.00	7239	66315	66379
					12.50	7239-10D	979346	979386
					15.00	7239-12D	979437	979462
					18.75	7239-15D	979494	979516
					3.90	7237	66119	66173
1.25	1.25	1.20	3	38	6.50	7238	66222	66274
					10.40	7239	66316	66380
					13.00	7239-10D	979347	979387
					15.60	7239-12D	979438	979463
					19.50	7239-15D	979495	979517
					4.05	7237	66120	66174
					6.75	7238	66223	66275
					10.80	7239	66317	66381
					13.50	7239-10D	979348	979388
					16.20	7239-12D	979439	979464
20.25	7239-15D	979496	979518					

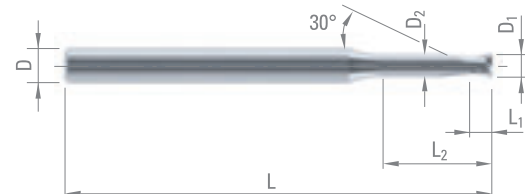

- DIXI 7237** $L_2 = 3 \times D_1$
- DIXI 7238** $L_2 = 5 \times D_1$
- DIXI 7239** $L_2 = 8 \times D_1$
- DIXI 7239-10D** $L_2 = 10 \times D_1$
- DIXI 7239-12D** $L_2 = 12 \times D_1$
- DIXI 7239-15D** $L_2 = 15 \times D_1$

Acier + Pb	Acier faibl. allié	Acier fort. allié	Acier inox aust.	Fontes
Super alliages Ni / Co	Titane, alliage de titane	Alliage Cu Argent Or	Alliage Cu difficile	Alu
Plastique				



DIXI 7237 - 7238 - 7239 - 7239-D

D_1 L_1 D_2 D_{h5} L L_2 **DIXI** **CARBURE** **TiAIN**
 $\emptyset < 2.00 - 0/-0.01$
 $\emptyset < 3.00 - 0/-0.02$
 $\emptyset \geq 3.00 - e8$

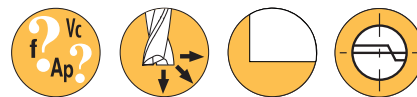

P. 180
P. 182

D_1	L_1	D_2	D_{h5}	L	L_2	DIXI	CARBURE	TiAIN
1.40	1.40	1.35	3	38	4.20	7237	66123	66175
					7.00	7238	66224	66276
					11.20	7239	66318	66382
					14.00	7239-10D	979349	979389
					16.80	7239-12D	979440	979465
1.45	1.45	1.35	3	38	4.35	7237	66124	66176
					7.25	7238	66225	66277
					11.60	7239	66319	66383
					14.50	7239-10D	979350	979390
					17.40	7239-12D	979441	979466
1.50	1.50	1.45	3	38	4.50	7237	66125	66177
					7.50	7238	66226	66278
					12.00	7239	66320	66384
					15.00	7239-10D	979351	979391
					18.00	7239-12D	979442	979467
1.55	1.55	1.50	3	38	4.65	7237	66126	66178
					7.75	7238	66227	66279
					12.40	7239	66323	66385
					15.50	7239-10D	979352	979392
					18.60	7239-12D	979443	979468
1.60	1.60	1.55	3	38	4.80	7237	66127	66179
					8.00	7238	66228	66280
					12.80	7239	66324	66386
					16.00	7239-10D	979353	979393
					19.20	7239-12D	979444	979469
1.65	1.65	1.60	3	38	4.95	7237	66128	66180
					8.25	7238	66229	66281
					13.20	7239	66325	66387
					16.50	7239-10D	979354	979394
					19.80	7239-12D	979445	979470
1.70	1.70	1.65	3	38	5.10	7237	66129	66182
					8.50	7238	66230	66282
					13.60	7239	66326	66388
					17.00	7239-10D	979355	979395
					20.40	7239-12D	979446	979471
1.75	1.75	1.70	3	38	5.25	7237	66130	66183
					8.75	7238	66231	66283
					14.00	7239	66327	66389
					17.50	7239-10D	979356	979396
					1.80	1.80	1.75	3
9.00	7238	66232	66284					
14.40	7239	66328	66390					
18.00	7239-10D	979357	979398					
1.85	1.85	1.80	3	38				
					9.25	7238	66233	66285
					14.80	7239	66329	66391
					18.50	7239-10D	979358	979399
					1.90	1.90	1.85	3
9.50	7238	66234	66286					
15.20	7239	66330	66392					
19.00	7239-10D	979359	979400					
1.95	1.95	1.90	3	38				
					9.75	7238	66235	66287
					15.60	7239	66333	66393
					19.50	7239-10D	979360	979401
					2.00	2.00	1.95	6
10.00	7238	66236	66288					
16.00	7239	66334	66394					
20.00	7239-10D	979361	979402					
2.10	2.10	2.00	6	50				
					10.50	7238	66237	66289
					16.80	7239	66335	66395
					21.00	7239-10D	979362	979403
					2.20	2.20	2.10	6
11.00	7238	66238	66290					
17.60	7239	66350	66396					
22.00	7239-10D	979363	979404					

Acier + Pb	Acier faibl. allié	Acier fort. allié	Acier inox aust.	Fontes
Super alliages Ni / Co	Titane, alliage de titane	Alliage Cu Argent Or	Alliage Cu difficile	Alu
Plastique				

DIXI 7237 $L_2 = 3 \times D_1$

DIXI 7238 $L_2 = 5 \times D_1$

DIXI 7239 $L_2 = 8 \times D_1$

DIXI 7239-10D $L_2 = 10 \times D_1$

DIXI 7239-12D $L_2 = 12 \times D_1$

DIXI 7239-15D $L_2 = 15 \times D_1$

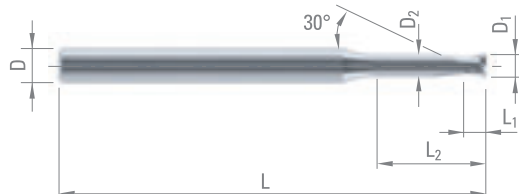

DIXI 7237 - 7238 - 7239 - 7239-D

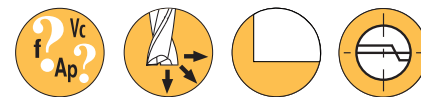

P. 180
P. 182

D ₁	L ₁	D ₂	D _{h5}	L	L ₂	DIXI	CARBURE	TIAIN
Ø < 2.00 - 0/-0.01 Ø < 3.00 - 0/-0.02 Ø ≥ 3.00 - e8								
2.30	2.30	2.20	6	50	6.90	7237	66139	66190
					11.50	7238	66239	66291
					18.40	7239	66351	66397
					23.00	7239-10D	979364	979405
					7.20	7237	66140	66191
2.40	2.40	2.30	6	50	12.00	7238	66240	66292
					19.20	7239	66352	66398
					24.00	7239-10D	979368	979406
					7.50	7237	66143	66192
					12.50	7238	66241	66293
2.50	2.50	2.40	6	50	20.00	7239	66353	66399
					25.00	7239-10D	979369	979407
					9.00	7237	66144	66193
					15.00	7238	66294	66295
					24.00	7239	66354	66400
3.00	3.00	2.90	6	50	30.00	7239-10D	979370	979408

Acier + Pb	Acier faibl. allié	Acier fort. allié	Acier inox aust.	Fontes
Super alliages Ni / Co	Titane, alliage de titane	Alliage Cu Argent Or	Alliage Cu difficile	Alu
Plastique				

DIXI 7237 $L_2 = 3 \times D_1$

DIXI 7238 $L_2 = 5 \times D_1$

DIXI 7239 $L_2 = 8 \times D_1$

DIXI 7239-10D $L_2 = 10 \times D_1$

DIXI 7239-12D $L_2 = 12 \times D_1$

DIXI 7239-15D $L_2 = 15 \times D_1$

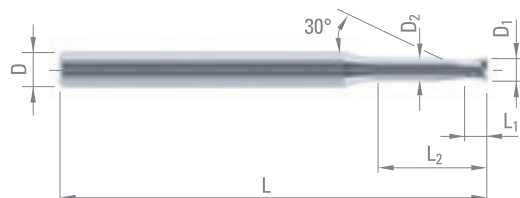

DIXI 7582

FRAISES EN BOUT HÉLICOÏDALES CORPS RENFORCÉ

Z = 2



P. 212



$D_1 \geq 2.8$

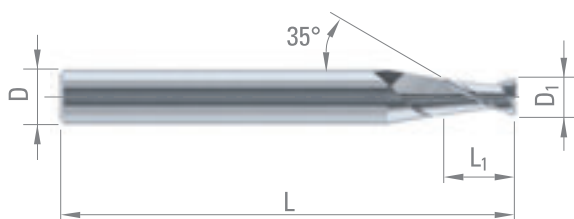

Acier + Pb	Fontes	Titane, alliage de titane	Alliage Cu Argent Or	Alliage Cu difficile
Alu	Plastique			

D_1	L_1	D_{h5}	L	CARBURE	TiAIN
$\emptyset < 2.00 - 0/-0.01$					
$\emptyset < 3.00 - 0/-0.02$					
$\emptyset \geq 3.00 - e8$					

1.00	2.0	3	38	47357	56304
1.50	3.0	3	38	47358	56305
2.00	4.0	4	50	47359	56306
2.50	5.0	4	50	47360	56307
2.80	6.0	6	50	35734	36304
3.00	6.0	6	50	30298	36305
3.80	8.0	6	50	34973	36306
4.00	8.0	6	50	30299	36607
4.50	10.0	6	50	35709	56983
5.00	10.0	6	50	30300	36309
5.50	10.0	6	50	35735	56303

DIXI 7562

FRAISES EN BOUT HÉLICOÏDALES

Z = 2



P. 212

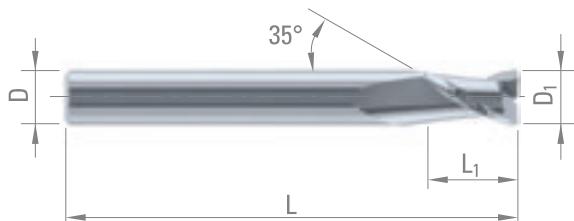

Acier + Pb	Fontes	Titane, alliage de titane	Alliage Cu Argent Or	Alliage Cu difficile
Alu	Plastique			

D_1 e8	L_1	D_{h5}	L	CARBURE	TiAIN
6.00	10.0	6	50	29100	36299
8.00	15.0	8	60	29101	36300
10.00	18.0	10	66	29102	56334
12.00	20.0	12	73	30521	36302
16.00	25.0	16	82	30523	56318
20.00	35.0	20	104	31858	56335



DIXI 7572

FRAISES EN BOUT HÉLICOÏDALES LONGUES

Z = 2

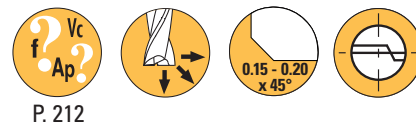

P. 212

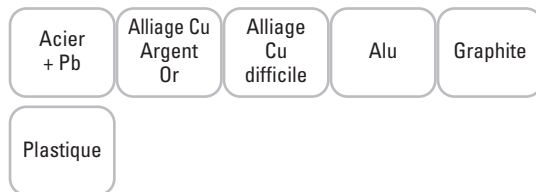
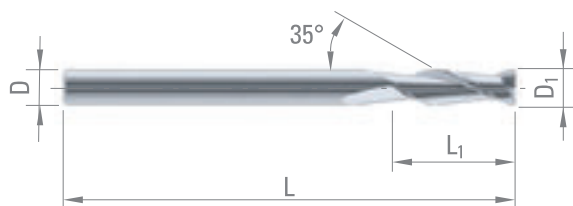

D_1 e8	L_1	D_{h5}	L	CARBURE	TiAIN	DIAMANT
3.00	14.0	3	50	32484	56320	57045
4.00	16.0	4	50	32485	56321	57046
5.00	18.0	5	60	32486	56322	57047
6.00	20.0	6	75	32487	56337	57048
7.00	22.0	7	75	32488		
8.00	25.0	8	75	32489	56336	57050
10.00	30.0	10	90	32491	56341	57052
12.00	36.0	12	100	32492	56342	
16.00	50.0	16	120	32494		
20.00	60.0	20	130	32496	56346	

DIXI 7232

FRAISES À DENTURE DROITE

Z = 2

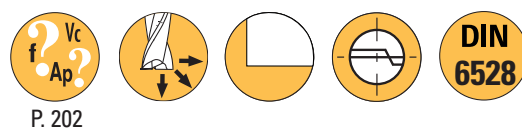

P. 202

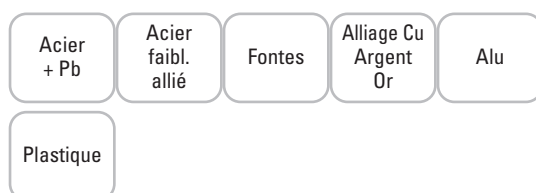
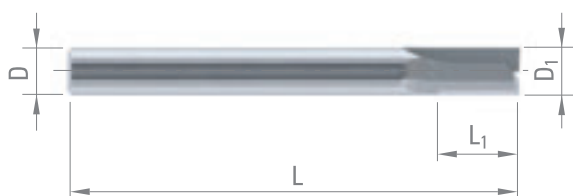

D_1 e8	L_1	D_{h5}	L	CARBURE
2.00	6.0	2	38	42540
3.00	7.0	3	38	42541
4.00	8.0	4	50	42542
6.00	10.0	6	57	42543
8.00	16.0	8	63	42544



DIXI 7243

FRAISES EN BOUT HÉLICOÏDALES CORPS RENFORCÉ

Z = 3



P. 184



D₁ > 6

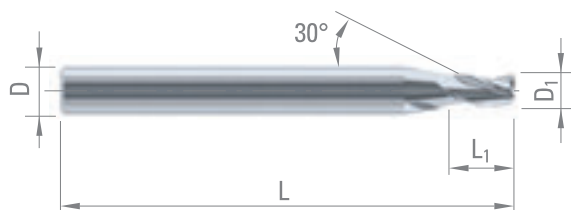

Acier + Pb	Acier faibl. allié	Acier fort. allié	Acier inox aust.	Fontes
Titane, alliage de titane	Alliage Cu Argent Or	Alliage Cu difficile	Alu	Plastique

D ₁	L ₁	D _{h5}	L	CARBURE	TiAIN
Ø < 2.00 - 0/-0.01					
Ø < 3.00 - 0/-0.02					
Ø ≥ 3.00 - e8					
0.35	1.0	3	38	956955	956956
0.40	1.2	3	38	956957	956958
0.50	1.5	3	38	48089	60914
0.60	1.8	3	38	61842	61841
0.70	2.1	3	38	61843	61844
0.75	2.4	3	38	48090	57205
0.80	2.4	3	38	66799	61845
0.90	2.7	3	38	60383	952308
1.00	3.0	3	38	48091	57206
1.10	3.3	3	38	59356	950790
1.20	3.6	3	38	39932	61352
1.25	3.9	3	38	48092	57207
1.30	3.9	3	38	49835	950044
1.40	4.2	3	38	60201	952191
1.50	4.5	3	38	48093	57208
1.60	4.8	3	38	64985	950045
1.70	5.1	3	38	57785	67283
1.75	5.4	3	38	48094	57209
1.80	5.4	3	38	50297	66988
1.90	5.7	3	38	66798	952309
2.00	6.0	3	38	42203	40868
2.10	7.0	3	38	45168	64847
2.20	7.0	3	38	57873	67276
2.30	7.0	3	38	40848	67277
2.40	7.0	3	38	42329	64809
2.50	7.0	3	38	41909	42105
3.00	7.0	6	57	41855	42106
3.50	7.0	6	57	41928	57210
4.00	8.0	6	57	41880	42341
4.50	8.0	6	57	41808	57211
5.00	10.0	6	57	41858	42107
5.50	10.0	6	57	41910	57690
6.00	10.0	6	57	41908	35589
6.00 >	12.0	8	63	43409	57214





P. 184



$D_1 > 6$



D_1 $\emptyset < 2.00 - 0/-0.01$ $\emptyset < 3.00 - 0/-0.02$ $\emptyset \geq 3.00 - e8$	L_1	D_{h5}	L	CARBURE	TIAIN
6.50	13.0	8	63	28948	57691
7.00	13.0	8	63	42562	57217
7.50	16.0	8	63	43920	57218
8.00	16.0	8	63	28951	57692
8.00 >	15.0	10	63	41809	36267
8.50	16.0	10	72	43215	57220
9.00	16.0	10	72	28953	57221
9.50	19.0	10	72	28954	57222
10.00	19.0	10	72	42357	57223
12.00	22.0	12	83	39945	57224
14.00	22.0	14	83	27781	57225
16.00	26.0	16	92	42358	57226
18.00	26.0	18	92	42359	57227
20.00	32.0	20	104	42360	57228

Acier + Pb	Acier faibl. allié	Acier fort. allié	Acier inox aust.	Fontes
Titane, alliage de titane	Alliage Cu Argent Or	Alliage Cu difficile	Alu	Plastique

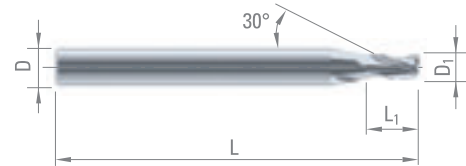



P. 184

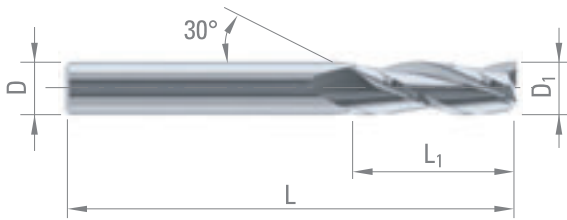

Acier + Pb	Acier faibl. allié	Acier fort. allié	Acier inox aust.	Fontes
Titane, alliage de titane	Alliage Cu Argent Or	Alliage Cu difficile	Alu	Plastique

D ₁ e8	L ₁	D _{h5}	L	CARBURE	TiAIN
2.00	8.0	2.0	32	701	57082
2.50	8.0	2.5	32	702	57089
3.00	10.0	3.0	38	703	57090
3.50	12.0	3.5	38	34761	57101
4.00	12.0	4.0	50	704	57102
5.00	15.0	5.0	50	34626	57103
6.00	18.0	6.0	50	34627	57104
7.00	20.0	7.0	60	27097	57105
8.00	25.0	8.0	63	707	57106
9.00	25.0	9.0	67	43184	57107
10.00	30.0	10.0	72	30853	57108
11.00	30.0	11.0	73	30938	57109
12.00	30.0	12.0	73	30854	57110
13.00	30.0	13.0	75	23885	57111
14.00	30.0	14.0	75	27071	57112
15.00	30.0	15.0	75	23886	57113
16.00	30.0	16.0	92	27072	57114
18.00	40.0	18.0	125	26086	57115
20.00	40.0	20.0	130	26087	57117



FRAISES EN BOUT HÉLICOÏDALES
LONGUES

Z = 3

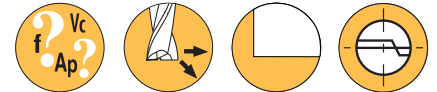

P. 196

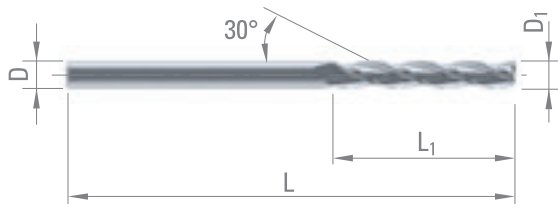

Acier + Pb	Acier faibl. allié	Acier fort. allié	Acier inox aust.	Fontes
Titane, alliage de titane	Alliage Cu Argent Or	Alliage Cu difficile	Alu	Graphite
Plastique				

D _{1 e8}	L ₁	D _{h5}	L	CARBURE	TiAIN	DIAMANT
3.00	30.0	3	60	44695	57141	60249
4.00	30.0	4	60	44696	57142	60250
5.00	35.0	5	75	44697	57143	60251
6.00	40.0	6	100	44698	57144	59009
8.00	40.0	8	100	44699	57145	60252
10.00	40.0	10	100	44700	57146	60253
12.00	45.0	12	100	44701	57147	60254
14.00	65.0	14	150	44702	57149	
16.00	65.0	16	150	44703	57150	
20.00	65.0	20	150	44705	57151	



DIXI 7333

FRAISES EN BOUT EXTRA COURTES

Z = 3



P. 198

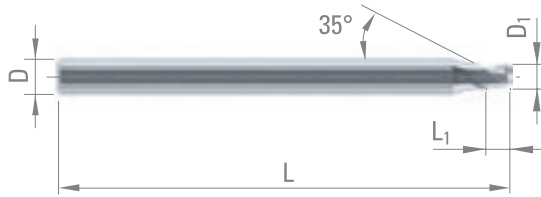

Acier + Pb	Acier faibl. allié	Acier fort. allié	Acier inox aust.	Fontes
Super alliages Ni / Co	Titane, alliage de titane	Alliage Cu Argent Or	Alliage Cu difficile	Alu
Plastique				

D_1	L_1	D_{h5}	L	CARBURE	CUTINOX
$\emptyset < 2.00 - 0/-0.01$					
$\emptyset < 3.00 - 0/-0.02$					
$\emptyset \geq 3.00 - e8$					
0.30	0.3	3	38	977779	977815
0.40	0.4	3	38	977780	977816
0.50	0.5	3	38	977781	977817
0.60	0.6	3	38	977782	977818
0.70	0.7	3	38	977783	977819
0.80	0.8	3	38	977784	977820
0.90	0.9	3	38	977785	977821
1.00	1.0	3	38	977786	977822
1.10	1.1	3	38	977787	977823
1.20	1.2	3	38	977788	977825
1.30	1.3	3	38	977789	977826
1.40	1.4	3	38	977790	977827
1.50	1.5	3	38	977791	977828
1.60	1.6	3	38	977792	977829
1.70	1.7	3	38	977793	977830
1.80	1.8	3	38	977794	977831
1.90	1.9	3	38	977795	977832
2.00	2.0	3	38	977796	977833
2.50	2.5	3	38	977797	977834
3.00	3.0	3	38	977798	977835
4.00	4.0	4	42	977799	977836
5.00	5.0	5	50	977800	977837
6.00	6.0	6	50	977801	977838
8.00	8.0	8	63	977802	977839
10.00	10.0	10	72	977803	977840



DIXI 7333-D

FRAISES EN BOUT EXTRA COURTES, DÉGAGÉES

Z = 3

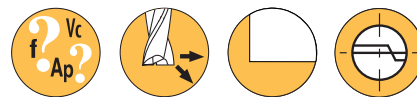

P. 198
P. 200

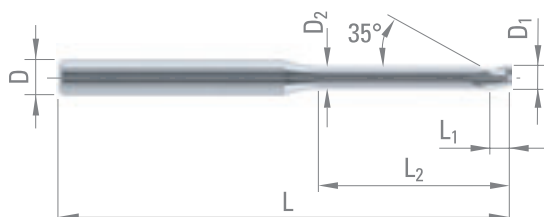

Acier + Pb	Acier faibl. allié	Acier fort. allié	Acier inox aust.	Fontes
Super alliages Ni / Co	Titane, alliage de titane	Alliage Cu Argent Or	Alliage Cu difficile	Alu
Plastique				

D₁ L₁ D₂ D_{h5} L L₂ DIXI CARBURE CUTINOX

∅ < 2.00 - 0/-0.01
∅ < 3.00 - 0/-0.02
∅ ≥ 3.00 - e8

D ₁	L ₁	D ₂	D _{h5}	L	L ₂	DIXI	CARBURE CUTINOX	
0.30	0.3	0.27	3	38	0.90	7333-3D	978791	978793
					1.50	7333-5D	978895	978896
					2.40	7333-8D	978591	978922
0.40	0.4	0.37	3	38	1.20	7333-3D	978794	978795
					2.00	7333-5D	978897	978898
					3.20	7333-8D	978928	979009
0.50	0.5	0.45	3	38	1.50	7333-3D	978796	978798
					2.50	7333-5D	978899	978900
					4.00	7333-8D	979010	979011
0.60	0.6	0.55	3	38	1.80	7333-3D	978799	978800
					3.00	7333-5D	978901	978902
					4.80	7333-8D	979012	979014
0.70	0.7	0.65	3	38	2.10	7333-3D	978801	978802
					3.50	7333-5D	978903	978904
					5.60	7333-8D	979016	979017
0.80	0.8	0.75	3	38	2.40	7333-3D	978803	978804
					4.00	7333-5D	978905	978906
					6.40	7333-8D	979018	979019
0.90	0.9	0.85	3	38	2.70	7333-3D	978805	978806
					4.50	7333-5D	978907	978908
					7.20	7333-8D	979020	979021
1.00	1.0	0.95	3	38	3.00	7333-3D	978807	978808
					5.00	7333-5D	978909	978910
					8.00	7333-8D	979022	979023
1.10	1.1	1.05	3	38	3.30	7333-3D	978809	978811
					5.50	7333-5D	978911	978912
					8.80	7333-8D	979024	979025
1.20	1.2	1.15	3	38	3.60	7333-3D	978812	978813
					6.00	7333-5D	978913	978914
					9.60	7333-8D	979026	979027
1.30	1.3	1.25	3	38	3.90	7333-3D	978814	978815
					6.50	7333-5D	978915	978916
					10.40	7333-8D	979028	979029
1.40	1.4	1.35	3	38	4.20	7333-3D	978816	978817
					7.00	7333-5D	978917	978918
					11.20	7333-8D	979030	979031
1.50	1.5	1.45	3	38	4.50	7333-3D	978818	978819
					7.50	7333-5D	978919	978920
					12.00	7333-8D	979032	979033
1.60	1.6	1.55	3	38	4.80	7333-3D	978820	978821
					8.00	7333-5D	978921	978923
					12.80	7333-8D	979034	979035
1.70	1.7	1.65	3	38	5.10	7333-3D	978823	978824
					8.50	7333-5D	978924	978925
					13.60	7333-8D	979036	979037
1.80	1.8	1.75	3	38	5.40	7333-3D	978826	978828
					9.00	7333-5D	978926	978927
					14.40	7333-8D	979038	979039
1.90	1.9	1.85	3	38	5.70	7333-3D	978829	978830
					9.50	7333-5D	978929	978930
					15.20	7333-8D	979041	979040

DIXI 7333-3D L₂ = 3 x D₁

DIXI 7333-5D L₂ = 5 x D₁

DIXI 7333-8D L₂ = 8 x D₁



DIXI 7333-D

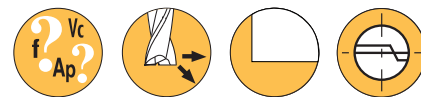

P. 198
P. 200

Acier + Pb	Acier faibl. allié	Acier fort. allié	Acier inox aust.	Fontes
Super alliages Ni / Co	Titane, alliage de titane	Alliage Cu Argent Or	Alliage Cu difficile	Alu
Plastique				

D₁ L₁ D₂ D_{h5} L L₂ DIXI CARBURE CUTINOX

Ø < 2.00 - 0/-0.01
Ø < 3.00 - 0/-0.02
Ø ≥ 3.00 - e8

D ₁	L ₁	D ₂	D _{h5}	L	L ₂	DIXI	CARBURE CUTINOX	
2.00	2.0	1.90	3	38	6.00	7333-3D	978848	978849
					10.00	7333-5D	978931	978932
					16.00	7333-8D	979042	979043
2.50	2.5	2.40	3	38	7.50	7333-3D	978850	978851
					12.50	7333-5D	978933	978934
					20.00	7333-8D	979044	979045
3.00	2.9	2.90	3	38	9.00	7333-3D	978852	978853
					15.00	7333-5D	978935	978936
					24.00	7333-8D	979046	979047
4.00	4.0	3.80	4	42	12.00	7333-3D	978854	978855

DIXI 7333-3D L₂ = 3 x D₁

DIXI 7333-5D L₂ = 5 x D₁

DIXI 7333-8D L₂ = 8 x D₁



DIXI 7543 XIDUR

FRAISES EN BOUT HÉLICOÏDALES
CORPS RENFORCÉ

Z = 3



P. 214

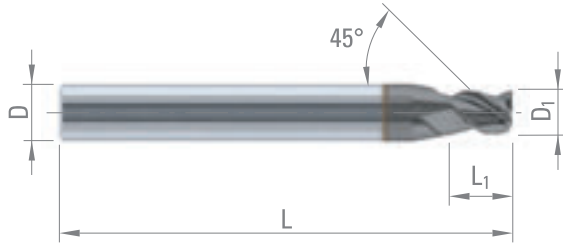

Acier
+ Pb

Acier
faibl.
allié

Acier
fort.
allié

Acier
inox
aust.

Fontes

Titane,
alliage de
titane

D₁ L₁ D_{h5} L XIDUR

Ø < 2.00 - 0/-0.01
Ø < 3.00 - 0/-0.02
Ø ≥ 3.00 - e8

1.00	2.0	4	50	51704
1.50	3.0	4	50	63945
2.00	3.0	4	50	51705
2.50	3.0	4	50	63946
3.00	4.5	6	57	51706
4.00	6.0	6	57	51707
5.00	7.0	6	57	51708
6.00	8.0	8	63	51709
8.00	10.0	10	72	51710
10.00	12.0	10	72	51711
12.00	15.0	12	83	51712



DIXI 7583

FRAISES EN BOUT HÉLICOÏDALES CORPS RENFORCÉ

Z = 3

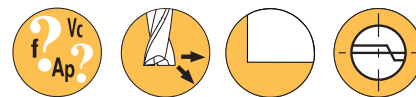

P. 184

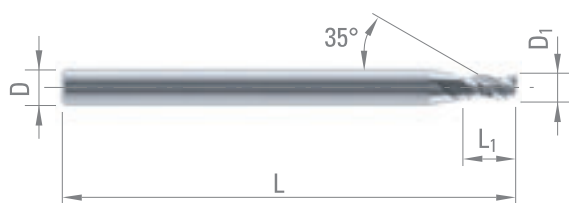

Acier + Pb	Acier faibl. allié	Acier fort. allié	Acier inox aust.	Fontes
Titane, alliage de titane	Alliage Cu Argent Or	Alliage Cu difficile	Alu	Plastique

D ₁	L ₁	D _{h5}	L	CARBURE	TiAIN	DLC
0.30	0.6	3	38	972403	972404	975572
0.40	0.8	3	38	972405	972406	982427
0.50	1.0	3	38	52565	963644	977361
0.60	1.2	3	38	963676	963678	982428
0.70	1.4	3	38	963677	963679	973037
0.80	1.6	3	38	954650	963680	982429
0.90	1.8	3	38	951666	963681	983104
1.00	2.0	3	38	31445	44659	960097
1.10	2.2	3	38	66496	66497	983105
1.20	2.4	3	38	66498	66499	973027
1.30	2.6	3	38	66500	66501	983106
1.40	2.8	3	38	66502	66503	983107
1.50	3.0	3	38	29407	40913	957103
1.60	3.2	3	38	41962	66510	983108
1.70	3.4	3	38	66504	66505	983109
1.80	3.6	3	38	66506	66507	983111
1.90	3.8	3	38	66508	66509	983112
2.00	4.0	3	38	39304	40081	61971
2.50	5.0	3	38	39213	40580	61973
3.00	6.0	6	50	40739	41954	61974
4.00	8.0	6	50	34377	53324	984169
5.00	10.0	6	50	48700	53325	984170
6.00	12.0	6	50	978074	978075	984171

Ø < 2.00 - 0/-0.01
Ø < 3.00 - 0/-0.02
Ø ≥ 3.00 - e8



DIXI 7253 CUTINOX

FRAISES À HÉLICES DIFFÉRENTES DÉGAGÉES

Z = 3



P. 186
P. 188

$D_1 \geq 10$

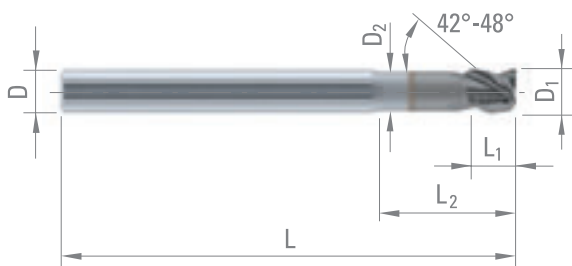

$D_{1\text{e8}}$	L_1	D_2	L_2	D_{h5}	L	CUTINOX
3.00	4.0	2.80	9	6	57	968764
4.00	5.0	3.70	12	6	57	968765
5.00	6.0	4.60	15	6	57	968766
6.00	7.0	5.50	18	8	63	968767
8.00	9.0	7.50	24	10	72	968768
10.00	11.0	9.30	30	10	72	968769
12.00	13.0	11.20	36	12	83	968770
16.00	17.0	15.20	48	16	92	968771
20.00	21.0	19.00	60	20	104	968772

Acier + Pb

Acier faibl. allié

Acier fort. allié

Acier inox aust.

Fontes

Super alliages Ni / Co

Titane, alliage de titane

DIXI 7273

FRAISES FINITION

Z = 3

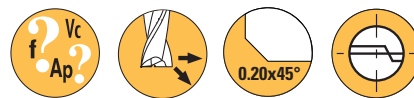

P. 184

$D_1 \geq 12$

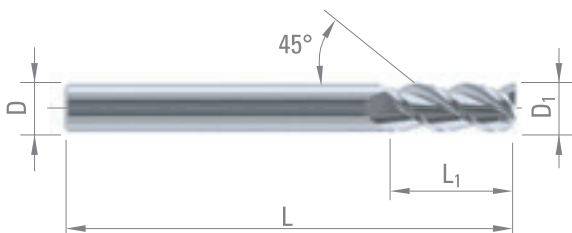

$D_{1\text{e8}}$	L_1	D_{h5}	L	CARBURE	TiAlN
3.00	10.0	3	38	35741	57254
4.00	12.0	4	50	35742	57255
5.00	14.0	5	50	34225	57256
6.00	16.0	6	57	35743	57258
8.00	20.0	8	63	34227	57259
10.00	22.0	10	72	34228	57260
12.00	22.0	12	73	34229	57261
16.00	27.0	16	82	35745	
20.00	35.0	20	104	35747	

Acier + Pb

Acier faibl. allié

Fontes

Titane, alliage de titane

Alliage Cu Argent Or

Alliage Cu difficile

Alu

Plastique



DIXI 7593

FRAISES EN BOUT HÉLICOÏDALES
DÉGAGÉES

Z = 3-4

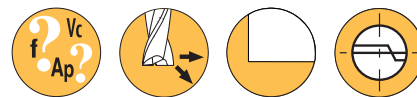

P. 214

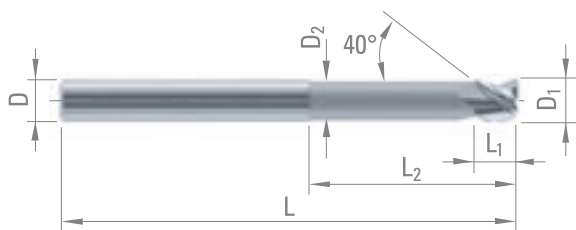

Alu

D _{1 h5}	L ₁	D ₂	L ₂	D _{h5}	L	Z	CARBURE
6.00	6.0	5.6	30	6	66	3	49281
8.00	8.0	7.6	45	8	81	3	49282
10.00	10.0	9.6	50	10	90	3	49283
12.00	12.0	11.6	55	12	100	3	49284
16.00	16.0	15.6	72	16	120	3	49285
20.00	20.0	19.6	80	20	130	4	49286

DIXI 7210

FRAISES ÉBAUCHE

Z = 3



P. 204

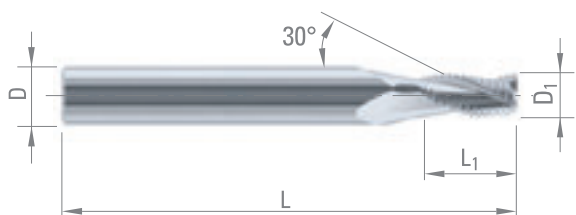

Acier
+ Pb

Acier
faibl.
allié

Acier
fort.
allié

Acier
inox
aust.

Fontes

Titane,
alliage de
titane

Alliage Cu
Argent
Or

Alliage
Cu
difficile

Alu

D _{1 d12}	L ₁	D _{h5}	L	CARBURE	CUTINOX
3.00	8.0	6	57	955178	955179
4.00	10.0	6	57	955092	955091
5.00	13.0	6	57	955089	955090
6.00	13.0	8	63	955088	955087
7.00	16.0	8	63	955086	955085
8.00	16.0	8	63	955082	955033
10.00	22.0	10	72	955093	955094
12.00	25.0	12	83	959048	956993



Sur demande

DIXI 7213

FRAISES ÉBAUCHE "PIRANHA"

Z = 3

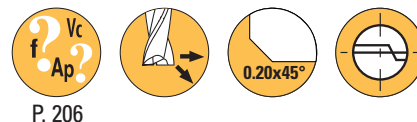

P. 206

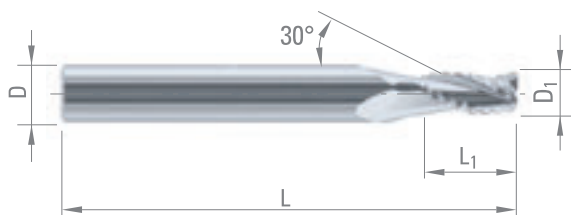

Acier + Pb	Acier faibl. allié	Acier fort. allié	Acier inox aust.	Fontes
Titane, alliage de titane	Alliage Cu Argent Or	Alliage Cu difficile	Alu	

D ₁ d12	L ₁	D _{h5}	L	CARBURE	TiAIN
4.00	10.0	6	57	31451	57018
5.00	13.0	6	57	37136	57019
6.00	13.0	8	63	37137	57020
7.00	16.0	8	63	37138	57021
8.00	16.0	10	72	43218	57022
10.00	22.0	10	72	43214	57024
11.00	22.0	12	83	37142	57025
12.00	25.0	12	83	37143	57026
14.00	27.0	14	83	37144	57027
16.00	36.0	16	100	37145	57028
20.00	40.0	20	104	37588	57029



Sur demande

DIXI 7215

FRAISES ÉBAUCHE ALU

Z = 3

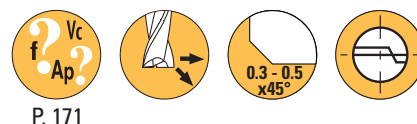

P. 171

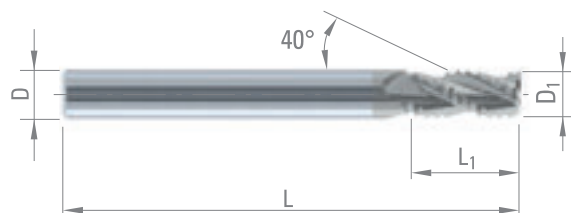

Alliage Cu Argent Or	Alliage Cu difficile	Alu
----------------------	----------------------	-----

D ₁ d12	L ₁	D _{h5}	L	DAC
6.00	13.0	6	57	993017
8.00	19.0	8	63	993018
10.00	22.0	10	72	993003
12.00	26.0	12	83	990143
16.00	32.0	16	92	993019



Sur demande

DIXI 7244

FRAISES EN BOUT HÉLICOÏDALES CORPS RENFORCÉ

Z = 4



P. 194

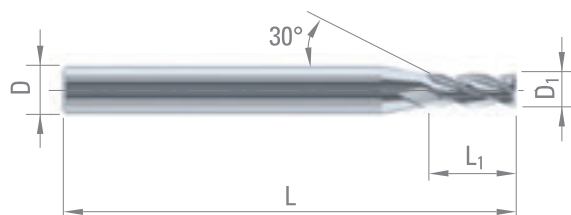

Acier + Pb	Acier faibl. allié	Acier fort. allié	Acier inox aust.	Fontes
Titane, alliage de titane	Alliage Cu Argent Or	Alliage Cu difficile	Alu	Graphite
Plastique				

D ₁	L ₁	D _{h5}	L	CARBURE	TiAlN	DIAMANT
0.40	1.2	3	38	45695	61846	
0.50	1.5	3	38	45696	61345	
1.00	3.0	3	38	55964	57230	63697
1.50	4.0	3	38	56731	57231	63698
2.00	7.0	3	38	52357	57232	63699
3.00	8.0	6	57	28959	57233	63700
4.00	11.0	6	57	42123	57239	63701
4.50	11.0	6	57	42124	57241	
5.00	13.0	6	57	41881	57242	63703
6.00	13.0	6	57	28965	57243	36278
7.00	16.0	8	63	28967	57244	
8.00	19.0	8	63	42906	57245	61617
9.00	19.0	10	72	28971	57246	
10.00	22.0	10	72	42361	57247	62563
12.00	26.0	12	83	39946	57248	
14.00	26.0	14	83	42362	57249	
16.00	32.0	16	92	42363	57251	
20.00	38.0	20	104	42227	57253	

Ø < 2.00 - 0/-0.01
Ø < 3.00 - 0/-0.02
Ø ≥ 3.00 - e8



DIXI 7204

FRAISES EN BOUT HÉLICOÏDALES

Z = 4

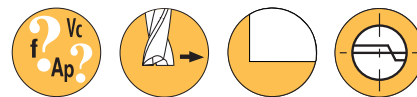

P. 194

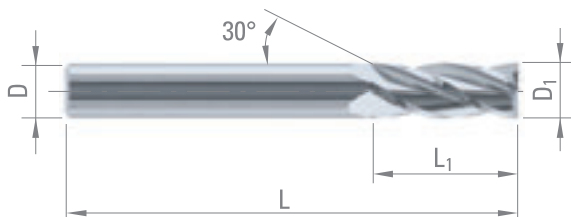

Acier + Pb	Acier faibl. allié	Acier fort. allié	Acier inox aust.	Fontes
Titane, alliage de titane	Alliage Cu Argent Or	Alliage Cu difficile	Alu	Plastique

D ₁ e8	L ₁	D _{h5}	L	CARBURE	TiAIN
2.00	8.0	2.0	32	32944	57118
2.50	8.0	2.5	32	32945	57119
3.00	10.0	3.0	38	710	57120
4.00	12.0	4.0	50	711	57121
5.00	14.0	5.0	50	34629	57122
6.00	16.0	6.0	50	34630	57123

DIXI 7224

FRAISES EN BOUT HÉLICOÏDALES LONGUES

Z = 4

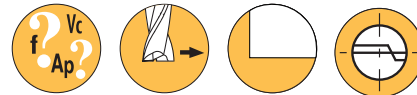

P. 196

D₁ ≥ 6

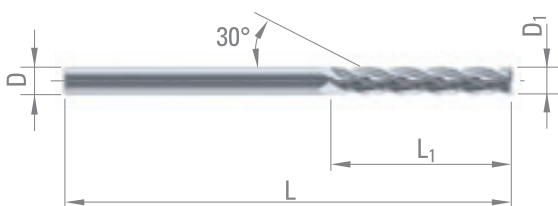

Acier + Pb	Acier faibl. allié	Fontes	Titane, alliage de titane	Alliage Cu Argent Or
Alliage Cu difficile	Alu	Graphite	Plastique	

D ₁ e8	L ₁	D _{h5}	L	CARBURE	TiAIN	DIAMANT
3.00	30.0	3	60	44769	57152	60255
4.00	30.0	4	60	44770	57154	60258
5.00	35.0	5	75	44771	57155	60259
6.00	40.0	6	100	44706	57156	60260
8.00	40.0	8	100	44772	57157	60003
10.00	40.0	10	100	44707	57158	60004
12.00	45.0	12	100	44773	57159	60261
14.00	65.0	14	150	44708	57160	
16.00	65.0	16	150	44709	55770	
20.00	65.0	20	150	44776	57161	



DIXI 7264 - 7264-3D CUTINOX

FRAISES À HÉLICES DIFFÉRENTES
ET PAS DÉCALÉ

Z = 4



P. 190
P. 192

$D_1 \geq 10$

7264

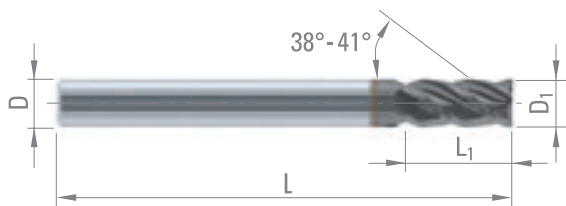

7264-3D

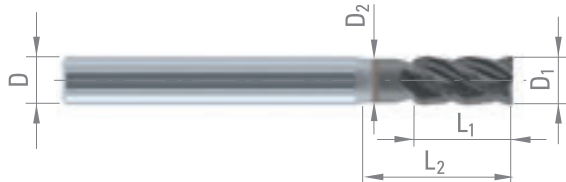

Acier
+ Pb

Acier
faibl.
allié

Acier
fort.
allié

Acier
inox
aust.

Fontes

Super
alliages
Ni / Co

Titane,
alliage de
titane

D_1
 $\emptyset < 3.00 - 0/-0.02$
 $\emptyset \geq 3.00 - e8$

D_1	L_1	D_{h5}	L	DIXI	D_2	L_2	CUTINOX
1.50	3.0	3	38	7264	-	-	974805
2.00	4.0	3	38	7264	-	-	974804
3.00	8.0	6	57	7264	-	-	968672
4.00	11.0	6	57	7264	-	-	968678
5.00	13.0	6	57	7264	-	-	968679
6.00	13.0	6	57	7264	-	-	968680
				7264-3D	5.5	18	997930
8.00	19.0	8	63	7264	-	-	968681
				7264-3D	7.5	24	997931
10.00	22.0	10	72	7264	-	-	968682
				7264-3D	9.25	30	997932
12.00	26.0	12	83	7264	-	-	968683
				7264-3D	11.0	36	997933
16.00	32.0	16	92	7264	-	-	968684
				7264-3D	15.0	48	997934
20.00	38.0	20	104	7264	-	-	968685
				7264-3D	19.0	60	997935



DIXI 7254 CUTINOX

FRAISES À HÉLICES DIFFÉRENTES
DÉGAGÉES

Z = 4

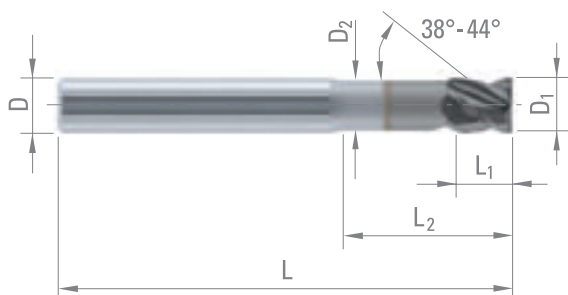

P. 186
P. 188



$D_1 \geq 10$



Acier
+ Pb

Acier
faibl.
allié

Acier
fort.
allié

Acier
inox
aust.

Fontes

Super
alliages
Ni / Co

Titane,
alliage de
titane

$D_{1\ e8}$	L_1	D_2	L_2	D_{h5}	L	CUTINOX
3.00	4.0	2.80	9	6	57	968686
4.00	5.0	3.70	12	6	57	968687
5.00	6.0	4.60	15	6	57	968688
6.00	7.0	5.50	18	8	63	968689
8.00	9.0	7.50	24	10	72	968690
10.00	11.0	9.30	30	10	72	968691
12.00	13.0	11.20	36	12	83	968692
16.00	17.0	15.20	48	16	92	968693
20.00	21.0	19.00	60	20	104	968694

DIXI 7214

FRAISES ÉBAUCHE "PIRANHA"

Z = 4

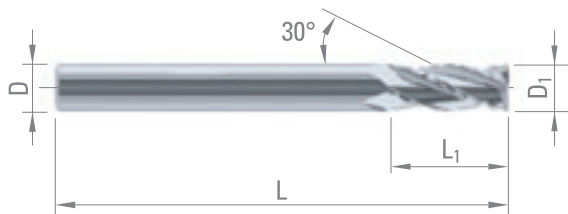

P. 206



Acier
+ Pb

Acier
faibl.
allié

Acier
fort.
allié

Acier
inox
aust.

Fontes

Titane,
alliage de
titane

Alliage Cu
Argent
Or

Alliage
Cu
difficile

Alu

Plastique

$D_{1\ d12}$	L_1	D_{h5}	L	CARBURE	TiAIN
6.00	15.0	6	57	45798	61412
8.00	16.0	10	72	39954	62426
10.00	22.0	10	72	37146	31133
12.00	25.0	12	83	37148	60949
14.00	30.0	14	83	37150	63332
16.00	36.0	16	100	37151	63333
20.00	40.0	20	104	37152	63334



Sur demande

DIXI 7560

FRAISES MULTIDENTS HÉLICOÏDALES

Z = 3-8



P. 202



$D_1 > 6$



$D_1 \leq 1.90$

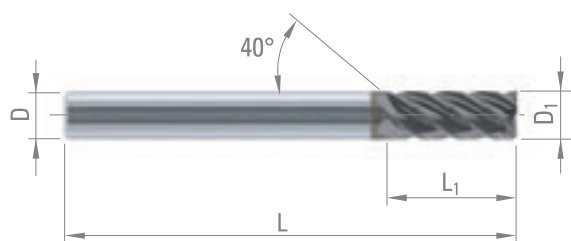

Acier + Pb	Acier faibl. allié	Acier fort. allié	Acier inox aust.	Fontes
Super alliages Ni / Co	Titane, alliage de titane	Alliage Cu Argent Or	Alliage Cu difficile	

D_1	L_1	D_{h5}	L	Z	CARBURE	TiAIN	DLC
$\emptyset < 2.00 - 0 / -0.01$							
$\emptyset \geq 2.00 - e8$							
0.35	0.90	3.0	38	3	964114	966117	966057
0.40	1.00	3.0	38	3	964115	966118	966058
0.45	1.10	3.0	38	3	964116	966119	966059
0.50	1.25	3.0	38	3	964117	966120	966060
0.55	1.40	3.0	38	3	964118	966121	966061
0.60	1.50	3.0	38	3	964119	966122	966062
0.65	1.70	3.0	38	3	964120	966123	966063
0.70	1.75	3.0	38	3	964121	966124	966064
0.75	1.90	3.0	38	3	964122	966125	966065
0.80	2.00	3.0	38	3	964123	966126	966066
0.85	2.15	3.0	38	3	964124	966127	966067
0.90	2.25	3.0	38	3	964125	966128	966068
0.95	2.40	3.0	38	3	964126	966129	966069
1.00	2.50	3.0	38	3	964127	966130	966070
1.10	2.75	3.0	38	3	964128	966131	966071
1.20	3.00	3.0	38	3	964129	966132	966072
1.30	3.25	3.0	38	3	964130	966133	966073
1.40	3.50	3.0	38	3	964131	966134	966074
1.50	3.75	3.0	38	3	964132	966136	966075
1.60	4.00	3.0	38	3	964133	966138	966076
1.70	4.25	3.0	38	3	964134	966139	966094
1.80	4.50	3.0	38	3	964135	966140	966095
1.90	4.75	3.0	38	3	964136	966142	966096
2.00	8.00	3.0	38	5	964108	964112	964113
2.10	5.25	3.0	38	5	964137	966145	966097
2.20	5.50	3.0	38	5	964140	966146	966098
2.30	5.75	3.0	38	5	964141	966147	966099
2.40	6.00	3.0	38	5	964142	966148	966101
2.50	8.00	3.0	38	5	964109	964110	964111
2.60	6.50	3.0	38	5	964143	966149	966102
2.70	6.75	3.0	38	5	964144	966150	966104
2.80	7.00	3.0	38	5	964145	966151	966105
2.90	7.00	3.0	38	5	964146	966152	966106
3.00	10.00	3.0	38	5	45657	49683	966107
4.00	12.00	4.0	50	5	45658	49684	964325
5.00	14.00	5.0	50	5	45659	49685	966115
6.00	16.00	6.0	57	5	45546	49686	966116
8.00	19.00	8.0	63	5	45547	49688	
9.00	22.00	9.0	67	5	45661	49689	
10.00	22.00	10.0	72	6	45548	49690	
12.00	26.00	12.0	83	6	45662	49691	
16.00	32.00	16.0	92	6	45549	49693	
20.00	38.00	20.0	104	8	45550	49694	



DIXI 7520 XIDUR

FRAISES MULTIDENTS HÉLICOÏDALES

Z = 3-10



P. 218



$D_1 \geq 6$



$D_1 \leq 1.50$

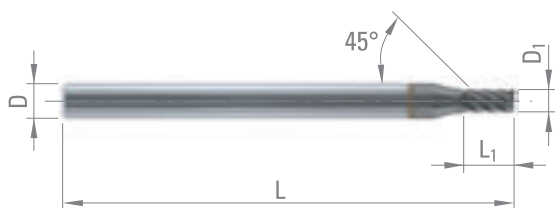

Acier
fort.
allié

Aciers
Fontes
45-65 HRC

Super
alliages
Ni / Co

D_1	L_1	D_{h5}	L	Z	XIDUR
$\varnothing < 2.00 - 0/-0.01$					
$\varnothing < 3.00 - 0/-0.02$					
$\varnothing \geq 3.00 - e8$					

0.40	0.8	3	38	3	956595
0.50	1.0	3	38	3	956596
0.60	1.2	3	38	3	956597
0.70	1.4	3	38	3	956598
0.80	1.6	3	38	3	956599
0.90	1.8	3	38	3	956600
1.00	2.0	3	38	4	956601
1.50	3.0	3	38	4	956602
2.00	4.0	3	38	5	956603
2.50	5.0	3	38	5	957465
3.00	6.0	3	38	5	49107
4.00	8.0	4	50	5	49108
6.00	12.0	6	57	6	49109
8.00	16.0	8	63	6	49110
10.00	20.0	10	72	6	49111
12.00	24.0	12	83	8	49112
16.00	32.0	16	92	10	49113



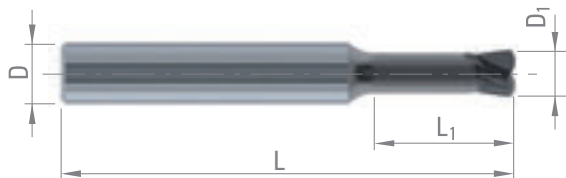

Acier + Pb	Acier faibl. allié	Acier fort. allié	Acier inox aust.	Aciers Fontes 45-65 HRC
Fontes	Super alliages Ni / Co	Titane, alliage de titane	Alliage Cu Argent Or	Alliage Cu difficile
Alu	Graphite			

D ₁	L ₁	D _{h6}	L	XIDUR
0.50	1.50	6	40	305279
0.80	2.40	6	40	305280
1.00	3.00	6	40	997920
1.50	4.50	6	40	997921
2.00	6.00	6	40	997922
3.00	9.00	6	40	997923
4.00	12.00	6	60	997924
5.00	15.00	6	60	997925
6.00	18.00	8	63	997926
8.00	24.00	10	80	997927
10.00	30.00	10	80	997928
12.00	36.00	12	80	997929

Téléchargez les conditions de coupe (pdf + xls) et les profils dxf sur www.dixipolytool.com



DIXI 7237-10

FRAISES TORIQUES EXTRA COURTES, DÉGAGÉES, $L_2 = 3 \times D_1$

Z = 2



P. 180

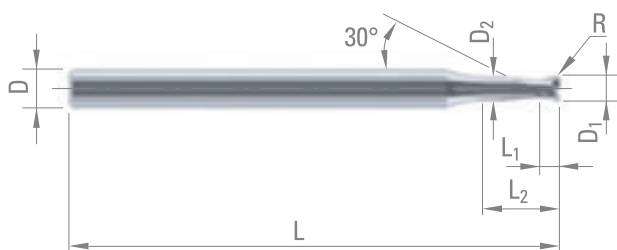

Acier + Pb	Acier faibl. allié	Acier fort. allié	Acier inox aust.	Fontes
Super alliages Ni / Co	Titane, alliage de titane	Alliage Cu Argent Or	Alliage Cu difficile	Alu
Plastique				

D_1	L_1	D_2	L_2	D_{h5}	L	R	CARBURE	TiAIN
$\emptyset < 2.00 - 0/-0.01$								
$\emptyset < 3.00 - 0/-0.02$								
$\emptyset \geq 3.00 - e8$								
0.40	0.40	0.37	1.20	3	38	0.05	958447	958452
0.45	0.45	0.42	1.35	3	38	0.05	958453	958454
0.50	0.50	0.45	1.50	3	38	0.05	958455	958456
0.55	0.55	0.50	1.65	3	38	0.05	958457	958458
0.60	0.60	0.55	1.80	3	38	0.05	958465	958466
0.65	0.65	0.60	1.95	3	38	0.05	958467	958468
0.70	0.70	0.65	2.10	3	38	0.05	958469	958470
0.75	0.75	0.70	2.25	3	38	0.05	958472	958473
0.80	0.80	0.75	2.40	3	38	0.05	958474	958475
0.85	0.85	0.80	2.55	3	38	0.05	958476	958477
0.90	0.90	0.85	2.70	3	38	0.10	958478	958479
0.95	0.95	0.90	2.85	3	38	0.10	958481	958482
1.00	1.00	0.95	3.00	3	38	0.10	958483	958484
1.05	1.05	1.00	3.15	3	38	0.10	958486	958487
1.10	1.10	1.05	3.30	3	38	0.10	958488	958489
1.15	1.15	1.10	3.45	3	38	0.10	958490	958491
1.20	1.20	1.15	3.60	3	38	0.10	958492	958493
1.25	1.25	1.20	3.75	3	38	0.10	958494	958495
1.30	1.30	1.25	3.90	3	38	0.10	958496	958497
1.35	1.35	1.30	4.05	3	38	0.10	958499	958501
1.40	1.40	1.35	4.20	3	38	0.10	958502	958503
1.45	1.45	1.40	4.35	3	38	0.10	958504	958505
1.50	1.50	1.45	4.50	3	38	0.20	958506	958507
1.55	1.55	1.50	4.65	3	38	0.20	958508	958509
1.60	1.60	1.55	4.80	3	38	0.20	958510	958511
1.65	1.65	1.60	4.95	3	38	0.20	958512	958513
1.70	1.70	1.65	5.10	3	38	0.20	958514	958515
1.75	1.75	1.70	5.25	3	38	0.20	958516	958517
1.80	1.80	1.75	5.40	3	38	0.20	958518	958519
1.85	1.85	1.80	5.55	3	38	0.20	958520	958521
1.90	1.90	1.85	5.70	3	38	0.20	958522	958523
1.95	1.95	1.90	5.85	3	38	0.20	958524	958525
2.00	2.00	1.90	6.00	6	50	0.20	958527	958531
2.10	2.10	2.00	6.30	6	50	0.20	958532	958533
2.20	2.20	2.10	6.60	6	50	0.20	958534	958535
2.30	2.30	2.20	6.90	6	50	0.20	958886	958887
2.40	2.40	2.30	7.20	6	50	0.20	958888	958889
2.50	2.50	2.40	7.50	6	50	0.20	958890	958891
3.00	3.00	2.90	9.00	6	50	0.20	958892	958893



DIXI 7070 XIDUR

FRAISES TORIQUES MULTIDENTS
DÉGAGÉES

Z = 4-6



P. 219

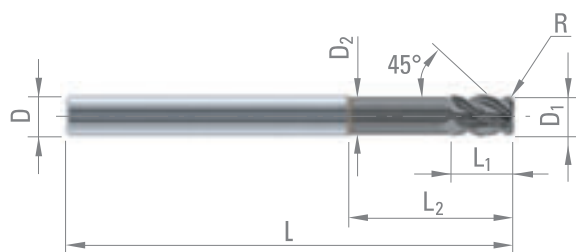

Acier
fort.
allié

Aciers
Fontes
45-65 HRC

Super
alliages
Ni / Co

D _{1 e8}	L ₁	D ₂	L ₂	D _{h5}	L	Z	R	XIDUR
3.00	4.5	2.75	12.0	6	57	4	0.5	56643
4.00	6.0	3.70	13.5	6	57	4	0.5	56644
5.00	7.5	4.60	17.5	6	57	4	0.5	56645
							0.5	56627
6.00	9.0	5.50	24.0	6	66	4	0.8	56646
							1.0	56628
							1.5	56647
							0.5	56634
8.00	10.0	7.50	28.0	8	75	4	1.0	56635
							1.5	56648
							2.0	56649
							0.5	56636
							1.0	56637
10.00	12.0	9.25	30.0	10	75	6	1.5	56650
							2.0	56651
							2.5	56652
							1.0	56653
12.00	12.0	11.00	32.0	12	83	6	1.5	56654
							2.0	56655
							3.0	56656



DIXI 7265

FRAISES À HÉLICES DIFFÉRENTES ET RAYON PARTIEL

Z = 4



P. 190
P. 192

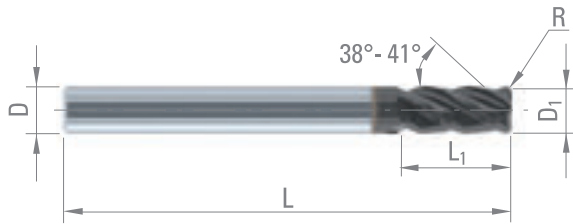

Acier + Pb

Acier faibl. allié

Acier fort. allié

Acier inox aust.

Fontes

Super alliages Ni / Co

Titane, alliage de titane

D ₁ Ø < 3.00 - 0/-0.02 Ø ≥ 3.00 - e8	L ₁	D _{h5}	L	R	CUTINOX
2.00	4.0	3	38	0.5	997936
3.00	8.0	6	57	0.5	997937
4.00	11.0	6	57	0.5	997938
5.00	13.0	6	57	0.5	997939
6.00	13.0	6	57	0.5	997940
				1.0	997941
8.00	19.0	8	63	0.5	997942
				1.0	997943
10.00	22.0	10	72	0.5	997944
				1.0	997945
12.00	26.0	12	83	0.5	997946
				1.0	997947



DIXI 7554

FRAISES TORIQUES HÉLICOÏDALES DÉGAGÉES

Z = 4



P. 194



D₁ ≥ 6

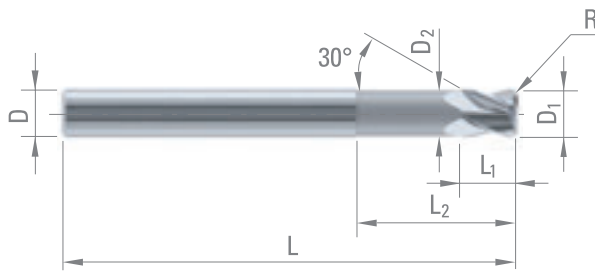

Acier + Pb	Acier faibl. allié	Acier fort. allié	Acier inox aust.	Fontes
Titane, alliage de titane	Alliage Cu Argent Or	Alliage Cu difficile	Alu	Plastique

D ₁	L ₁	D ₂	L ₂	D _{h5}	L	R	CARBURE	TiAIN
∅ < 3.00 - 0/-0.02								
∅ ≥ 3.00 - e8								
2.00	3.0	1.90	10	4	42	0.2	64465	64466
3.00	4.0	2.80	15	6	57	0.2	64467	64468
4.00	5.0	3.80	18	6	57	0.3	64469	64470
6.00	7.0	5.70	20	6	57	0.5	64471	64472
						1.0	64473	64474
8.00	10.0	7.70	30	8	63	0.5	64475	64476
						1.0	64477	64478
10.00	12.0	9.60	35	10	72	0.5	64479	64480
						1.0	64481	64482
12.00	14.0	11.50	40	12	83	0.5	64485	64486
						1.0	64487	64488



DIXI 7552

FRAISES TORIQUES HÉLICOÏDALES DÉGAGÉES

Z = 2



P. 212

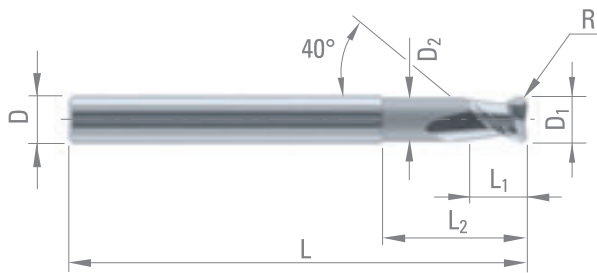

Acier + Pb	Acier faibl. allié	Fontes	Titane, alliage de titane	Alliage Cu Argent Or
Alliage Cu difficile	Alu	Plastique		

D ₁ e8	L ₁	D ₂	L ₂	D _{h5}	L	R	CARBURE	DICUT
3.00	4.0	2.75	10	6	57	0.5	60765	63493
4.00	5.0	3.70	12	6	57	0.5	60766	63494
5.00	6.0	4.60	15	6	57	0.5	60767	63495
6.00	7.0	5.50	18	6	57	1.0	60768	63496
8.00	9.0	7.50	23	8	63	1.0	60769	63497
10.00	11.0	9.25	30	10	75	1.5	60770	63498
12.00	13.0	11.00	35	12	83	1.5	60771	63499
16.00	17.0	15.00	44	16	92	2.0	60772	952918



FRAISES HÉMISPHERIQUES

Z = 2

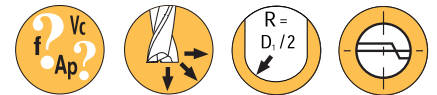

P. 172

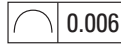
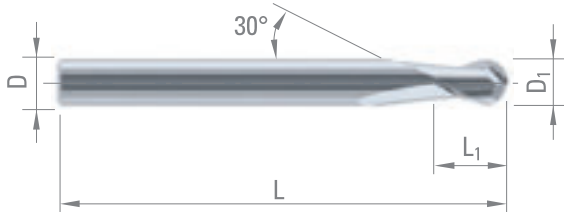

Acier + Pb	Acier faibl. allié	Acier fort. allié	Acier inox aust.	Fontes
Super alliages Ni / Co	Titane, alliage de titane	Alliage Cu Argent Or	Alliage Cu difficile	Alu
Graphite	Plastique			

D₁ L₁ D_{h5} L CARBURE TiAIN DICUT DIAMANT
 Ø < 0.30 - 0/-0.01
 Ø < 3.00 - 0/-0.02
 Ø ≥ 3.00 - e8

D ₁	L ₁	D _{h5}	L	CARBURE TiAIN	DICUT	DIAMANT	
0.06	0.12	3	38	959060			
0.08	0.16	3	38	959059			
0.10	0.20	3	38	959058			
0.15	0.30	3	38	954665			
0.20	0.30	3	38	952795	952796	952797	952799
0.25	0.40	3	38	952800	952801	952802	952803
0.30	0.50	3	38	952804	952805	952806	58852
0.40	0.60	3	38	952807	952808	952809	952810
0.50	0.80	3	38	952811	952812	952813	952814
0.60	0.90	3	38	952815	952816	952817	952818
0.70	1.10	3	38	952819	952820	952821	950363
0.80	1.20	3	38	952822	952823	950703	950364
0.90	1.40	3	38	952825	952826	952824	950365
1.00	1.50	3	38	952827	952828	952829	952830
1.10	1.70	3	38	952832	952833	952831	950366
1.20	1.80	3	38	952835	952836	952834	950367
1.30	1.90	3	38	952838	952839	952837	950368
1.40	2.10	3	38	952841	952842	952840	950369
1.50	2.30	3	38	952843	952846	952845	952844
1.60	2.50	3	38	55539	955784	956236	956237
1.70	2.50	3	38	60112	956238	956239	956240
1.80	2.75	3	38	48747	956241	956242	956243
1.90	2.75	3	38	57714	956244	956245	956246
2.00	3.00	3	38	44604	56136	64280	59783
2.10	3.00	3	38	55540	956247	956248	956249
2.20	3.50	3	38	48457	956250	956251	956253
2.30	3.50	3	38	66547	62925	956254	956255
2.40	3.50	3	38	60788	62926	956256	956257
2.50	4.00	3	38	44605	56137	64288	60221
3.00	5.00	3	38	43115	56138	63876	59988
3.50	6.00	4	50	44607	56139	64289	950370
4.00	6.00	4	50	34120	56140	64290	59784
4.50	7.00	5	50	44609	56141	64291	950371
5.00	8.00	5	50	34748	36172	64292	60222
5.50	9.00	6	57	44611	56172	64293	950372
6.00	9.00	6	57	34749	56179	63923	46800
7.00	11.00	7	60	34740	56176	64294	66878
8.00	12.00	8	63	43389	36174	64295	58860
10.00	15.00	10	72	42940	56177	63924	36175
12.00	18.00	12	73	32387	56173	64296	60223
14.00	21.00	14	75	32388	56174		
16.00	24.00	16	82	32136	56175		
20.00	30.00	20	104	35736	56183		

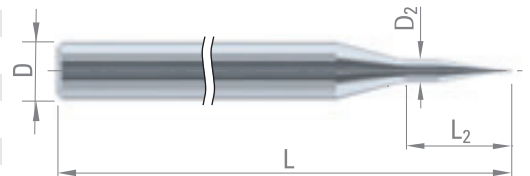

Pour D₁ ≤ 0.15:
 D₂ = 1.20
 L₂ = 5.30

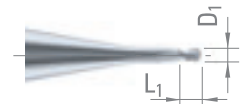

FRAISES HÉMISPHERIQUES

Z = 2

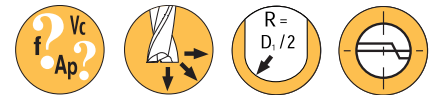

P. 178

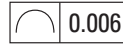
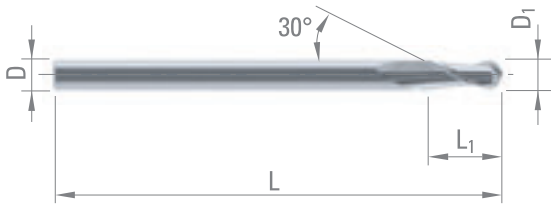

Acier + Pb	Acier faibl. allié	Acier fort. allié	Acier inox aust.	Fontes
Super alliages Ni / Co	Titane, alliage de titane	Alliage Cu Argent Or	Alliage Cu difficile	Alu
Graphite	Plastique			

D _{1 e8}	L ₁	D _{h5}	L	CARBURE	TiAIN	DIAMANT
2.00	10	2	61	41974	56238	60224
3.00	10	3	61	39512	56239	60225
4.00	12	4	75	38639	56240	60226
5.00	14	5	86	38942	56241	60227
6.00	16	6	93	38623	56242	60228
8.00	20	8	100	38640	56243	60229
10.00	24	10	100	38641	56244	58790
12.00	28	12	110	40728	56245	60230
16.00	36	16	120	40730	56247	
20.00	45	20	150	40732	56248	



FRAISES HÉMISPHERIQUES
DÉGAGÉES

Z = 2



P. 176

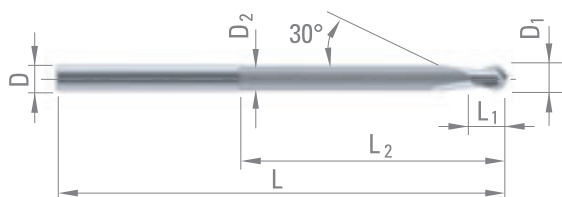

0.006

Acier + Pb	Acier faibl. allié	Acier fort. allié	Acier inox aust.	Fontes
Super alliages Ni / Co	Titane, alliage de titane	Alliage Cu Argent Or	Alliage Cu difficile	Alu
Graphite	Plastique			

D ₁	L ₁	D ₂	L ₂	D _{h5}	L	CARBURE	TAIN	DICUT	DIAMANT
0.20	0.5	0.18	1.0	4	55	64714	64719	64724	64729
0.30	0.6	0.27	1.5	4	55	64715	64720	64725	64730
0.40	0.8	0.37	2.0	4	55	64716	64721	64726	64731
0.50	1.0	0.45	3.0	4	55	64542	64556	64572	64584
0.60	1.6	0.55	4.0	4	55	64717	64722	64727	64732
0.80	1.8	0.75	5.0	4	55	64718	64723	64728	64733
1.00	2.0	0.95	6.0	4	55	64544	64557	64573	64585
1.50	2.5	1.45	9.0	4	55	64546	64558	64574	64586
2.00	3.0	1.90	12.0	4	55	64547	64559	64575	64587
2.50	4.0	2.40	12.0	4	55	64548	64560	64576	64588
3.00	5.0	2.80	12.0	6	57	64549	64561	64577	64589
4.00	6.0	3.80	15.0	6	57	64550	64562	64578	64590
5.00	7.0	4.80	15.0	6	57	64551	64567	64579	64591
6.00	8.0	5.70	15.0	6	57	64552	64568	64580	64592
8.00	10.0	7.70	25.0	8	63	64553	64569	64581	64593
10.00	12.0	9.60	30.0	10	72	64554	64570	64582	64594
12.00	14.0	11.60	40.0	12	83	64555	64571	64583	64595

Ø < 3.00 - 0/-0.02
Ø ≥ 3.00 - e8



DIXI 7045 - 7047-D

FRAISES HÉMISPHERIQUES DÉGAGÉES

Z = 2



P. 176

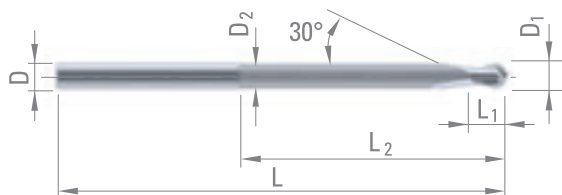

0.006

Acier + Pb	Acier faibl. allié	Acier fort. allié	Acier inox aust.	Fontes
Super alliages Ni / Co	Titane, alliage de titane	Alliage Cu Argent Or	Alliage Cu difficile	Alu
Graphite	Plastique			

D ₁	L ₁	D ₂	D _{h5}	L	L ₂	DIXI	CARBURE	TiAIN	DICUT	DIAMANT	
Ø < 3.00 - 0/-0.02 Ø ≥ 3.00 - e8	0.20	0.5	0.18	4	62	1.0	7045	64694	64699	64704	64709
						1.6	7047-8D	979531	979555	979576	979595
2.0						7047-10D	64735	64742	64750	64755	
2.4						7047-12D	979613	979626	979639	979664	
3.0						7047-15D	979711	979722	979732	979744	
3.6						7047-18D	979756	979768	979779	979790	
1.5						7045	64695	64700	64705	64710	
2.4						7047-8D	979534	979558	979578	979596	
3.0						7047-10D	64738	64743	64751	64756	
3.6						7047-12D	979614	979627	979640	979652	
4.5						7047-15D	979712	979724	979733	979745	
5.4						7047-18D	979757	979769	979780	979791	
2.0						7045	64696	64701	64706	64711	
3.2						7047-8D	979535	979559	979579	979597	
4.0						7047-10D	64739	64744	64752	64757	
4.8						7047-12D	979615	979628	979641	979653	
6.0						7047-15D	979713	979723	979734	979746	
7.2						7047-18D	979758	979770	979781	979792	
3.0						7045	64491	64503	64515	64527	
4.0						7047-8D	979536	979560	979580	979598	
5.0	7047-10D	64596	64608	64623	64635						
6.0	7047-12D	979616	979629	979642	979654						
7.5	7047-15D	979714	979725	979735	979747						
9.0	7047-18D	979759	979771	979782	979793						
4.0	7045	64697	64702	64707	64712						
4.8	7047-8D	979537	979561	979581	979599						
6.0	7047-10D	64740	64745	64753	64758						
7.2	7047-12D	979617	979630	979643	979655						
9.0	7047-15D	979715	979726	979736	979748						
10.8	7047-18D	979760	979772	979783	979794						
5.0	7045	64698	64703	64708	64713						
6.4	7047-8D	979538	979562	979582	979600						
8.0	7047-10D	64741	64746	64754	64759						
9.6	7047-12D	979618	979631	979644	979656						
12.0	7047-15D	979716	979727	979737	979749						
14.4	7047-18D	979761	979773	979784	979795						
6.0	7045	64492	64504	64516	64528						
8.0	7047-8D	979540	979563	979583	979601						
10.0	7047-10D	64597	64609	64624	64636						
12.0	7047-12D	979619	954101	979314	979657						
15.0	7047-15D	975225	979728	979738	979750						
18.0	7047-18D	979522	979774	979785	979523						
9.0	7045	64493	64505	64517	64529						
12.0	7047-8D	979541	979565	979585	979602						
15.0	7047-10D	64598	64610	64625	64637						
18.0	7047-12D	979620	979632	979645	979658						
22.5	7047-15D	979717	979729	979739	979751						
27.0	7047-18D	979763	979775	979786	979799						



DIXI 7045 - 7047-D



P. 176

Acier + Pb	Acier faibl. allié	Acier fort. allié	Acier inox aust.	Fontes
Super alliages Ni / Co	Titane, alliage de titane	Alliage Cu Argent Or	Alliage Cu difficile	Alu
Graphite	Plastique			

D ₁	L ₁	D ₂	D _{h5}	L	L ₂	DIXI	CARBURE	TAIN	DICUT	DIAMANT	
Ø < 3.00 - 0/-0.02 Ø ≥ 3.00 - e8	2.00	3.0	1.90	4	75	12.0	7045	64494	64506	64518	64530
						16.0	7047-8D	979542	979566	979588	979603
2.00	3.0	1.90	4	75	75	20.0	7047-10D	64599	64611	64626	64638
						24.0	7047-12D	979621	979633	979646	979659
						30.0	7047-15D	972993	954105	979740	979752
						36.0	7047-18D	979765	979776	979787	979796
						12.0	7045	64495	64507	64519	64531
						20.0	7047-8D	979544	979567	979589	979604
2.50	4.0	2.40	4	75	75	25.0	7047-10D	64600	64612	64627	64639
						30.0	7047-12D	979622	979635	979648	979660
						37.5	7047-15D	979719	979718	979741	979753
						45.0	7047-18D	979766	979777	979788	979797
						12.0	7045	64496	64508	64520	64532
3.00	5.0	2.80	6	102	102	24.0	7047-8D	979545	979568	979590	979605
						30.0	7047-10D	64601	64613	64628	64640
						36.0	7047-12D	979623	979636	979649	979661
						45.0	7047-15D	979720	979730	979742	979754
						54.0	7047-18D	979767	979778	979789	979798
4.00	6.0	3.80	6	102	102	15.0	7045	64497	64509	64521	64533
						32.0	7047-8D	979547	979569	979591	979607
						40.0	7047-10D	64602	64614	64629	64641
						48.0	7047-12D	979624	979637	979650	979662
						60.0	7047-15D	979721	979731	979743	979755
5.00	7.0	4.80	6	102	102	15.0	7045	64498	64510	64522	64534
						40.0	7047-8D	979549	979570	979592	979608
						50.0	7047-10D	64603	64615	64630	64642
						60.0	7047-12D	979625	979638	979651	979663
6.00	8.0	5.70	6	102	102	15.0	7045	64499	64511	64523	64536
						48.0	7047-8D	979550	979571	979593	979609
						60.0	7047-10D	64604	64616	64631	64643
8.00	10.0	7.70	8	117	117	25.0	7045	64500	64512	64524	64537
						64.0	7047-8D	979551	979572	979594	979610
						80.0	7047-10D	64605	64617	64632	64644
10.00	12.0	9.60	10	133	133	30.0	7045	64501	64513	64525	64538
						80.0	7047-8D	979552	979573	979586	979611
						90.0	7047-10D	64606	64618	64633	64645
12.00	14.0	11.60	12	151	151	40.0	7045	64502	64514	64526	64539
						96.0	7047-8D	979553	979574	979587	979612
						110.0	7047-10D	64607	64619	64634	64646

DIXI 7045 $L_2 = 2.5-6 \times D_1$

DIXI 7047-8D $L_2 = 8 \times D_1$

DIXI 7047-10D $L_2 = 10 \times D_1$

DIXI 7047-12D $L_2 = 12 \times D_1$

DIXI 7047-15D $L_2 = 15 \times D_1$

DIXI 7047-18D $L_2 = 18 \times D_1$



DIXI 7532 XIDUR

FRAISES HÉMISPHÉRIQUES

Z = 2



P. 216

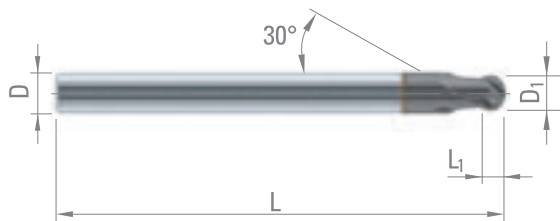

0.006

Acier fort. allié

Aciers Fontes 45-65 HRC

Super alliages Ni / Co

D ₁	L ₁	D _{h5}	L	XIDUR
0.20	0.2	4	50	973380
0.30	0.3	4	50	972176
0.40	0.4	4	50	973379
0.50	0.5	4	50	973378
0.60	0.6	4	50	973377
0.70	0.7	4	50	972177
0.80	0.8	4	50	973376
0.90	0.8	4	50	973375
1.00	0.8	4	50	67253
1.50	1.2	4	50	67254
2.00	1.6	4	50	67257
3.00	2.4	6	57	67258
4.00	3.2	6	66	67259
5.00	4.0	6	66	67260
6.00	4.8	6	66	67261
8.00	6.4	8	75	67262
10.00	8.0	10	90	67255



DIXI 7532-D XIDUR

FRAISES HÉMISPHERIQUES

Z = 2



P. 216

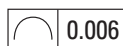
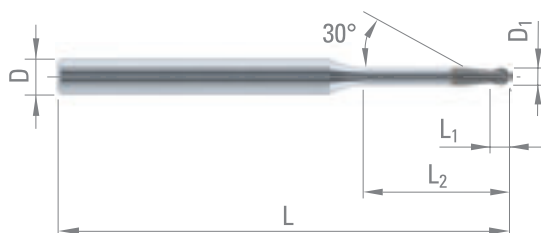

Acier fort. allié

Aciers Fontes 45-65 HRC

Super alliages Ni / Co

D ₁	L ₁	D _{h5}	L	L ₂	DIXI	XIDUR
0.20	0.2	4	50	0.6	7532-3D	978593
				1.0	7532-5D	979083
				1.6	7532-8D	979102
0.30	0.3	4	50	0.9	7532-3D	979058
				1.5	7532-5D	979084
				2.4	7532-8D	979103
0.40	0.4	4	50	1.2	7532-3D	979059
				2.0	7532-5D	979085
				3.2	7532-8D	979104
				4.0	7532-10D	979116
0.50	0.5	4	50	1.5	7532-3D	979060
				2.5	7532-5D	979086
				4.0	7532-8D	979105
				5.0	7532-10D	979117
				6.0	7532-12D	979136
0.60	0.6	4	50	1.8	7532-3D	979061
				3.0	7532-5D	979087
				4.8	7532-8D	979106
				6.0	7532-10D	979118
				7.2	7532-12D	979137
				9.0	7532-15D	979144
				2.1	7532-3D	979062
0.70	0.7	4	50	3.5	7532-5D	979088
				5.6	7532-8D	979107
				7.0	7532-10D	979119
				8.4	7532-12D	979138
				10.5	7532-15D	979145
				2.4	7532-3D	979063
0.80	0.8	4	50	4.0	7532-5D	979089
				6.4	7532-8D	979108
				8.0	7532-10D	979120
				9.6	7532-12D	979139
				12.0	7532-15D	979146
				2.7	7532-3D	979064
0.90	0.8	4	50	4.5	7532-5D	979091
				7.2	7532-8D	979109
				9.0	7532-10D	979121
				10.8	7532-12D	979140
				13.5	7532-15D	979147
				3.0	7532-3D	979065
1.00	0.8	4	50	5.0	7532-5D	979092
				8.0	7532-8D	979111
				10.0	7532-10D	979122
				12.0	7532-12D	979141
				15.0	7532-15D	979148
				4.5	7532-3D	979066
1.50	1.2	4	50	7.5	7532-5D	979093
				12.0	7532-8D	979112
				15.0	7532-10D	979123
				18.0	7532-12D	979142
				22.5	7532-15D	979149

DIXI 7532-3D

$$L_2 = 3 \times D_1$$

DIXI 7532-5D

$$L_2 = 5 \times D_1$$

DIXI 7532-8D

$$L_2 = 8 \times D_1$$

DIXI 7532-10D

$$L_2 = 10 \times D_1$$

DIXI 7532-12D

$$L_2 = 12 \times D_1$$

DIXI 7532-15D

$$L_2 = 15 \times D_1$$



DIXI 7532-D XIDUR

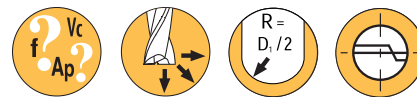

P. 216

D ₁	L ₁	D _{h5}	L	L ₂	X	XIDUR
Ø < 3.00 - 0/-0.02						
Ø ≥ 3.00 - e8						
2.00	1.6	4	50	6.0	7532-3D	979067
				10.0	7532-5D	979094
				16.0	7532-8D	979113
				20.0	7532-10D	979124
				24.0	7532-12D	979143
				30.0	7532-15D	979150
3.00	2.4	6	57	9.0	7532-3D	979068
				15.0	7532-5D	979095
				24.0	7532-8D	979114
				30.0	7532-10D	979125
4.00	3.2	6	66	12.0	7532-3D	979069
				20.0	7532-5D	979096
				32.0	7532-8D	979115
5.00	4.0	6	66	15.0	7532-3D	979070
				25.0	7532-5D	979097
6.00	4.8	6	66	18.0	7532-3D	979071
				30.0	7532-5D	979098
8.00	6.4	8	66	24.0	7532-3D	979072
				40.0	7532-5D	979099
10.00	8.0	10	66	30.0	7532-3D	979073
				50.0	7532-5D	979100

Acier fort. allié

Aciers Fontes 45-65 HRC

Super alliages Ni / Co

DIXI 7532-3D $L_2 = 3 \times D_1$

DIXI 7532-5D $L_2 = 5 \times D_1$

DIXI 7532-8D $L_2 = 8 \times D_1$

DIXI 7532-10D $L_2 = 10 \times D_1$

DIXI 7532-12D $L_2 = 12 \times D_1$

DIXI 7532-15D $L_2 = 15 \times D_1$

DIXI 7542 XIDUR

FRAISES HÉMISPHERIQUES DÉGAGÉES

Z = 2

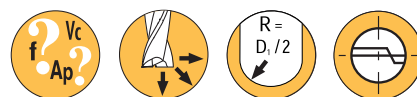

P. 217

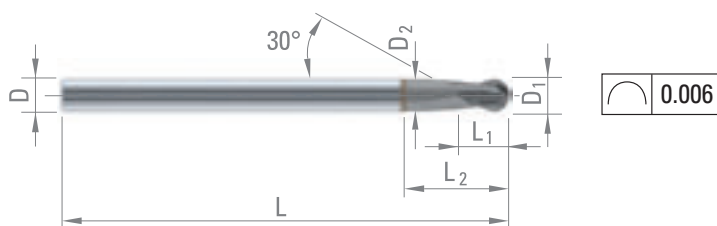

D ₁	L ₁	D ₂	L ₂	D _{h5}	L	XIDUR
Ø < 3.00 - 0/-0.02						
Ø ≥ 3.00 - e8						
1.00	2.0	0.90	3.2	6	66	61355
1.50	3.0	1.40	4.7	6	66	61356
2.00	3.0	1.85	6.2	6	66	61357
3.00	5.0	2.85	9.2	6	66	61358
4.00	6.0	3.80	12.5	6	80	61359
5.00	7.0	4.70	15.5	6	80	61360
6.00	9.0	5.70	19.0	6	80	61361
8.00	12.0	7.50	25.0	8	90	61362
10.00	15.0	9.50	31.0	10	110	61363
12.00	18.0	11.50	37.0	12	120	61364

Acier fort. allié

Acier Fontes 45-65 HRC

Super alliages Ni / Co



DIXI 7033

FRAISES HÉMISPHERIQUES

Z = 3



P. 174

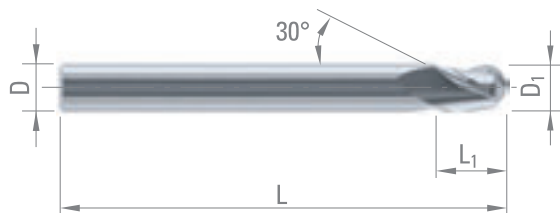

Acier + Pb	Acier faibl. allié	Acier fort. allié	Acier inox aust.	Fontes
Super alliages Ni / Co	Titane, alliage de titane	Alliage Cu Argent Or	Alu	Plastique

D ₁	L ₁	D _{h5}	L	CARBURE	TiAIN
1.00	2.0	3	38	45950	56154
1.50	2.5	3	38	45230	56155
2.00	3.0	3	38	45231	56156
2.50	4.0	3	38	45232	56157
3.00	5.0	3	38	43637	56158
4.00	6.0	4	50	43638	56159
5.00	8.0	5	50	43639	56162
6.00	9.0	6	57	42993	56163
8.00	12.0	8	63	32969	56165
10.00	15.0	10	72	32970	56166
12.00	18.0	12	73	32971	56167

DIXI 7034

FRAISES HÉMISPHERIQUES

Z = 4



P. 174

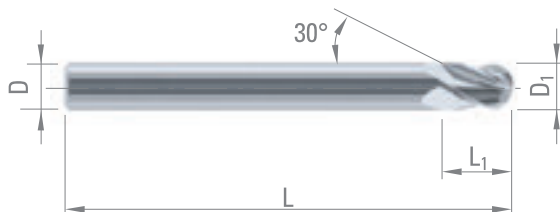

Acier + Pb	Acier faibl. allié	Acier fort. allié	Acier inox aust.	Fontes
Super alliages Ni / Co	Titane, alliage de titane	Alliage Cu Argent Or	Alliage Cu difficile	Alu
Plastique				

D _{1 e8}	L ₁	D _{h5}	L	CARBURE	TiAIN
6.00	9	6	57	43640	56142
8.00	12	8	63	43641	56143
10.00	15	10	72	32974	56144
12.00	18	12	73	32975	56149
14.00	21	14	75	32976	
16.00	24	16	82	42827	56151
20.00	30	20	104	35740	



DIXI 72420

FRAISES EN BOUT
AVEC COUPE AU CENTRE
ET TROUS DE LUBRICATION

Z = 1-2



P. 380



$D_1 \geq \varnothing 6$

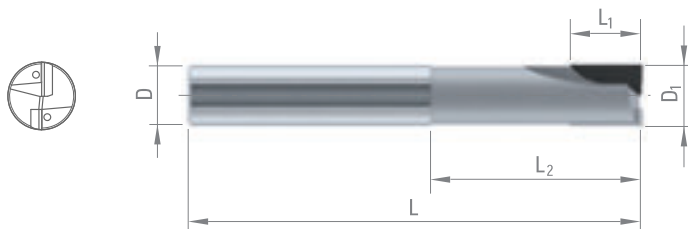

- Alliage Cu
Argent
Or
- Alliage
Cu
difficile
- Alu
- Graphite
- Carbure
Céramique
verte
- Plastique
- Fibre de
carbone

D_{1h10}	L_1	L_2	D_{h5}	L	Z	PCD	CVD
1.00	2.0	-	6	42	1	979179	
1.50	3.0	-	6	42	1	977382	
2.00	3.0	6	6	42	1	66785	
2.00 >	3.0	20	6	75	1	970175	
3.00	4.0	6	6	42	1	67540	301958
3.00 >	4.0	6	6	42	2		305549
3.00 >	4.0	15	6	75	2	970176	
3.00 >	4.0	20	6	75	2	970177	
4.00	4.0	8	6	50	1	957593	
4.00 >	6.5	10	6	50	1	67541	301959
4.00 >	6.5	15	6	75	2	970178	
4.00 >	6.5	25	6	75	2	970179	
5.00	5.0	10	6	50	2	957595	
5.00 >	6.5	10	6	50	2	53153	
5.00 >	6.5	35	6	75	2	970166	301960
6.00	6.0	12	6	57	2	976391	301961
6.00 >	8.0	34	6	75	2	976392	
6.00 >	8.0	50	6	100	2	976393	
7.00	8.0	34	8	75	2	976394	301962
8.00	7.0	14	8	63	2	976395	301963
8.00 >	10.0	34	8	75	2	976396	
8.00 >	10.0	50	8	100	2	976397	
8.00 >	10.0	75	8	125	2	976398	
9.00	10.0	35	10	75	2	976399	
10.00	8.0	16	10	75	2	976410	301965
10.00 >	12.0	35	10	75	2	976411	
10.00 >	12.0	75	10	125	2	976412	
11.00	12.0	38	12	83	2	976413	
12.00	10.0	20	12	83	2	976414	301966
12.00 >	12.0	38	12	83	2	976415	
12.00 >	12.0	75	12	125	2	976416	
14.00	12.0	24	14	83	2	976417	
14.00 >	12.0	38	14	83	2	976418	
14.00 >	12.0	75	14	125	2	976419	
16.00	14.0	28	16	92	2	976420	
16.00 >	14.0	42	16	92	2	976421	
16.00 >	14.0	75	16	125	2	976422	
20.00	18.0	36	20	104	2	976423	
20.00 >	18.0	50	20	125	2	976424	

Sur demande

CBN ▲

Aciers
Fontes
45-65 HRC

Fontes

Sur demande

Sur demande



DIXI 70520 PCD

FRAISES TORIQUES
AVEC COUPE AU CENTRE
ET TROUS DE LUBRICATION

Z = 1-2

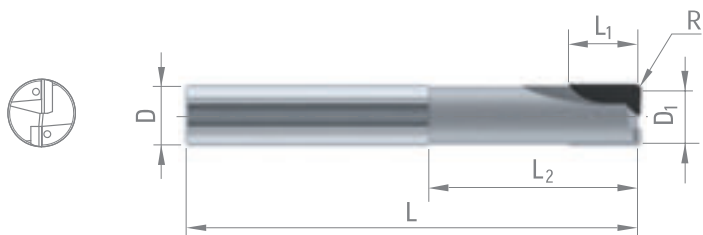
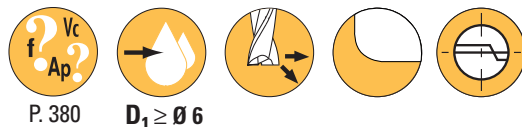

Alliage Cu Argent Or	Alliage Cu difficile	Alu	Graphite	Carbure Céramique verte
Plastique	Fibre de carbone			

D _{1h10}	L ₁	L ₂	D _{h5}	L	R	Z	PCD
1.00	2.0	-	6	42	0.1	1	984384
2.00	3.0	6	6	42	0.1	1	967923
2.00 >	3.0	6	6	42	0.2	1	973528
3.00	4.0	15	6	75	0.1	2	987438
3.00 >	4.0	15	6	75	0.3	2	305810
4.00	4.0	8	6	50	0.1	1	967925
4.00 >	6.5	10	6	50	0.5	2	971465
4.00 >	6.5	15	6	75	0.1	2	305811
4.00 >	6.5	15	6	75	0.5	2	302378
5.00	5.0	10	6	50	0.1	2	305812
5.00 >	5.0	10	6	50	0.5	2	975839
6.00	6.0	12	6	57	0.1	2	967926
6.00 >	6.0	12	6	57	0.5	2	968992
6.00 >	8.0	34	6	75	0.1	2	995208
6.00 >	8.0	34	6	75	0.5	2	974475
6.00 >	8.0	34	6	75	1.0	2	974476
8.00	7.0	14	8	63	0.1	2	967927
8.00 >	10.0	34	8	75	0.5	2	974477
8.00 >	10.0	34	8	75	1.0	2	974478
10.00	12.0	35	10	75	0.1	2	953153
10.00 >	12.0	35	10	75	0.5	2	974479
10.00 >	12.0	35	10	75	1.0	2	974480
10.00 >	12.0	75	10	125	0.5	2	974482
10.00 >	12.0	75	10	125	1.0	2	974481
12.00	10.0	20	12	83	0.1	2	984083
12.00 >	12.0	38	12	83	0.5	2	974483
12.00 >	12.0	38	12	83	1.0	2	974484
12.00 >	12.0	75	12	125	0.5	2	974485
12.00 >	12.0	75	12	125	1.0	2	974486
14.00	12.0	24	14	83	0.1	2	305814
14.00 >	12.0	24	14	83	0.5	2	305816
14.00 >	12.0	24	14	83	1.0	2	305817
16.00	14.0	28	16	92	0.1	2	993052
16.00 >	14.0	42	16	92	0.5	2	305818
16.00 >	14.0	42	16	92	1.0	2	305139
20.00	18.0	36	20	104	0.1	2	987718
20.00 >	18.0	36	20	104	0.5	2	305919
20.00 >	18.0	36	20	104	1.0	2	305820

CVD ■

Alliage Cu Argent Or	Alliage Cu difficile	Alu	Graphite
Carbure Céramique verte	Plastique	Fibre de carbone	

Sur demande

CBN ▲

Aciers Fontes 45-65 HRC	Fontes
-------------------------------	--------



DIXI 70600 PCD

FRAISES À DENTURE DROITE
AVEC COUPE AU CENTRE

Z = 1

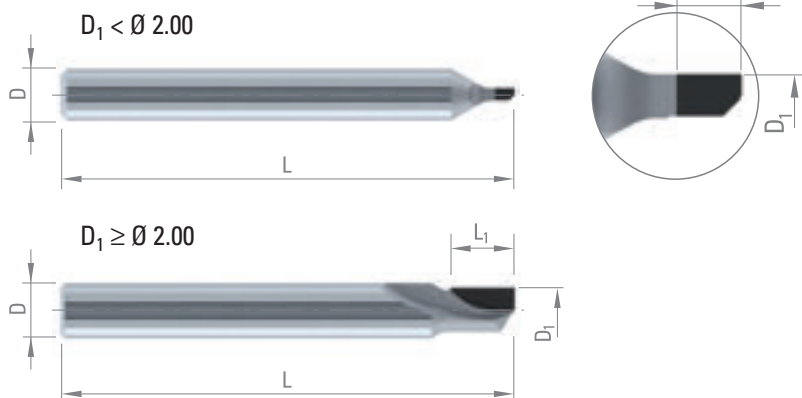

P. 380



Alliage Cu
Argent
Or

Alliage
Cu
difficile

Alu

Graphite

Carbure
Céramique
verte

Plastique

Fibre de
carbone

D_{1h10}	L_1	D_{h5}	L	PCD
1.00	2.0	6	35	302387
2.00	3.0	6	35	302388
3.00	4.0	6	42	302389
4.00	6.5	6	42	302390
5.00	6.5	6	50	302391
6.00	8.0	6	50	302393

DIXI 70600 DIA

FRAISES EN BOUT
DIAMANT MONOCRISTALLIN
AVEC COUPE AU CENTRE

Z = 1

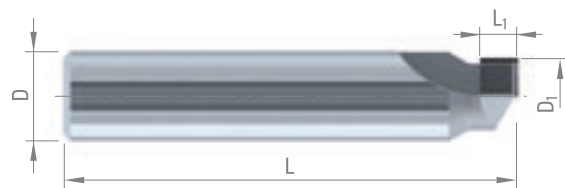

P. 380



Alliage Cu
Argent
Or

Alliage
Cu
difficile

Alu

D_1	L_1	D_{h5}	L	DIA
3.00	2.5	6	30	302394
4.00	2.5	6	30	302395
5.00	2.5	6	30	302396
6.00	2.5	6	30	302397

DIXI 72310 DIA

MICRO-FRAISES
DIAMANT MONOCRISTALLIN

Z = 1

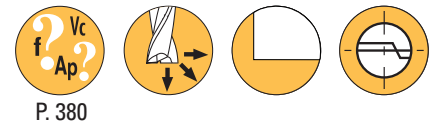

P. 380

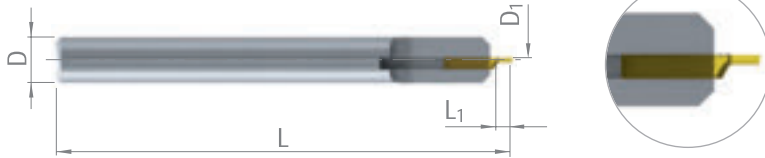

- Alliage Cu
Argent
Or
- Alliage
Cu
difficile
- Alu
- Plastique

D ₁	L ₁	D _{h5}	L	DIA
0.30	0.6	3	30	953423
0.40	0.8	3	30	953424
0.50	1.0	3	30	953425
0.60	1.2	3	30	953426
0.70	1.4	3	30	953427
0.80	1.6	3	30	953428
0.90	1.8	3	30	953429
1.00	2.5	3	30	953430
1.10	2.5	3	30	953431
1.20	2.5	3	30	953432
1.30	2.5	3	30	953433
1.40	2.5	3	30	953434
1.50	2.5	3	30	953435
1.60	2.5	3	30	953436
1.70	2.5	3	30	953437
1.80	2.5	3	30	953438
1.90	2.5	3	30	953439
2.00	2.5	6	30	953440

Corps acier

Lors de la commande, il conviendra d'indiquer la matière à usiner (non-ferreuse).



DIXI 72421 DIA

FRAISES EN BOUT
DIAMANT MONOCRISTALLIN
POUR ACRYLIQUE

Z = 1



P. 380

Plastique

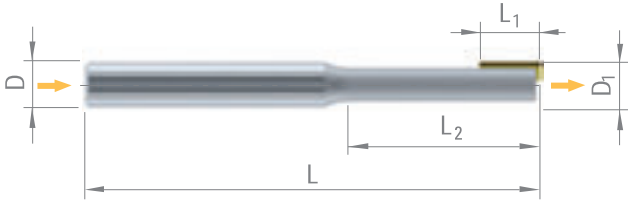

D_1	L_1	L_2	D_{h5}	L	DIA
6.00	4	25	6	57	970120
6.00	6	25	6	57	970122
6.00	8	25	6	57	974360
8.00	4	25	8	63	970126
8.00	6	25	8	63	970128
8.00	8	25	8	63	970129
10.00	4	25	10	75	974317
10.00	6	25	10	75	974318
10.00	8	25	10	75	974319
12.00	4	25	12	83	974321
12.00	6	25	12	83	974322
12.00	8	25	12	83	974323

DIXI 70320 PCD

FRAISES HÉMISPHÉRIQUES AVEC TROUS DE LUBRICATION

Z = 1-2



P. 380



$D_1 \geq \emptyset 6$

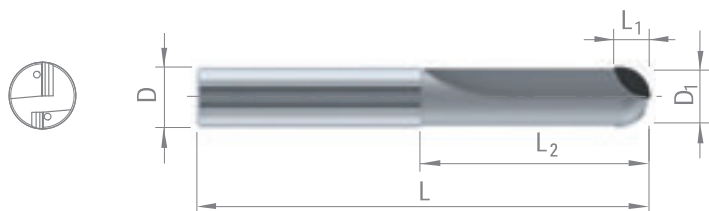

- Alliage Cu Argent Or
- Alliage Cu difficile
- Alu
- Graphite
- Plastique

$D_{1\ h10}$	L_1	L_2	D	L	Z	PCD
2.00	2.0	6.0	6	42	1	953442
2.00	2.0	25.0	6	75	1	970874
3.00	2.5	6.0	6	42	1	953443
3.00	2.5	25.0	6	75	1	970875
3.00	2.5	25.0	6	75	2	970876
4.00	3.0	8.0	6	50	1	959468
4.00	3.0	10.0	6	50	1	953444
4.00	3.0	10.0	6	50	2	970877
4.00	3.0	25.0	6	75	2	970878
4.00	3.0	35.0	6	75	2	981585
5.00	4.0	10.0	6	50	2	953445
5.00	4.0	25.0	6	75	2	970883
6.00	4.0	12.0	6	57	2	976433
6.00	4.0	34.0	6	75	2	976434
6.00	4.0	50.0	6	100	2	976435
8.00	5.0	14.0	8	63	2	976436
8.00	5.0	34.0	8	75	2	976437
8.00	5.0	75.0	8	125	2	976438
10.00	6.0	16.0	10	72	2	976439
10.00	6.0	35.0	10	75	2	976440
10.00	6.0	75.0	10	125	2	976441
12.00	7.0	20.0	12	83	2	976442
12.00	7.0	38.0	12	83	2	976443
12.00	7.0	75.0	12	125	2	976444
14.00	8.0	24.0	16	83	2	305821
16.00	9.0	28.0	16	92	2	300800
20.00	11.0	36.0	20	104	2	305822

CVD

- Alliage Cu Argent Or
- Alliage Cu difficile
- Alu
- Graphite
- Carbure Céramique verte
- Plastique
- Fibre de carbone

Sur demande

CBN

- Aciers Fontes 45-65 HRC
- Fontes

DIXI 76230 DIA

FRAISES À ANGLER
DIAMANT MONOCRISTALLIN

Z = 1

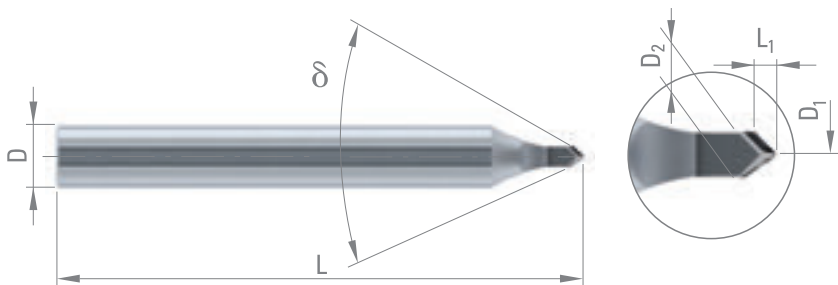
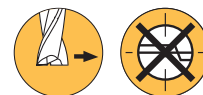

Alliage Cu Argent Or	Alliage Cu difficile	Alu	Plastique
----------------------------	----------------------------	-----	-----------

D ₁	L ₁	D ₂	δ	D _{h5}	L	DIA
* 0.10	1.40	3	60°	6	50	302596
* 0.10	0.80	3	90°	6	50	302595
* 0.30	2.80	2	30°	6	50	978382
* 0.30	1.30	3	60°	6	50	978381
* 0.30	0.70	3	90°	6	50	977871

* non coupant

DIXI 7623

FRAISES À ANGLER

Z = 3



P. 184

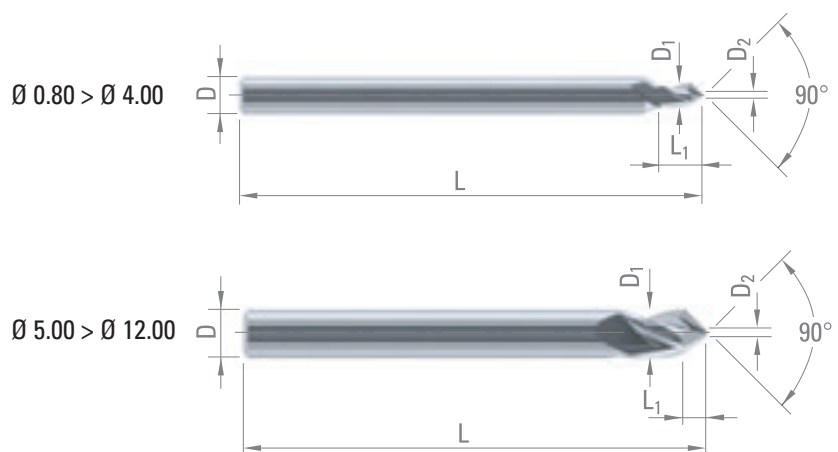

D₁ e8
Ø < 2.00 - 0/-0.01
Ø < 3.00 - 0/-0.02
Ø < 5.00 - e8

L₁ D₂ ± 0.05 D_{h5} L CARBURE TiAIN

0.80	1.5	0.08	3	38	956868	956870
1.00	2.0	0.10	3	38	956867	956869
2.00	3.0	0.20	3	38	956865	956866
3.00	5.0	0.30	3	38	956861	956862
4.00	6.0	0.40	4	50	956863	956864

D ₁ h5	L ₁	D ₂ ± 0.05	D _{h5}	L	CARBURE	TiAIN
5.00	2.25	0.50	5	50	49019	952294
6.00	2.7	0.60	6	57	49020	63603
8.00	3.6	0.80	8	63	49021	950927
10.00	4.5	1.00	10	72	49022	63604
12.00	5.4	1.20	12	73	49023	952295

Acier + Pb	Acier faibl. allié	Acier fort. allié	Acier inox aust.	Fontes
Super alliages Ni / Co	Titane, alliage de titane	Alliage Cu Argent Or	Alliage Cu difficile	Alu
Plastique				



DIXI 7624

FRAISES À ANGLER BICONIQUE

Z = 1-4



P. 184

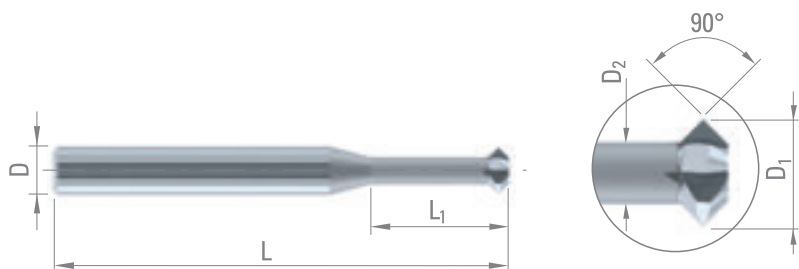
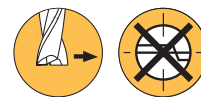

Acier + Pb	Acier faibl. allié	Acier fort. allié	Acier inox aust.	Fontes
Super alliages Ni / Co	Titane, alliage de titane	Alliage Cu Argent Or	Alliage Cu difficile	Alu
Plastique				

D ₁	L ₁	D ₂	ch	D _{h5}	L	Z	CARBURE
0.20	0.4	0.12	0.04	3	38	1	997990
0.25	0.5	0.15	0.05	3	38	1	997991
0.30	0.6	0.18	0.06	3	38	1	997992
0.40	0.8	0.24	0.08	3	38	1	997993
0.50	1.0	0.30	0.10	3	38	1	997994
0.60	1.2	0.36	0.12	3	38	3	997995
0.70	1.4	0.42	0.14	3	38	3	997996
0.80	1.6	0.48	0.16	3	38	3	997997
0.90	1.8	0.54	0.18	3	38	3	997998
1.00	2.0	0.60	0.20	3	38	3	997999
1.20	2.4	0.70	0.25	3	38	4	998000
1.30	2.6	0.70	0.30	3	38	4	998001
1.80	5.4	1.00	0.40	3	38	4	998002
2.80	8.4	1.60	0.60	3	38	4	998003
3.70	11.1	2.10	0.80	6	57	4	998004
5.70	17.1	3.30	1.20	6	57	4	998005

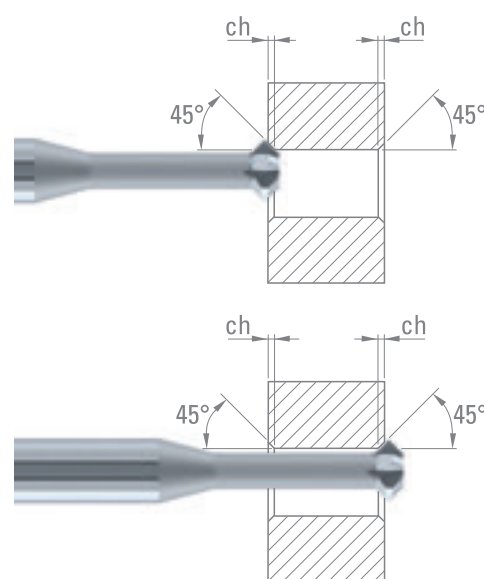

DIXI 7656

FRAISES À RAYONNER

Z = 2

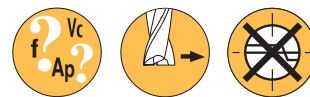

P. 184

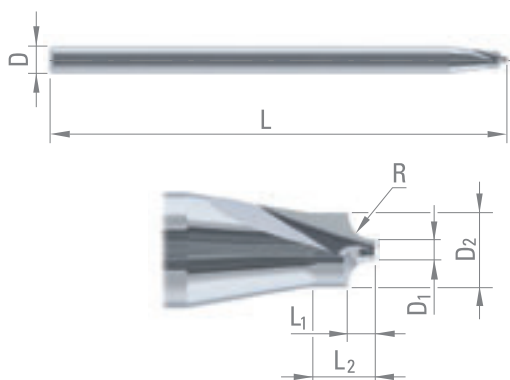

Acier + Pb	Acier faibl. allié	Acier fort. allié	Acier inox aust.	Fontes
Super alliages Ni / Co	Titane, alliage de titane	Alliage Cu Argent Or	Alliage Cu difficile	Alu
Plastique				

D ₁	L ₁	D ₂	L ₂	D _{h5}	L	R _{±0.02}	CARBURE	TiAIN
0.50	0.12	0.74	0.8	3	38	0.10	969577	969578
0.50	0.18	0.86	0.8	3	38	0.15	969586	969597
0.50	0.24	0.98	0.8	3	38	0.20	969587	969598
0.50	0.30	1.10	1.0	3	38	0.25	969588	969599
0.50	0.36	1.22	1.0	3	38	0.30	969589	969600
0.50	0.48	1.46	1.0	3	38	0.40	969590	969601
0.50	0.60	1.70	1.5	3	38	0.50	969591	969602
0.50	0.70	1.90	1.5	3	38	0.60	969592	969603
0.50	0.80	2.10	1.5	3	38	0.70	969593	969604
0.80	0.90	2.60	2.0	3	38	0.80	969594	969605
0.80	1.00	2.80	2.0	3	38	0.90	969595	969606
0.80	1.10	-	-	3	38	1.00	969596	969607

DIXI 7112

FRAISES À CONTOURNER
POUR COMPOSITES / KEVLAR®

Z = 2

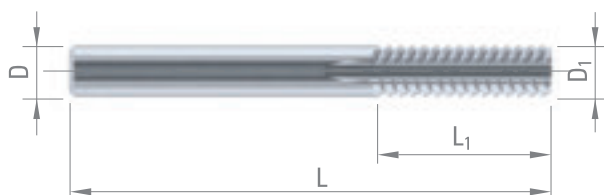

Kevlar®

CONDITIONS DE COUPE:

Contournage Vc = 250 - 500 m/min
Vf = 500 - 2000 mm/min

D ₁	inches	L ₁	D _{h5}	L	CARBURE
5.00		20	5.00	75	26252
6.00		25	6.00	75	26873
6.35	1/4"	25	6.35	75	26264
8.00		25	8.00	75	27851
10.00		25	10.00	75	28072
12.00		25	12.00	75	28073
12.70	1/2"	27	12.70	75	26254





OUTILS SUR DEMANDE

DIXI 7631 SP R L Z =



Quantités

Matière à usiner

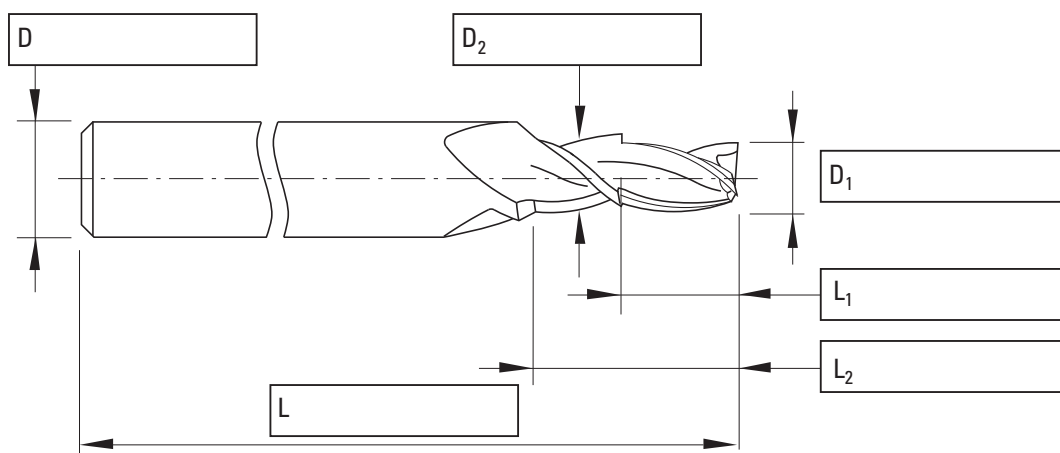

DIXI 7645 SP R L
FRAISES CONIQUES À BOUT PLAT OU HÉMISPHERIQUES

Z =

Quantités

Matière à usiner

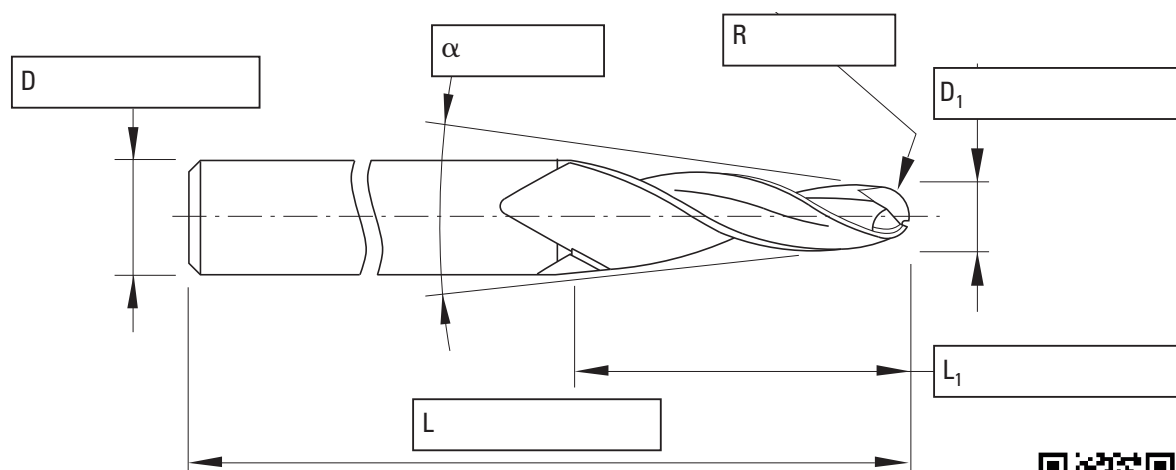
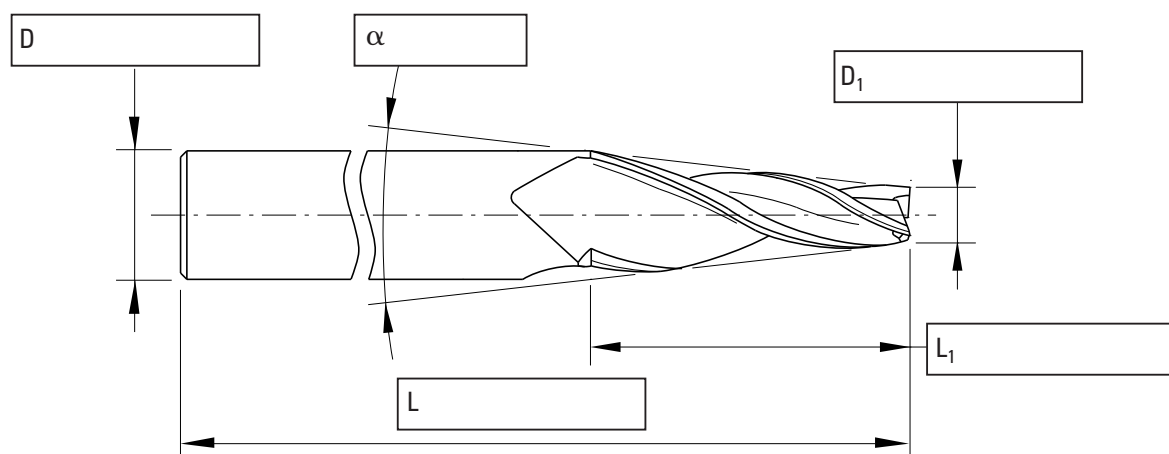

CONSULTEZ NOTRE FORMULAIRE DE DEMANDE D'OFFRES EN LIGNE SUR
WWW.DIXIPOLYTOOL.COM



CHOIX DU NOMBRE DE DENTS



1 Rainurage fermé (poche)

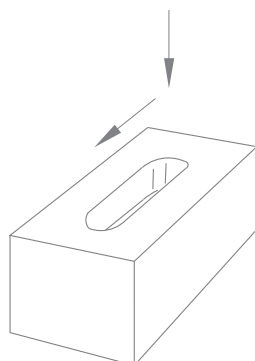

Z2



2 Rainurage fermé (ramping)

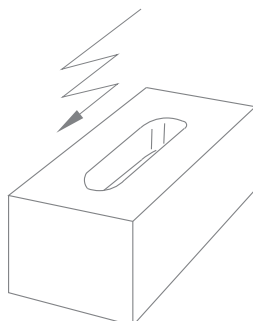

Z2 - Z3



3 Rainurage ouvert

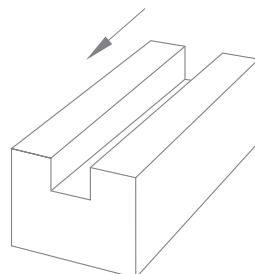

Z2 - Z3



Contournage (ébauche)

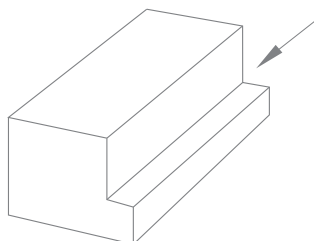

Z3 - Z4



Contournage (finition)

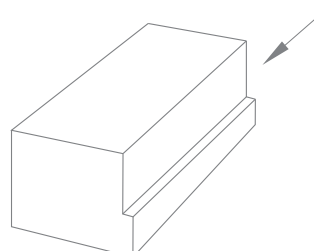

Multident



CONDITIONS DE COUPE

DIXI 7215 Z = 3 Aluminium (Vc 600 - 700 m/min)						
D	Vc [m/min]	n [min -1]	Vf [mm/min]	ap [mm]	ae [mm]	fz [mm]
6	600	31800	6200	9	3.6	0.065
8	600	23'00	6450	12	4.8	0.090
10	600	19100	6300	15	6.0	0.110
12	600	15900	6440	18	7.2	0.135
16	600	11900	6440	24	9.6	0.180

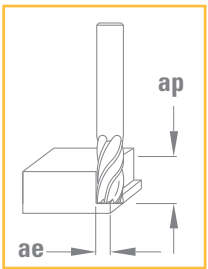

DIXI 7215 Z = 3 Cuivre (Vc 400 - 500 m/min)						
D	Vc [m/min]	n [min -1]	Vf [mm/min]	ap [mm]	ae [mm]	fz [mm]
6	400	21200	4100	9	3.6	0.065
8	400	15900	4300	12	4.8	0.090
10	400	12700	4200	15	6.0	0.110
12	400	10600	4300	18	7.2	0.135
16	400	7900	4250	24	9.6	0.180

DIXI 7215 Z = 3 Aluminium (Vc 500 - 600 m/min)						
D	Vc [m/min]	n [min -1]	Vf [mm/min]	ap [mm]	ae [mm]	fz [mm]
6	500	26500	4780	9	6	0.060
8	500	19900	4780	12	8	0.080
10	500	15900	4780	15	10	0.100
12	500	13250	4780	18	12	0.120
16	500	10000	4780	24	16	0.160

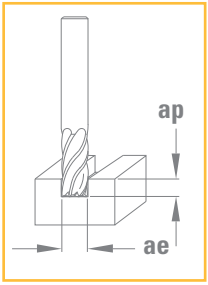

DIXI 7215 Z = 3 Cuivre (Vc 270 - 370 m/min)						
D	Vc [m/min]	n [min -1]	Vf [mm/min]	ap [mm]	ae [mm]	fz [mm]
6	270	14300	2600	9	6	0.060
8	270	10800	2600	12	8	0.080
10	270	8500	2600	15	10	0.100
12	270	7200	2600	18	12	0.120
16	270	5400	2600	24	18	0.160



CONDITIONS DE COUPE

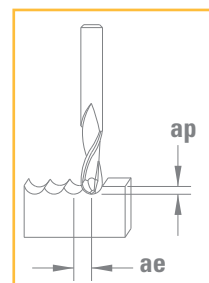

Matières à usiner

			CARBURE	DICUT	TiAIN	DIAMANT	ap [mm]	ae [mm]
			Vc [m/min]	Vc [m/min]	Vc [m/min]	Vc [m/min]		
P	Acier non allié / faiblement allié	< 600 N/mm ²	70 100		90 110		<0.15 x ØD1	<0.5 x ØD1
P	Acier non allié / faiblement allié	600 – 1500 N/mm ²			70 90		<0.15 x ØD1	<0.5 x ØD1
P	Acier de décolletage au plomb		70 100				<0.20 x ØD1	<0.5 x ØD1
P	Acier fortement allié	700 – 1500 N/mm ²			40 70		<0.15 x ØD1	<0.5 x ØD1
M	Acier inoxydable	400 – 700 N/mm ²			70 90		<0.15 x ØD1	<0.5 x ØD1
M	Acier inox. DUPLEX, acier austénitique inox. sans nickel	> 800 N/mm ²			40 70		<0.1 x ØD1	<0.4 x ØD1
K	Fonte grise / Fonte à graphite sphéroïdal perlitique	< 250 HB	70 100		90 110		<0.10 x ØD1	<0.4 x ØD1
K	Fonte allié / Fonte à graphite sphéroïdal perlitique	> 250 HB	40 70		70 90		<0.15 x ØD1	<0.5 x ØD1
K	Fonte à graphite sphéroïdal ferritique / Fonte malléable		70 100		90 110		<0.10 x ØD1	<0.4 x ØD1
S	Super alliages / Acier inox. réfractaire	Inconel Nimonic Hastelloy			25 35		<0.05 x ØD1	<0.25 x ØD1
S	Titane, alliage de titane		30 45				<0.15 x ØD1	<0.5 x ØD1
N	Alliage de cuivre / bonne usinabilité (laiton – bronze)		140 160				<0.15 x ØD1	<0.5 x ØD1
N	Alliage de cuivre / usinabilité difficile / Bronze à l'aluminium	(CuAlFe) (Ampco)	120 140	170 190	170 190		<0.15 x ØD1	<0.5 x ØD1
N	Alliage d'aluminium	Si < 8%	180 260		230 340		<0.25 x ØD1	<0.5 x ØD1
N	Fonte d'aluminium	Si > 8%	140 160		210 230		<0.25 x ØD1	<0.5 x ØD1
N	Graphite					200 300	<0.30 x ØD1	<0.6 x ØD1
N	Plastique		240 260		300 340		<0.30 x ØD1	<0.6 x ØD1
N	Or, argent		140 160		200 220		<0.15 x ØD1	<0.5 x ØD1

$$n \text{ [tr/min]} = \frac{Vc \text{ [m/min]} \times 1000}{\pi \times D_1 \text{ [mm]}}$$

$$Vf \text{ [mm/min]} = n \text{ [tr/min]} \times fz \text{ [mm]} \times Z$$

Avance par dent **fz [mm]**

$\emptyset D_1$ 0.06 - 0.60	$\emptyset D_1$ 0.60 - 1.00	$\emptyset D_1$ 1.00 - 1.50	$\emptyset D_1$ 1.50 - 3.00	$\emptyset D_1$ 3.00 - 5.00	$\emptyset D_1$ 5.00 - 7.00	$\emptyset D_1$ 7.00 - 10.00	$\emptyset D_1$ 10.00 - 14.00	$\emptyset D_1$ 14.00 - 16.00	$\emptyset D_1$ 16.00 - 20.00
0.0016 - 0.005	0.003 - 0.009	0.005 - 0.01	0.008 - 0.02	0.016 - 0.05	0.026 - 0.06	0.036 - 0.09	0.05 - 0.13	0.07 - 0.15	0.08 - 0.18
0.0012 - 0.004	0.002 - 0.007	0.004 - 0.01	0.006 - 0.02	0.012 - 0.03	0.020 - 0.05	0.027 - 0.07	0.04 - 0.09	0.05 - 0.10	0.06 - 0.13
0.0020 - 0.008	0.004 - 0.013	0.007 - 0.02	0.010 - 0.03	0.020 - 0.07	0.033 - 0.09	0.046 - 0.13	0.07 - 0.18	0.09 - 0.21	0.10 - 0.26
0.0012 - 0.004	0.002 - 0.007	0.004 - 0.01	0.006 - 0.02	0.012 - 0.03	0.020 - 0.05	0.027 - 0.07	0.04 - 0.09	0.05 - 0.10	0.06 - 0.13
0.0012 - 0.004	0.002 - 0.007	0.004 - 0.01	0.006 - 0.02	0.012 - 0.03	0.020 - 0.05	0.027 - 0.07	0.04 - 0.09	0.05 - 0.10	0.06 - 0.13
0.0012 - 0.004	0.002 - 0.007	0.004 - 0.01	0.006 - 0.02	0.012 - 0.03	0.020 - 0.05	0.027 - 0.07	0.04 - 0.09	0.05 - 0.10	0.06 - 0.13
0.0016 - 0.005	0.003 - 0.009	0.005 - 0.01	0.008 - 0.02	0.016 - 0.05	0.026 - 0.06	0.036 - 0.09	0.05 - 0.13	0.07 - 0.15	0.08 - 0.18
0.0012 - 0.004	0.002 - 0.007	0.004 - 0.01	0.006 - 0.02	0.012 - 0.03	0.020 - 0.05	0.027 - 0.07	0.04 - 0.09	0.05 - 0.10	0.06 - 0.13
0.0016 - 0.005	0.003 - 0.009	0.005 - 0.01	0.008 - 0.02	0.016 - 0.05	0.026 - 0.06	0.036 - 0.09	0.05 - 0.13	0.07 - 0.15	0.08 - 0.18
		0.004 - 0.01	0.006 - 0.02	0.012 - 0.03	0.020 - 0.05	0.027 - 0.07	0.04 - 0.09	0.05 - 0.10	0.06 - 0.13
0.0012 - 0.004	0.002 - 0.007	0.004 - 0.01	0.006 - 0.02	0.012 - 0.03	0.020 - 0.05	0.027 - 0.07	0.04 - 0.09	0.05 - 0.10	0.06 - 0.13
0.0020 - 0.008	0.004 - 0.013	0.007 - 0.02	0.010 - 0.03	0.020 - 0.07	0.033 - 0.09	0.046 - 0.13	0.07 - 0.18	0.09 - 0.21	0.10 - 0.26
0.0012 - 0.004	0.002 - 0.007	0.004 - 0.01	0.006 - 0.02	0.012 - 0.03	0.020 - 0.05	0.027 - 0.07	0.04 - 0.09	0.05 - 0.10	0.06 - 0.13
0.0020 - 0.008	0.004 - 0.013	0.007 - 0.02	0.010 - 0.03	0.020 - 0.07	0.033 - 0.09	0.046 - 0.13	0.07 - 0.18	0.09 - 0.21	0.10 - 0.26
0.0020 - 0.008	0.004 - 0.013	0.007 - 0.02	0.010 - 0.03	0.020 - 0.07	0.033 - 0.09	0.046 - 0.13	0.07 - 0.18	0.09 - 0.21	0.10 - 0.26
0.0027 - 0.012	0.005 - 0.020	0.009 - 0.03	0.014 - 0.05	0.027 - 0.10	0.046 - 0.14	0.064 - 0.20	0.09 - 0.27	0.13 - 0.31	0.15 - 0.39
0.0027 - 0.012	0.005 - 0.020	0.009 - 0.03	0.014 - 0.05	0.027 - 0.10	0.046 - 0.14	0.064 - 0.20	0.09 - 0.27	0.13 - 0.31	0.15 - 0.39
0.0020 - 0.008	0.004 - 0.013	0.007 - 0.02	0.010 - 0.03	0.020 - 0.07	0.033 - 0.09	0.046 - 0.13	0.07 - 0.18	0.09 - 0.21	0.10 - 0.26



CONDITIONS DE COUPE

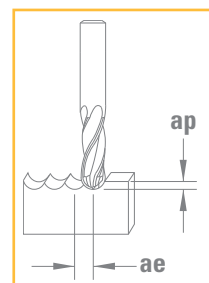

Matières à usiner

			CARBURE		TiAIN		ap [mm]	ae [mm]
			Vc [m/min]	Vc [m/min]	Vc [m/min]	Vc [m/min]		
P	Acier non allié / faiblement allié	< 600 N/mm ²	70	100	90	110	<0.15 x ØD1	<0.3 x ØD1
P	Acier non allié / faiblement allié	600 – 1500 N/mm ²			70	90	<0.15 x ØD1	<0.3 x ØD1
P	Acier de décolletage au plomb		70	100			<0.20 x ØD1	<0.3 x ØD1
P	Acier fortement allié	700 – 1500 N/mm ²			40	70	<0.10 x ØD1	<0.2 x ØD1
M	Acier inoxydable	400 – 700 N/mm ²			70	90	<0.15 x ØD1	<0.3 x ØD1
M	Acier inox. DUPLEX, acier austénitique inox. sans nickel	> 800 N/mm ²			40	70	<0.10 x ØD1	<0.2 x ØD1
K	Fonte grise / Fonte à graphite sphéroïdal perlitique	< 250 HB	70	100	90	110	<0.15 x ØD1	<0.3 x ØD1
K	Fonte allié / Fonte à graphite sphéroïdal perlitique	> 250 HB	40	70	70	90	<0.10 x ØD1	<0.2 x ØD1
K	Fonte à graphite sphéroïdal ferritique / Fonte malléable		70	100	90	110	<0.15 x ØD1	<0.3 x ØD1
S	Super alliages / Acier inox. réfractaire	Inconel Nimonic Hastelloy			25	35	<0.10 x ØD1	<0.2 x ØD1
S	Titane, alliage de titane		30	45			<0.10 x ØD1	<0.2 x ØD1
N	Alliage de cuivre / bonne usinabilité (laiton – bronze)		140	160			<0.15 x ØD1	<0.3 x ØD1
N	Alliage de cuivre / usinabilité difficile / Bronze à l'aluminium (CuAlFe) (Ampco)		120	140	170	190	<0.15 x ØD1	<0.3 x ØD1
N	Alliage d'aluminium	Si < 8%	180	260	230	340	<0.25 x ØD1	<0.3 x ØD1
N	Fonte d'aluminium	Si > 8%	140	160	210	230	<0.25 x ØD1	<0.3 x ØD1
N	Plastique		240	260	300	340	<0.30 x ØD1	<0.4 x ØD1
N	Or, argent		140	160	200	220	<0.15 x ØD1	<0.3 x ØD1

$$n \text{ [tr/min]} = \frac{V_c \text{ [m/min]} \times 1000}{\pi \times D_1 \text{ [mm]}}$$

$$V_f \text{ [mm/min]} = n \text{ [tr/min]} \times f_z \text{ [mm]} \times Z$$

Avance par dent **fz [mm]**

$\emptyset D_1$ 0.20 - 0.60	$\emptyset D_1$ 0.60 - 1.00	$\emptyset D_1$ 1.00 - 1.50	$\emptyset D_1$ 1.50 - 3.00	$\emptyset D_1$ 3.00 - 5.00	$\emptyset D_1$ 5.00 - 7.00	$\emptyset D_1$ 7.00 - 10.00	$\emptyset D_1$ 10.00 - 12.00	$\emptyset D_1$ 12.00 - 20.00
0.005 - 0.01	0.008 - 0.02	0.016 - 0.05	0.026 - 0.06	0.036 - 0.09	0.05 - 0.13	0.07 - 0.15	0.08 - 0.18	0.11 - 0.22
0.004 - 0.01	0.006 - 0.02	0.012 - 0.03	0.020 - 0.05	0.027 - 0.07	0.04 - 0.09	0.05 - 0.10	0.06 - 0.13	0.09 - 0.17
0.007 - 0.02	0.010 - 0.03	0.020 - 0.07	0.033 - 0.09	0.046 - 0.13	0.07 - 0.18	0.09 - 0.21	0.10 - 0.26	0.13 - 0.29
0.004 - 0.01	0.006 - 0.02	0.012 - 0.03	0.020 - 0.05	0.027 - 0.07	0.04 - 0.09	0.05 - 0.10	0.06 - 0.13	0.09 - 0.17
0.004 - 0.01	0.006 - 0.02	0.012 - 0.03	0.020 - 0.05	0.027 - 0.07	0.04 - 0.09	0.05 - 0.10	0.06 - 0.13	0.09 - 0.17
0.004 - 0.01	0.006 - 0.02	0.012 - 0.03	0.020 - 0.05	0.027 - 0.07	0.04 - 0.09	0.05 - 0.10	0.06 - 0.13	0.09 - 0.17
0.005 - 0.01	0.008 - 0.02	0.016 - 0.05	0.026 - 0.06	0.036 - 0.09	0.05 - 0.13	0.07 - 0.15	0.08 - 0.18	0.11 - 0.21
0.004 - 0.01	0.006 - 0.02	0.012 - 0.03	0.020 - 0.05	0.027 - 0.07	0.04 - 0.09	0.05 - 0.10	0.06 - 0.13	0.09 - 0.17
0.005 - 0.01	0.008 - 0.02	0.016 - 0.05	0.026 - 0.06	0.036 - 0.09	0.05 - 0.13	0.07 - 0.15	0.08 - 0.18	0.11 - 0.21
0.004 - 0.01	0.006 - 0.02	0.012 - 0.03	0.020 - 0.05	0.027 - 0.07	0.04 - 0.09	0.05 - 0.10	0.06 - 0.13	0.09 - 0.17
0.004 - 0.01	0.006 - 0.02	0.012 - 0.03	0.020 - 0.05	0.027 - 0.07	0.04 - 0.09	0.05 - 0.10	0.06 - 0.13	0.09 - 0.17
0.007 - 0.02	0.010 - 0.03	0.020 - 0.07	0.033 - 0.09	0.046 - 0.13	0.07 - 0.18	0.09 - 0.21	0.10 - 0.26	0.13 - 0.29
0.004 - 0.01	0.006 - 0.02	0.012 - 0.03	0.020 - 0.05	0.027 - 0.07	0.04 - 0.09	0.05 - 0.10	0.06 - 0.13	0.09 - 0.17
0.007 - 0.02	0.010 - 0.03	0.020 - 0.07	0.033 - 0.09	0.046 - 0.13	0.07 - 0.18	0.09 - 0.21	0.10 - 0.26	0.13 - 0.29
0.007 - 0.02	0.010 - 0.03	0.020 - 0.07	0.033 - 0.09	0.046 - 0.13	0.07 - 0.18	0.09 - 0.21	0.10 - 0.26	0.13 - 0.29
0.009 - 0.03	0.014 - 0.05	0.027 - 0.10	0.046 - 0.14	0.064 - 0.20	0.09 - 0.27	0.13 - 0.31	0.15 - 0.39	0.18 - 0.42
0.007 - 0.02	0.010 - 0.03	0.020 - 0.07	0.033 - 0.09	0.046 - 0.13	0.07 - 0.18	0.09 - 0.21	0.10 - 0.26	0.13 - 0.29



CONDITIONS DE COUPE

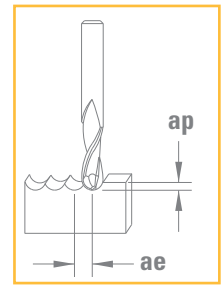

Matières à usiner

			CARBURE	DICUT	TiAIN	DIAMANT	ap [mm]	ae [mm]
			Vc [m/min]	Vc [m/min]	Vc [m/min]	Vc [m/min]		
P	Acier non allié / faiblement allié	< 600 N/mm ²	70 100		90 110		<0.15 x ØD1	<0.5 x ØD1
P	Acier non allié / faiblement allié	600 – 1500 N/mm ²			70 90		<0.15 x ØD1	<0.5 x ØD1
P	Acier de décolletage au plomb		70 100				<0.20 x ØD1	<0.5 x ØD1
P	Acier fortement allié	700 – 1500 N/mm ²			40 70		<0.10 x ØD1	<0.4 x ØD1
M	Acier inoxydable	400 – 700 N/mm ²			70 90		<0.15 x ØD1	<0.5 x ØD1
M	Acier inox. DUPLEX, acier austénitique inox. sans nickel	> 800 N/mm ²			40 70		<0.10 x ØD1	<0.4 x ØD1
K	Fonte grise / Fonte à graphite sphéroïdal perlitique	< 250 HB	70 100		90 110		<0.15 x ØD1	<0.5 x ØD1
K	Fonte alliée / Fonte à graphite sphéroïdal perlitique	> 250 HB	40 70		70 90		<0.10 x ØD1	<0.4 x ØD1
K	Fonte à graphite sphéroïdal ferritique / Fonte malléable		70 100		90 110		<0.15 x ØD1	<0.5 x ØD1
S	Super alliages / Acier inox. réfractaire	Inconel Nimonic Hastelloy			25 35		< 0.10 x ØD1	<.0.10 x ØD1
S	Titane, alliage de titane		30 45				<0.10 x ØD1	<0.4 x ØD1
N	Alliage de cuivre / bonne usinabilité (laiton – bronze)		140 160				<0.15 x ØD1	<0.5 x ØD1
N	Alliage de cuivre / usinabilité difficile / Bronze à l'aluminium (CuAlFe) (Ampco)		120 140	170 190	170 190		<0.15 x ØD1	<0.5 x ØD1
N	Alliage d'aluminium	Si < 8%	180 240		230 340		<0.25 x ØD1	<0.5 x ØD1
N	Fonte d'aluminium	Si > 8%	140 160			200 300	<0.25 x ØD1	<0.5 x ØD1
N	Graphite					200 300	<0.30 x ØD1	<0.6 x ØD1
N	Plastique		240 260		300 340		<0.30 x ØD1	<0.6 x ØD1
N	Or, argent		140 160		200 220		<0.15 x ØD1	<0.5 x ØD1

n et Vf sont indicatifs et devront être ajustées en fonction de la longueur L₂ de l'outil



$$n \text{ [tr/min]} = \frac{V_c \text{ [m/min]} \times 1000}{\pi \times D_1 \text{ [mm]}}$$

$$V_f \text{ [mm/min]} = n \text{ [tr/min]} \times f_z \text{ [mm]} \times Z$$

Avance par dent **fz [mm]**

$\emptyset D_1$ 0.20 - 0.60	$\emptyset D_1$ 0.60 - 1.00	$\emptyset D_1$ 1.00 - 1.50	$\emptyset D_1$ 1.50 - 3.00	$\emptyset D_1$ 3.00 - 5.00	$\emptyset D_1$ 5.00 - 7.00	$\emptyset D_1$ 7.00 - 10.00	$\emptyset D_1$ 10.00 - 12.00
0.0014 - 0.005	0.003 - 0.008	0.005 - 0.01	0.007 - 0.02	0.014 - 0.04	0.023 - 0.06	0.032 - 0.08	0.05 - 0.11
0.0010 - 0.003	0.002 - 0.006	0.003 - 0.01	0.005 - 0.015	0.010 - 0.03	0.017 - 0.04	0.024 - 0.06	0.03 - 0.08
0.0017 - 0.007	0.003 - 0.012	0.006 - 0.02	0.009 - 0.03	0.017 - 0.06	0.029 - 0.08	0.040 - 0.12	0.06 - 0.16
0.0010 - 0.003	0.002 - 0.006	0.003 - 0.01	0.005 - 0.015	0.010 - 0.03	0.017 - 0.04	0.024 - 0.06	0.03 - 0.08
0.0010 - 0.003	0.002 - 0.006	0.003 - 0.01	0.005 - 0.015	0.010 - 0.03	0.017 - 0.04	0.024 - 0.06	0.03 - 0.08
0.0010 - 0.003	0.002 - 0.006	0.003 - 0.01	0.005 - 0.015	0.010 - 0.03	0.017 - 0.04	0.024 - 0.06	0.03 - 0.08
0.0014 - 0.005	0.003 - 0.008	0.005 - 0.01	0.007 - 0.02	0.014 - 0.04	0.023 - 0.06	0.032 - 0.08	0.05 - 0.11
0.0010 - 0.003	0.002 - 0.006	0.003 - 0.01	0.005 - 0.015	0.010 - 0.03	0.017 - 0.04	0.024 - 0.06	0.03 - 0.08
0.0014 - 0.005	0.003 - 0.008	0.005 - 0.01	0.007 - 0.02	0.014 - 0.04	0.023 - 0.06	0.032 - 0.08	0.05 - 0.11
		0.003 - 0.01	0.005 - 0.015	0.010 - 0.03	0.017 - 0.04	0.024 - 0.06	0.03 - 0.08
0.0010 - 0.003	0.002 - 0.006	0.003 - 0.01	0.005 - 0.015	0.010 - 0.03	0.017 - 0.04	0.024 - 0.06	0.03 - 0.08
0.0017 - 0.007	0.003 - 0.012	0.006 - 0.02	0.009 - 0.03	0.017 - 0.06	0.029 - 0.08	0.040 - 0.12	0.06 - 0.16
0.0010 - 0.003	0.002 - 0.006	0.003 - 0.01	0.005 - 0.015	0.010 - 0.03	0.017 - 0.04	0.024 - 0.06	0.03 - 0.08
0.0017 - 0.007	0.003 - 0.012	0.006 - 0.02	0.009 - 0.03	0.017 - 0.06	0.029 - 0.08	0.040 - 0.12	0.06 - 0.16
0.0017 - 0.007	0.003 - 0.012	0.006 - 0.02	0.009 - 0.03	0.017 - 0.06	0.029 - 0.08	0.040 - 0.12	0.06 - 0.16
0.0024 - 0.010	0.005 - 0.017	0.008 - 0.03	0.012 - 0.04	0.024 - 0.09	0.040 - 0.12	0.056 - 0.17	0.08 - 0.24
0.0024 - 0.010	0.005 - 0.017	0.008 - 0.03	0.012 - 0.04	0.024 - 0.09	0.040 - 0.12	0.056 - 0.17	0.08 - 0.24
0.0017 - 0.007	0.003 - 0.012	0.006 - 0.02	0.009 - 0.03	0.017 - 0.06	0.029 - 0.08	0.040 - 0.12	0.06 - 0.16



CONDITIONS DE COUPE

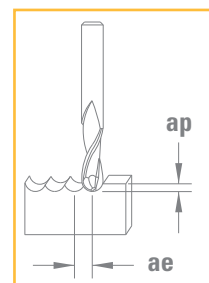

Matières à usiner

			CARBURE		TiAlN		DIAMANT		ap [mm]	ae [mm]
			Vc [m/min]		Vc [m/min]		Vc [m/min]			
P	Acier non allié / faiblement allié	< 600 N/mm ²	60	90	80	100			<0.10 x ØD1	<0.3 x ØD1
P	Acier non allié / faiblement allié	600 – 1500 N/mm ²			60	80			<0.10 x ØD1	<0.3 x ØD1
P	Acier de décolletage au plomb		60	90	80	100			<0.15 x ØD1	<0.3 x ØD1
P	Acier fortement allié	700 – 1500 N/mm ²			30	60			<0.05 x ØD1	<0.2 x ØD1
M	Acier inoxydable	400 – 700 N/mm ²			60	80			<0.10 x ØD1	<0.3 x ØD1
M	Acier inox. DUPLEX, acier austénitique inox. sans nickel	> 800 N/mm ²			30	60			<0.05 x ØD1	<0.2 x ØD1
K	Fonte grise / Fonte à graphite sphéroïdal perlitique	< 250 HB	60	90	80	100			<0.10 x ØD1	<0.3 x ØD1
K	Fonte allée / Fonte à graphite sphéroïdal perlitique	> 250 HB	30	50	60	80			<0.05 x ØD1	<0.2 x ØD1
K	Fonte à graphite sphéroïdal ferritique / Fonte malléable		60	90	80	100			<0.10 x ØD1	<0.3 x ØD1
S	Super alliages / Acier inox. réfractaire	Inconel Nimonic Hastelloy			20	30			<0.05 x ØD1	<0.2 x ØD1
S	Titane, alliage de titane		25	35	30	50			<0.05 x ØD1	<0.2 x ØD1
N	Alliage de cuivre / bonne usinabilité (laiton – bronze)		100	130	140	180			<0.10 x ØD1	<0.3 x ØD1
N	Alliage de cuivre / usinabilité difficile / Bronze à l'aluminium	(CuAlFe) (Ampco)	90	110	130	160			<0.10 x ØD1	<0.3 x ØD1
N	Alliage d'aluminium	Si < 8%	130	180	150	250			<0.20 x ØD1	<0.3 x ØD1
N	Fonte d'aluminium	Si > 8%	100	130			200	300	<0.20 x ØD1	<0.3 x ØD1
N	Graphite						200	300	<0.25 x ØD1	<0.4 x ØD1
N	Plastique		180	220	200	250			<0.25 x ØD1	<0.4 x ØD1
N	Or, argent		100	130	140	180			<0.10 x ØD1	<0.3 x ØD1

$$n \text{ [tr/min]} = \frac{V_c \text{ [m/min]} \times 1000}{\pi \times D_1 \text{ [mm]}}$$

$$V_f \text{ [mm/min]} = n \text{ [tr/min]} \times f_z \text{ [mm]} \times Z$$

Avance par dent **fz [mm]**

∅ D ₁ 2.00 - 2.50	∅ D ₁ 2.50 - 3.00	∅ D ₁ 3.00 - 4.00	∅ D ₁ 4.00 - 5.00	∅ D ₁ 5.00 - 6.00	∅ D ₁ 6.00 - 8.00	∅ D ₁ 8.00 - 10.00	∅ D ₁ 10.00 - 14.00	∅ D ₁ 14.00 - 16.00	∅ D ₁ 16.00 - 20.00
0.010 - 0.021	0.012 - 0.03	0.014 - 0.03	0.019 - 0.04	0.024 - 0.05	0.029 - 0.07	0.038 - 0.08	0.05 - 0.12	0.07 - 0.13	0.08 - 0.17
0.007 - 0.015	0.009 - 0.02	0.011 - 0.02	0.014 - 0.03	0.018 - 0.04	0.022 - 0.05	0.029 - 0.06	0.04 - 0.08	0.05 - 0.10	0.06 - 0.12
0.012 - 0.030	0.015 - 0.04	0.018 - 0.05	0.024 - 0.06	0.030 - 0.07	0.036 - 0.10	0.048 - 0.12	0.06 - 0.17	0.08 - 0.19	0.10 - 0.24
0.007 - 0.015	0.009 - 0.02	0.011 - 0.02	0.014 - 0.03	0.018 - 0.04	0.022 - 0.05	0.029 - 0.06	0.04 - 0.08	0.05 - 0.10	0.06 - 0.12
0.007 - 0.015	0.009 - 0.02	0.011 - 0.02	0.014 - 0.03	0.018 - 0.04	0.022 - 0.05	0.029 - 0.06	0.04 - 0.08	0.05 - 0.10	0.06 - 0.12
0.007 - 0.015	0.009 - 0.02	0.011 - 0.02	0.014 - 0.03	0.018 - 0.04	0.022 - 0.05	0.029 - 0.06	0.04 - 0.08	0.05 - 0.10	0.06 - 0.12
0.010 - 0.021	0.012 - 0.03	0.014 - 0.03	0.019 - 0.04	0.024 - 0.05	0.029 - 0.07	0.038 - 0.08	0.05 - 0.12	0.07 - 0.13	0.08 - 0.17
0.007 - 0.015	0.009 - 0.02	0.011 - 0.02	0.014 - 0.03	0.018 - 0.04	0.022 - 0.05	0.029 - 0.06	0.04 - 0.08	0.05 - 0.10	0.06 - 0.12
0.010 - 0.021	0.012 - 0.03	0.014 - 0.03	0.019 - 0.04	0.024 - 0.05	0.029 - 0.07	0.038 - 0.08	0.05 - 0.12	0.07 - 0.13	0.08 - 0.17
0.007 - 0.015	0.009 - 0.02	0.011 - 0.02	0.014 - 0.03	0.018 - 0.04	0.022 - 0.05	0.029 - 0.06	0.04 - 0.08	0.05 - 0.10	0.06 - 0.12
0.007 - 0.015	0.009 - 0.02	0.011 - 0.02	0.014 - 0.03	0.018 - 0.04	0.022 - 0.05	0.029 - 0.06	0.04 - 0.08	0.05 - 0.10	0.06 - 0.12
0.012 - 0.030	0.015 - 0.04	0.018 - 0.05	0.024 - 0.06	0.030 - 0.07	0.036 - 0.10	0.048 - 0.12	0.06 - 0.17	0.08 - 0.19	0.10 - 0.24
0.007 - 0.015	0.009 - 0.02	0.011 - 0.02	0.014 - 0.03	0.018 - 0.04	0.022 - 0.05	0.029 - 0.06	0.04 - 0.08	0.05 - 0.10	0.06 - 0.12
0.012 - 0.030	0.015 - 0.04	0.018 - 0.05	0.024 - 0.06	0.030 - 0.07	0.036 - 0.10	0.048 - 0.12	0.06 - 0.17	0.08 - 0.19	0.10 - 0.24
0.012 - 0.030	0.015 - 0.04	0.018 - 0.05	0.024 - 0.06	0.030 - 0.07	0.036 - 0.10	0.048 - 0.12	0.06 - 0.17	0.08 - 0.19	0.10 - 0.24
0.017 - 0.045	0.021 - 0.05	0.025 - 0.07	0.034 - 0.09	0.042 - 0.11	0.050 - 0.14	0.067 - 0.18	0.08 - 0.25	0.12 - 0.29	0.13 - 0.36
0.017 - 0.045	0.021 - 0.05	0.025 - 0.07	0.034 - 0.09	0.042 - 0.11	0.050 - 0.14	0.067 - 0.18	0.08 - 0.25	0.12 - 0.29	0.13 - 0.36
0.012 - 0.030	0.015 - 0.04	0.018 - 0.05	0.024 - 0.06	0.030 - 0.07	0.036 - 0.10	0.048 - 0.12	0.06 - 0.17	0.08 - 0.19	0.10 - 0.24



CONDITIONS DE COUPE

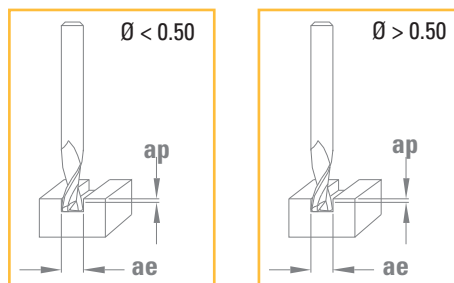

Matières à usiner

			CARBURE		TiAlN		ap [mm]	ae [mm]	ap [mm]	ae [mm]
			Vc [m/min]	Vc [m/min]	Vc [m/min]	Vc [m/min]				
P	Acier non allié / faiblement allié	< 600 N/mm ²	70	100	90	110	< 0.5 x ØD1	1 x ØD1	< 1 x ØD1	1 x ØD1
P	Acier non allié / faiblement allié	600 – 1500 N/mm ²			70	90	< 0.3 x ØD1	1 x ØD1	< 0.6 x ØD1	1 x ØD1
P	Acier de décolletage au plomb		70	100			< 0.5 x ØD1	1 x ØD1	< 1 x ØD1	1 x ØD1
P	Acier fortement allié	700 – 1500 N/mm ²			40	70	< 0.2 x ØD1	1 x ØD1	< 0.5 x ØD1	1 x ØD1
M	Acier inoxydable	400 – 700 N/mm ²			70	90	< 0.5 x ØD1	1 x ØD1	< 0.8 x ØD1	1 x ØD1
M	Acier inox. DUPLEX, acier austénitique inox. sans nickel	> 800 N/mm ²			40	70	< 0.5 x ØD1	1 x ØD1	< 0.8 x ØD1	1 x ØD1
K	Fonte grise / Fonte à graphite sphéroïdal perlitique	< 250 HB	70	100	90	110	< 0.5 x ØD1	1 x ØD1	< 1 x ØD1	1 x ØD1
K	Fonte alliée / Fonte à graphite sphéroïdal perlitique	> 250 HB	40	70	70	90	< 0.3 x ØD1	1 x ØD1	< 0.6 x ØD1	1 x ØD1
K	Fonte à graphite sphéroïdal ferritique / Fonte malléable		70	100	90	110	< 0.3 x ØD1	1 x ØD1	< 0.6 x ØD1	1 x ØD1
S	Super alliages / Acier inox. réfractaire	Inconel Nimonic Hastelloy			25	35			< 0.4 x ØD1	1 x ØD1
N	Titane, alliage de titane		30	45			< 0.3 x ØD1	1 x ØD1	< 0.5 x ØD1	1 x ØD1
N	Alliage de cuivre / bonne usinabilité (laiton – bronze)		140	160			< 0.5 x ØD1	1 x ØD1	< 1 x ØD1	1 x ØD1
N	Alliage de cuivre / usinabilité difficile / Bronze à l'aluminium (CuAlFe) (Ampco)		120	140	170	190	< 0.3 x ØD1	1 x ØD1	< 0.7 x ØD1	1 x ØD1
N	Alliage d'aluminium	Si < 8%	180	260	230	340	< 0.6 x ØD1	1 x ØD1	< 1.2 x ØD1	1 x ØD1
N	Fonte d'aluminium	Si > 8%	140	160	210	230	< 0.4 x ØD1	1 x ØD1	< 0.9 x ØD1	1 x ØD1
N	Plastique		240	260	300	340	< 0.6 x ØD1	1 x ØD1	< 1.2 x ØD1	1 x ØD1
N	Or, argent		140	160	200	220	< 0.6 x ØD1	1 x ØD1	< 0.9 x ØD1	1 x ØD1

DIXI 7202 DIAMANT

CONDITIONS DE COUPE

Matières à usiner

		DIAMANT		ap [mm]	ae [mm]
		Vc [m/min]	Vc [m/min]		
N	Graphite	200	300	< 1 x ØD1	< 1 x ØD1



$$n \text{ [tr/min]} = \frac{Vc \text{ [m/min]} \times 1000}{\pi \times D_1 \text{ [mm]}}$$

$$Vf \text{ [mm/min]} = n \text{ [tr/min]} \times fz \text{ [mm]} \times Z$$

Avance par dent **fz [mm]**

Ø D ₁ 0.04 - 0.50	Ø D ₁ 0.50 - 1.00	Ø D ₁ 1.00 - 1.50	Ø D ₁ 1.50 - 3.00	Ø D ₁ 3.00 - 5.00	Ø D ₁ 5.00 - 7.00	Ø D ₁ 7.00 - 10.00	Ø D ₁ 10.00 - 13.00	Ø D ₁ 13.00 - 16.00	Ø D ₁ 16.00 - 20.00
0.003 - 0.01	0.006 - 0.015	0.012 - 0.020	0.016 - 0.04	0.02 - 0.06	0.03 - 0.09	0.04 - 0.11	0.05 - 0.12	0.06 - 0.13	0.07 - 0.14
0.003 - 0.01	0.006 - 0.015	0.012 - 0.020	0.016 - 0.04	0.02 - 0.06	0.03 - 0.09	0.04 - 0.11	0.05 - 0.12	0.06 - 0.13	0.07 - 0.14
0.003 - 0.01	0.006 - 0.015	0.012 - 0.020	0.016 - 0.04	0.02 - 0.06	0.03 - 0.09	0.04 - 0.11	0.05 - 0.14	0.07 - 0.16	0.08 - 0.20
0.002 - 0.01	0.006 - 0.015	0.012 - 0.020	0.016 - 0.04	0.02 - 0.06	0.03 - 0.09	0.04 - 0.11	0.05 - 0.12	0.06 - 0.13	0.07 - 0.14
0.002 - 0.01	0.006 - 0.015	0.012 - 0.020	0.016 - 0.04	0.02 - 0.06	0.03 - 0.09	0.04 - 0.11	0.05 - 0.12	0.06 - 0.13	0.07 - 0.14
0.002 - 0.01	0.006 - 0.015	0.012 - 0.020	0.016 - 0.04	0.02 - 0.06	0.03 - 0.09	0.04 - 0.11	0.05 - 0.12	0.06 - 0.13	0.07 - 0.14
0.003 - 0.01	0.006 - 0.015	0.012 - 0.020	0.016 - 0.04	0.02 - 0.06	0.03 - 0.09	0.04 - 0.11	0.05 - 0.12	0.06 - 0.13	0.07 - 0.14
0.003 - 0.01	0.006 - 0.015	0.012 - 0.020	0.016 - 0.04	0.02 - 0.06	0.03 - 0.09	0.04 - 0.11	0.05 - 0.12	0.06 - 0.13	0.07 - 0.14
0.003 - 0.01	0.006 - 0.015	0.012 - 0.020	0.016 - 0.04	0.02 - 0.06	0.03 - 0.09	0.04 - 0.11	0.05 - 0.12	0.06 - 0.13	0.07 - 0.14
0.002 - 0.01	0.006 - 0.015	0.012 - 0.020	0.016 - 0.04	0.02 - 0.06	0.03 - 0.09	0.04 - 0.11	0.05 - 0.12	0.06 - 0.13	0.07 - 0.14
0.003 - 0.01	0.006 - 0.015	0.012 - 0.020	0.016 - 0.04	0.02 - 0.06	0.03 - 0.09	0.04 - 0.11	0.05 - 0.14	0.07 - 0.16	0.08 - 0.20
0.003 - 0.01	0.006 - 0.015	0.012 - 0.020	0.016 - 0.04	0.02 - 0.06	0.03 - 0.09	0.04 - 0.11	0.05 - 0.12	0.06 - 0.13	0.07 - 0.14
0.003 - 0.01	0.006 - 0.015	0.012 - 0.020	0.016 - 0.04	0.02 - 0.06	0.03 - 0.09	0.04 - 0.11	0.05 - 0.14	0.07 - 0.16	0.08 - 0.20
0.003 - 0.01	0.006 - 0.015	0.012 - 0.020	0.016 - 0.04	0.02 - 0.06	0.03 - 0.09	0.04 - 0.11	0.05 - 0.14	0.07 - 0.16	0.08 - 0.20
0.003 - 0.01	0.006 - 0.015	0.012 - 0.020	0.016 - 0.04	0.02 - 0.06	0.03 - 0.09	0.04 - 0.11	0.05 - 0.21	0.10 - 0.24	0.11 - 0.30
0.003 - 0.01	0.006 - 0.015	0.012 - 0.020	0.016 - 0.04	0.02 - 0.06	0.03 - 0.09	0.04 - 0.11	0.06 - 0.14	0.07 - 0.16	0.08 - 0.20

L'avance en plongée (V_{fp}) d'une fraise Z = 2 (perçage) doit être réduite de 40 à 80 % en fonction de la matière à usiner.

Avance par dent

Ø D ₁ 0.04 - 0.50	Ø D ₁ 0.50 - 1.00	Ø D ₁ 1.00 - 1.50	Ø D ₁ 1.50 - 3.00	Ø D ₁ 3.00 - 5.00	Ø D ₁ 5.00 - 7.00	Ø D ₁ 7.00 - 10.00	Ø D ₁ 10.00 - 13.00	Ø D ₁ 13.00 - 16.00	Ø D ₁ 16.00 - 20.00
0.003 - 0.01	0.006 - 0.015	0.012 - 0.020	0.016 - 0.04	0.02 - 0.06	0.03 - 0.09	0.04 - 0.11	0.05 - 0.14	0.07 - 0.16	0.08 - 0.20



CONDITIONS DE COUPE

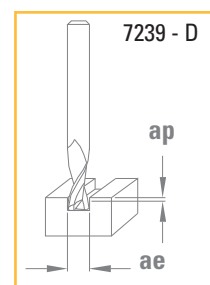
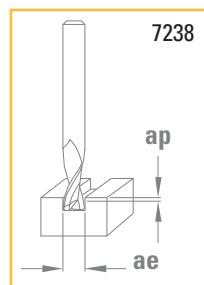

Matières à usiner

			CARBURE		TiAlN		ap [mm]	ae [mm]	ap [mm]	ae [mm]
			Vc [m/min]	Vc [m/min]	Vc [m/min]	Vc [m/min]				
P	Acier non allié / faiblement allié	< 600 N/mm ²	70	100	90	110	< 0.10 x ØD1	1 x ØD1	< 0.04 x ØD1	1 x ØD1
P	Acier non allié / faiblement allié	600 – 1500 N/mm ²			70	90	< 0.10 x ØD1	1 x ØD1	< 0.04 x ØD1	1 x ØD1
P	Acier de décolletage au plomb		70	100			< 0.12x ØD1	1 x ØD1	< 0.06 x ØD1	1 x ØD1
P	Acier fortement allié	700 – 1500 N/mm ²			40	70	< 0.10 x ØD1	1 x ØD1	< 0.04 x ØD1	1 x ØD1
M	Acier inoxydable	400 – 700 N/mm ²			70	90	< 0.10x ØD1	1 x ØD1	< 0.04 x ØD1	1 x ØD1
M	Acier inox. DUPLEX, acier austénitique inox. sans nickel	> 800 N/mm ²			40	70	< 0.10 x ØD1	1 x ØD1	< 0.04 x ØD1	1 x ØD1
K	Fonte grise / Fonte à graphite sphéroïdal perlitique	< 250 HB	70	100	90	110	< 0.10 x ØD1	1 x ØD1	< 0.04 x ØD1	1 x ØD1
K	Fonte alliée / Fonte à graphite sphéroïdal perlitique	> 250 HB	40	70	70	90	< 0.10 x ØD1	1 x ØD1	< 0.04 x ØD1	1 x ØD1
K	Fonte à graphite sphéroïdal ferritique / Fonte malléable		70	100	90	110	< 0.10 x ØD1	1 x ØD1	< 0.04 x ØD1	1 x ØD1
S	Super alliages / Acier inox. réfractaire	Inconel Nimonic Hastelloy			25	35	< 0.10 x ØD1	1 x ØD1	< 0.04 x ØD1	1 x ØD1
S	Titane, alliage de titane		30	45			< 0.10 x ØD1	1 x ØD1	< 0.04 x ØD1	1 x ØD1
N	Alliage de cuivre / bonne usinabilité (laiton – bronze)		140	160			< 0.12 x ØD1	1 x ØD1	< 0.06 x ØD1	1 x ØD1
N	Alliage de cuivre / usinabilité difficile / Bronze à l'aluminium	(CuAlFe) (Ampco)	120	140	170	190	< 0.10 x ØD1	1 x ØD1	< 0.04 x ØD1	1 x ØD1
N	Alliage d'aluminium	Si < 8%	180	260	230	340	< 0.12 x ØD1	1 x ØD1	< 0.06 x ØD1	1 x ØD1
N	Fonte d'aluminium	Si > 8%	140	160	210	230	< 0.12 x ØD1	1 x ØD1	< 0.06 x ØD1	1 x ØD1
N	Plastique		240	260	300	340	< 0.15 x ØD1	1 x ØD1	< 0.10 x ØD1	1 x ØD1
N	Or, argent		140	160	200	220	< 0.12 x ØD1	1 x ØD1	< 0.06 x ØD1	1 x ØD1

n et Vf sont indicatifs et devront être ajustées en fonction de la longueur L₂ de l'outil.

L'avance en plongée (Vfp) d'une fraise Z = 2 (perçage) doit être réduite de 40 à 80 % en fonction de la matière à usiner.



$$n \text{ [tr/min]} = \frac{V_c \text{ [m/min]} \times 1000}{\pi \times D_1 \text{ [mm]}}$$

$$V_f \text{ [mm/min]} = n \text{ [tr/min]} \times f_z \text{ [mm]} \times Z$$

Avance par dent **fz [mm]**

Ø D ₁ 0.15 - 0.30	Ø D ₁ 0.30 - 0.40	Ø D ₁ 0.40 - 0.60	Ø D ₁ 0.60 - 0.90	Ø D ₁ 0.90 - 1.20	Ø D ₁ 1.20 - 1.50	Ø D ₁ 1.50 - 1.80	Ø D ₁ 1.80 - 2.10	Ø D ₁ 2.10 - 2.50	Ø D ₁ 2.50 - 3.00
0.002 - 0.003	0.002 - 0.004	0.003 - 0.01	0.008 - 0.012	0.010 - 0.015	0.012 - 0.016	0.013 - 0.02	0.015 - 0.022	0.02 - 0.025	0.022 - 0.04
0.002 - 0.003	0.002 - 0.004	0.003 - 0.01	0.008 - 0.012	0.010 - 0.015	0.012 - 0.016	0.013 - 0.02	0.015 - 0.022	0.02 - 0.025	0.022 - 0.04
0.002 - 0.003	0.002 - 0.004	0.003 - 0.01	0.008 - 0.012	0.010 - 0.015	0.012 - 0.016	0.013 - 0.02	0.015 - 0.022	0.02 - 0.025	0.022 - 0.04
0.0003 - 0.001	0.002 - 0.003	0.002 - 0.004	0.003 - 0.01	0.008 - 0.012	0.010 - 0.015	0.012 - 0.016	0.013 - 0.02	0.015 - 0.022	0.02 - 0.025
0.002 - 0.003	0.002 - 0.004	0.003 - 0.01	0.008 - 0.012	0.010 - 0.015	0.012 - 0.016	0.013 - 0.02	0.015 - 0.022	0.02 - 0.025	0.022 - 0.04
0.0003 - 0.001	0.002 - 0.003	0.002 - 0.004	0.003 - 0.01	0.008 - 0.012	0.010 - 0.015	0.012 - 0.016	0.013 - 0.02	0.015 - 0.022	0.02 - 0.025
0.002 - 0.003	0.002 - 0.004	0.003 - 0.01	0.008 - 0.012	0.010 - 0.015	0.012 - 0.016	0.013 - 0.02	0.015 - 0.022	0.02 - 0.025	0.022 - 0.04
0.002 - 0.003	0.002 - 0.004	0.003 - 0.01	0.008 - 0.012	0.010 - 0.015	0.012 - 0.016	0.013 - 0.02	0.015 - 0.022	0.02 - 0.025	0.022 - 0.04
		0.003 - 0.01	0.008 - 0.012	0.010 - 0.015	0.012 - 0.016	0.013 - 0.02	0.015 - 0.022	0.02 - 0.025	0.022 - 0.04
0.002 - 0.003	0.002 - 0.004	0.003 - 0.01	0.008 - 0.012	0.010 - 0.015	0.012 - 0.016	0.013 - 0.02	0.015 - 0.022	0.02 - 0.025	0.022 - 0.04
0.002 - 0.003	0.002 - 0.004	0.003 - 0.01	0.008 - 0.012	0.010 - 0.015	0.012 - 0.016	0.013 - 0.02	0.015 - 0.022	0.02 - 0.025	0.022 - 0.04
0.002 - 0.003	0.002 - 0.004	0.003 - 0.01	0.008 - 0.012	0.010 - 0.015	0.012 - 0.016	0.013 - 0.02	0.015 - 0.022	0.02 - 0.025	0.022 - 0.04
0.002 - 0.003	0.002 - 0.004	0.003 - 0.01	0.008 - 0.012	0.010 - 0.015	0.012 - 0.016	0.013 - 0.02	0.015 - 0.022	0.02 - 0.025	0.022 - 0.04
0.002 - 0.003	0.002 - 0.004	0.003 - 0.01	0.008 - 0.012	0.010 - 0.015	0.012 - 0.016	0.013 - 0.02	0.015 - 0.022	0.02 - 0.025	0.022 - 0.04
0.002 - 0.003	0.002 - 0.004	0.003 - 0.01	0.008 - 0.012	0.010 - 0.015	0.012 - 0.016	0.013 - 0.02	0.015 - 0.022	0.02 - 0.025	0.022 - 0.04
0.002 - 0.003	0.002 - 0.004	0.003 - 0.01	0.008 - 0.012	0.010 - 0.015	0.012 - 0.016	0.013 - 0.02	0.015 - 0.022	0.02 - 0.025	0.022 - 0.04
0.002 - 0.003	0.002 - 0.004	0.003 - 0.01	0.008 - 0.012	0.010 - 0.015	0.012 - 0.016	0.013 - 0.02	0.015 - 0.022	0.02 - 0.025	0.022 - 0.04
0.002 - 0.003	0.002 - 0.004	0.003 - 0.01	0.008 - 0.012	0.010 - 0.015	0.012 - 0.016	0.013 - 0.02	0.015 - 0.022	0.02 - 0.025	0.022 - 0.04
0.002 - 0.003	0.002 - 0.004	0.003 - 0.01	0.008 - 0.012	0.010 - 0.015	0.012 - 0.016	0.013 - 0.02	0.015 - 0.022	0.02 - 0.025	0.022 - 0.04



CONDITIONS DE COUPE

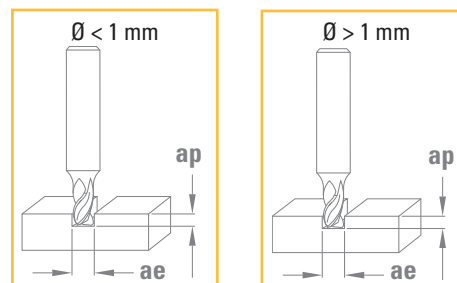

Matières à usiner

			CARBURE		TiAlN		ap [mm]	ae [mm]	ap [mm]	ae [mm]
			Vc [m/min]	Vc [m/min]	Vc [m/min]	Vc [m/min]				
P	Acier non allié / faiblement allié	< 600 N/mm ²	70	100	90	110	< 0.5 x ØD1	1 x ØD1	< 1.0 x ØD1	1 x ØD1
P	Acier non allié / faiblement allié	600 – 1500 N/mm ²	50	80	70	90	< 0.3 x ØD1	1 x ØD1	< 0.6 x ØD1	1 x ØD1
P	Acier de décolletage au plomb		70	100			< 0.5 x ØD1	1 x ØD1	< 1 x ØD1	1 x ØD1
P	Acier fortement allié	700 – 1500 N/mm ²			40	70	< 0.2 x ØD1	1 x ØD1	< 0.5 x ØD1	1 x ØD1
M	Acier inoxydable	400 – 700 N/mm ²	40	60	70	90	< 0.5 x ØD1	1 x ØD1	< 0.8 x ØD1	1 x ØD1
M	Acier inox. DUPLEX, acier austénitique inox. sans nickel	> 800 N/mm ²			40	70	< 0.2 x ØD1	1 x ØD1	< 0.5 x ØD1	1 x ØD1
K	Fonte grise / Fonte à graphite sphéroïdal perlitique	< 250 HB	70	100	90	110	< 0.5 x ØD1	1 x ØD1	< 1 x ØD1	1 x ØD1
K	Fonte alliée / Fonte à graphite sphéroïdal perlitique	> 250 HB	40	70	70	90	< 0.3 x ØD1	1 x ØD1	< 0.6 x ØD1	1 x ØD1
K	Fonte à graphite sphéroïdal ferritique / Fonte malléable		70	100	90	110	< 0.3 x ØD1	1 x ØD1	< 0.6 x ØD1	1 x ØD1
S	Super alliages / Acier inox. réfractaire	Inconel Nimonic Hastelloy			25	35			< 0.4 x ØD1	1 x ØD1
S	Titane, alliage de titane		30	45			< 0.30 x ØD1	1 x ØD1	< 0.5 x ØD1	1 x ØD1
N	Alliage de cuivre / bonne usinabilité (laiton – bronze)		140	160			< 0.5 x ØD1	1 x ØD1	< 1 x ØD1	1 x ØD1
N	Alliage de cuivre / usinabilité difficile / Bronze à l'aluminium	(CuAlFe) (Ampco)	120	140	170	190	< 0.3 x ØD1	1 x ØD1	< 0.7 x ØD1	1 x ØD1
N	Alliage d'aluminium	Si < 8%	180	260	230	340	< 0.6 x ØD1	1 x ØD1	< 1.2 x ØD1	1 x ØD1
N	Fonte d'aluminium	Si > 8%	140	160	210	230	< 0.4 x ØD1	1 x ØD1	< 0.9 x ØD1	1 x ØD1
N	Graphite		140	160	200	220	< 0.6 x ØD1	1 x ØD1	< 0.9 x ØD1	1 x ØD1
N	Plastique		240	260	300	340	< 0.6 x ØD1	1 x ØD1	< 1.2 x ØD1	1 x ØD1
N	Or, argent		140	160	200	220	< 0.6 x ØD1	1 x ØD1	< 0.9 x ØD1	1 x ØD1



$$n \text{ [tr/min]} = \frac{Vc \text{ [m/min]} \times 1000}{\pi \times D_1 \text{ [mm]}}$$

$$Vf \text{ [mm/min]} = n \text{ [tr/min]} \times fz \text{ [mm]} \times Z$$

Avance par dent **fz [mm]**

$\emptyset D_1$ 0.30 - 1.00	$\emptyset D_1$ 1.00 - 1.50	$\emptyset D_1$ 1.50 - 3.00	$\emptyset D_1$ 3.00 - 5.00	$\emptyset D_1$ 5.00 - 7.00	$\emptyset D_1$ 7.00 - 10.00	$\emptyset D_1$ 10.00 - 14.00	$\emptyset D_1$ 14.00 - 16.00	$\emptyset D_1$ 16.00 - 20.00
0.006 - 0.015	0.012 - 0.020	0.016 - 0.04	0.02 - 0.06	0.03 - 0.09	0.04 - 0.11	0.05 - 0.11	0.06 - 0.12	0.07 - 0.14
0.006 - 0.015	0.012 - 0.020	0.016 - 0.04	0.02 - 0.06	0.03 - 0.09	0.04 - 0.11	0.05 - 0.11	0.06 - 0.12	0.07 - 0.13
0.006 - 0.015	0.012 - 0.020	0.016 - 0.04	0.02 - 0.06	0.03 - 0.09	0.04 - 0.12	0.05 - 0.14	0.07 - 0.16	0.08 - 0.20
0.006 - 0.015	0.012 - 0.020	0.016 - 0.04	0.02 - 0.06	0.03 - 0.09	0.04 - 0.11	0.05 - 0.11	0.06 - 0.12	0.07 - 0.13
0.006 - 0.015	0.012 - 0.020	0.016 - 0.04	0.02 - 0.06	0.03 - 0.09	0.04 - 0.11	0.05 - 0.11	0.06 - 0.12	0.07 - 0.13
0.006 - 0.015	0.012 - 0.020	0.016 - 0.04	0.02 - 0.06	0.03 - 0.09	0.04 - 0.11	0.05 - 0.11	0.06 - 0.12	0.07 - 0.13
0.006 - 0.015	0.012 - 0.020	0.016 - 0.04	0.02 - 0.06	0.03 - 0.09	0.04 - 0.11	0.05 - 0.11	0.06 - 0.12	0.07 - 0.13
0.006 - 0.015	0.012 - 0.020	0.016 - 0.04	0.02 - 0.06	0.03 - 0.09	0.04 - 0.11	0.05 - 0.11	0.06 - 0.12	0.07 - 0.13
0.006 - 0.015	0.012 - 0.020	0.016 - 0.04	0.02 - 0.06	0.03 - 0.09	0.04 - 0.11	0.05 - 0.11	0.06 - 0.12	0.07 - 0.13
0.006 - 0.015	0.012 - 0.020	0.016 - 0.04	0.02 - 0.06	0.03 - 0.09	0.04 - 0.11	0.05 - 0.11	0.06 - 0.12	0.07 - 0.13
0.006 - 0.015	0.012 - 0.020	0.016 - 0.04	0.02 - 0.06	0.03 - 0.09	0.04 - 0.11	0.05 - 0.11	0.06 - 0.12	0.07 - 0.13
0.006 - 0.015	0.012 - 0.020	0.016 - 0.04	0.02 - 0.06	0.03 - 0.09	0.04 - 0.11	0.05 - 0.14	0.07 - 0.16	0.08 - 0.20
0.006 - 0.015	0.012 - 0.020	0.016 - 0.04	0.02 - 0.06	0.03 - 0.09	0.04 - 0.11	0.05 - 0.11	0.06 - 0.12	0.07 - 0.13
0.006 - 0.015	0.012 - 0.020	0.016 - 0.04	0.02 - 0.06	0.03 - 0.09	0.04 - 0.12	0.05 - 0.14	0.07 - 0.16	0.08 - 0.20
0.006 - 0.015	0.012 - 0.020	0.016 - 0.04	0.02 - 0.06	0.03 - 0.09	0.04 - 0.12	0.05 - 0.14	0.07 - 0.16	0.08 - 0.20
0.006 - 0.015	0.005 - 0.020	0.016 - 0.04	0.02 - 0.06	0.03 - 0.09	0.04 - 0.12	0.05 - 0.14	0.07 - 0.16	0.08 - 0.20
0.006 - 0.015	0.012 - 0.020	0.016 - 0.04	0.02 - 0.06	0.03 - 0.09	0.04 - 0.12	0.05 - 0.21	0.10 - 0.24	0.11 - 0.30
0.006 - 0.015	0.005 - 0.020	0.016 - 0.04	0.02 - 0.06	0.03 - 0.09	0.04 - 0.12	0.05 - 0.14	0.07 - 0.16	0.08 - 0.20



CONDITIONS DE COUPE - RAINURAGE

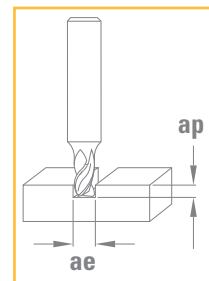

Matières à usiner			CUTINOX		ap
			Vc [m/min]		[mm]
P	Acier non allié / faiblement allié	< 600 N/mm ²	100	170	< 1 x ØD1
P	Acier non allié / faiblement allié	600 – 1500 N/mm ²	90	150	< 1 x ØD1
P	Acier de décolletage au plomb		120	180	< 1 x ØD1
P	Acier fortement allié	700 – 1500 N/mm ²	50	90	< 0.7 x ØD1
M	Acier inoxydable	400 – 700 N/mm ²	60	95	< 1 x ØD1
M	Acier inox. DUPLEX, acier austénitique inox. sans nickel	> 800 N/mm ²	50	90	< 0.7 x ØD1
K	Fonte grise / Fonte à graphite sphéroïdal perlitique	< 250 HB	140	180	< 1 x ØD1
K	Fonte alliée / Fonte à graphite sphéroïdal perlitique	> 250 HB	110	150	< 1 x ØD1
K	Fonte à graphite sphéroïdal ferritique / Fonte malléable		100	140	< 1 x ØD1
S	Super alliages / Acier inox. réfractaire	Inconel Nimonic Hastelloy	40	70	< 1 x ØD1
S	Titane, alliage de titane		20	40	< 0.3 x ØD1

Conditions de coupe basées sur l'huile entière.

Pour les aciers fortement alliés (>12% Chrome), les aciers inoxydables, les alliages de titane, réduire la vitesse de coupe de 20% si le lubrifiant est de l'huile en émulsion.

$$n \text{ [tr/min]} = \frac{Vc \text{ [m/min]} \times 1000}{\pi \times D_1 \text{ [mm]}}$$

$$Vf \text{ [mm/min]} = n \text{ [tr/min]} \times fz \text{ [mm]} \times Z$$

Avance par dent **fz [mm]**

$\emptyset D_1$ 3.00 - 4.00	$\emptyset D_1$ 4.00 - 6.00	$\emptyset D_1$ 6.00 - 8.00	$\emptyset D_1$ 8.00 - 10.00	$\emptyset D_1$ 10.00 - 12.00	$\emptyset D_1$ 12.00 - 16.00	$\emptyset D_1$ 16.00 - 20.00	
0.010 - 0.017	0.013 - 0.035	0.020 - 0.055	0.023 - 0.070	0.029 - 0.080	0.035 - 0.090	0.046 - 0.100	
0.009 - 0.015	0.012 - 0.030	0.017 - 0.045	0.020 - 0.060	0.025 - 0.070	0.030 - 0.080	0.040 - 0.090	
0.013 - 0.023	0.017 - 0.045	0.026 - 0.068	0.030 - 0.090	0.038 - 0.105	0.045 - 0.120	0.040 - 0.135	
0.007 - 0.013	0.010 - 0.025	0.015 - 0.040	0.017 - 0.050	0.021 - 0.060	0.026 - 0.070	0.034 - 0.075	
0.009 - 0.015	0.012 - 0.030	0.017 - 0.045	0.020 - 0.060	0.025 - 0.070	0.030 - 0.080	0.040 - 0.090	
0.007 - 0.013	0.010 - 0.025	0.015 - 0.040	0.017 - 0.050	0.021 - 0.060	0.026 - 0.070	0.034 - 0.075	
0.013 - 0.023	0.017 - 0.045	0.026 - 0.068	0.030 - 0.090	0.038 - 0.105	0.045 - 0.120	0.040 - 0.135	
0.012 - 0.020	0.016 - 0.040	0.023 - 0.060	0.027 - 0.080	0.034 - 0.095	0.041 - 0.110	0.036 - 0.120	
0.012 - 0.020	0.016 - 0.040	0.023 - 0.060	0.027 - 0.080	0.034 - 0.095	0.041 - 0.110	0.036 - 0.120	
0.010 - 0.017	0.013 - 0.035	0.020 - 0.055	0.023 - 0.070	0.029 - 0.080	0.035 - 0.090	0.046 - 0.100	
0.004 - 0.010	0.005 - 0.013	0.007 - 0.020	0.010 - 0.023	0.013 - 0.026	0.013 - 0.033	0.020 - 0.039	



CONDITIONS DE COUPE - CONTOURNAGE

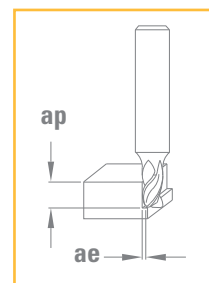

Matières à usiner			CUTINOX		ap [mm]	ae [mm]
			Vc [m/min]			
P	Acier non allié / faiblement allié	< 600 N/mm ²	160	200	< 1 x ØD1	< 0.6 x ØD1
P	Acier non allié / faiblement allié	600 – 1500 N/mm ²	130	170	< 1 x ØD1	< 0.6 x ØD1
P	Acier de décolletage au plomb		160	200	< 1 x ØD1	< 0.6 x ØD1
P	Acier fortement allié	700 – 1500 N/mm ²	70	100	< 1 x ØD1	< 0.5 x ØD1
M	Acier inoxydable	400 – 700 N/mm ²	80	110	< 1 x ØD1	< 0.5 x ØD1
M	Acier inox. DUPLEX, acier austénitique inox. sans nickel	> 800 N/mm ²	70	100	< 1 x ØD1	< 0.5 x ØD1
K	Fonte grise / Fonte à graphite sphéroïdal perlitique	< 250 HB	160	200	< 1 x ØD1	< 0.6 x ØD1
K	Fonte allié / Fonte à graphite sphéroïdal perlitique	> 250 HB	130	170	< 1 x ØD1	< 0.6 x ØD1
K	Fonte à graphite sphéroïdal ferritique / Fonte malléable		110	150	< 1 x ØD1	< 0.6 x ØD1
S	Super alliages / Acier inox. réfractaire	Inconel Nimonic Hastelloy	40	70	< 1 x ØD1	< 0.6 x ØD1
S	Titane, alliage de titane		20	50	< 1 x ØD1	< 0.3 x ØD1

Conditions de coupe basées sur l'huile entière.

Pour les aciers fortement alliés (>12% Chrome), les aciers inoxydables, les alliages de titane, réduire la vitesse de coupe de 20% si le lubrifiant est de l'huile en émulsion.

Si $ae < 0.1 \times D$, augmenter VC et fz de 25%.

$$n \text{ [tr/min]} = \frac{Vc \text{ [m/min]} \times 1000}{\pi \times D_1 \text{ [mm]}}$$

$$Vf \text{ [mm/min]} = n \text{ [tr/min]} \times fz \text{ [mm]} \times Z$$

Avance par dent **fz [mm]**

$\emptyset D_1$ 3.00 - 4.00	$\emptyset D_1$ 4.00 - 6.00	$\emptyset D_1$ 6.00 - 8.00	$\emptyset D_1$ 8.00 - 10.00	$\emptyset D_1$ 10.00 - 12.00	$\emptyset D_1$ 12.00 - 16.00	$\emptyset D_1$ 16.00 - 20.00
0.019 - 0.045	0.029 - 0.070	0.040 - 0.100	0.052 - 0.115	0.057 - 0.130	0.063 - 0.155	0.086 - 0.185
0.017 - 0.040	0.023 - 0.065	0.035 - 0.085	0.046 - 0.105	0.052 - 0.115	0.058 - 0.135	0.075 - 0.165
0.029 - 0.065	0.035 - 0.100	0.052 - 0.130	0.069 - 0.155	0.081 - 0.175	0.086 - 0.210	0.115 - 0.250
0.014 - 0.035	0.017 - 0.050	0.029 - 0.070	0.040 - 0.085	0.046 - 0.090	0.052 - 0.110	0.063 - 0.130
0.017 - 0.040	0.023 - 0.065	0.035 - 0.085	0.046 - 0.105	0.052 - 0.115	0.058 - 0.135	0.075 - 0.165
0.014 - 0.035	0.017 - 0.050	0.029 - 0.070	0.040 - 0.085	0.046 - 0.090	0.052 - 0.110	0.063 - 0.130
0.029 - 0.065	0.035 - 0.100	0.052 - 0.130	0.069 - 0.155	0.081 - 0.175	0.086 - 0.210	0.115 - 0.250
0.024 - 0.055	0.029 - 0.085	0.044 - 0.111	0.059 - 0.132	0.068 - 0.149	0.073 - 0.179	0.098 - 0.213
0.024 - 0.055	0.029 - 0.085	0.044 - 0.111	0.059 - 0.132	0.068 - 0.149	0.073 - 0.179	0.098 - 0.213
0.019 - 0.045	0.029 - 0.070	0.040 - 0.100	0.052 - 0.115	0.057 - 0.130	0.063 - 0.155	0.086 - 0.185
0.007 - 0.017	0.009 - 0.025	0.012 - 0.035	0.017 - 0.040	0.023 - 0.050	0.026 - 0.060	0.032 - 0.070



CONDITIONS DE COUPE - RAINURAGE

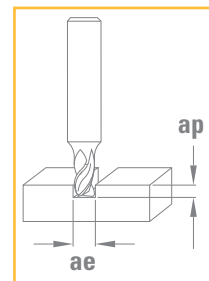

Matières à usiner			CUTINOX		ap
			Vc [m/min]		[mm]
P	Acier non allié / faiblement allié	< 600 N/mm ²	100	170	< 1 x ØD1
P	Acier non allié / faiblement allié	600 – 1500 N/mm ²	90	150	< 1 x ØD1
P	Acier de décolletage au plomb		120	180	< 1 x ØD1
P	Acier fortement allié	700 – 1500 N/mm ²	50	90	< 0.7 x ØD1
M	Acier inoxydable	400 – 700 N/mm ²	60	95	< 1 x ØD1
M	Acier inox. DUPLEX, acier austénitique inox. sans nickel	> 800 N/mm ²	50	90	< 0.7 x ØD1
K	Fonte grise / Fonte à graphite sphéroïdal perlitique	< 250 HB	140	180	< 1 x ØD1
K	Fonte alliée / Fonte à graphite sphéroïdal perlitique	> 250 HB	110	150	< 1 x ØD1
K	Fonte à graphite sphéroïdal ferritique / Fonte malléable		100	140	< 1 x ØD1
S	Super alliages / Acier inox. réfractaire	Inconel Nimonic Hastelloy	30	55	< 1 x ØD1
S	Titane, alliage de titane		20	50	< 0.3 x ØD1

Conditions de coupe basées sur l'huile entière.

Pour les aciers fortement alliés (>12% Chrome), les aciers inoxydables, les alliages de titane, réduire la vitesse de coupe de 20% si le lubrifiant est de l'huile en émulsion.



$$n \text{ [tr/min]} = \frac{Vc \text{ [m/min]} \times 1000}{\pi \times D_1 \text{ [mm]}}$$

$$Vf \text{ [mm/min]} = n \text{ [tr/min]} \times fz \text{ [mm]} \times Z$$

Avance par dent **fz [mm]**

$\emptyset D_1$ 1.50 - 3.00	$\emptyset D_1$ 3.00 - 4.00	$\emptyset D_1$ 4.00 - 6.00	$\emptyset D_1$ 6.00 - 8.00	$\emptyset D_1$ 8.00 - 10.00	$\emptyset D_1$ 10.00 - 12.00	$\emptyset D_1$ 12.00 - 16.00	$\emptyset D_1$ 16.00 - 20.00
0.005 - 0.010	0.008 - 0.020	0.011 - 0.030	0.017 - 0.040	0.022 - 0.050	0.025 - 0.055	0.030 - 0.065	0.040 - 0.085
0.005 - 0.010	0.008 - 0.018	0.010 - 0.025	0.015 - 0.035	0.020 - 0.045	0.023 - 0.050	0.025 - 0.060	0.035 - 0.075
0.010 - 0.020	0.013 - 0.030	0.015 - 0.045	0.023 - 0.050	0.025 - 0.070	0.030 - 0.075	0.032 - 0.080	0.035 - 0.110
0.004 - 0.010	0.006 - 0.015	0.008 - 0.020	0.013 - 0.030	0.018 - 0.035	0.020 - 0.040	0.025 - 0.050	0.030 - 0.060
0.005 - 0.010	0.008 - 0.018	0.010 - 0.025	0.015 - 0.035	0.020 - 0.045	0.023 - 0.050	0.025 - 0.060	0.035 - 0.075
0.004 - 0.010	0.006 - 0.015	0.008 - 0.020	0.013 - 0.030	0.018 - 0.035	0.020 - 0.040	0.025 - 0.050	0.030 - 0.060
0.010 - 0.020	0.013 - 0.030	0.015 - 0.045	0.023 - 0.050	0.025 - 0.070	0.030 - 0.075	0.032 - 0.080	0.035 - 0.110
0.008 - 0.015	0.011 - 0.025	0.013 - 0.040	0.019 - 0.045	0.021 - 0.060	0.026 - 0.065	0.027 - 0.070	0.030 - 0.095
0.008 - 0.015	0.011 - 0.025	0.013 - 0.040	0.019 - 0.045	0.021 - 0.060	0.026 - 0.065	0.027 - 0.070	0.030 - 0.095
0.005 - 0.010	0.008 - 0.020	0.011 - 0.030	0.017 - 0.040	0.022 - 0.050	0.025 - 0.055	0.030 - 0.065	0.040 - 0.085
0.001 - 0.005	0.003 - 0.008	0.004 - 0.010	0.005 - 0.015	0.008 - 0.018	0.010 - 0.020	0.010 - 0.025	0.015 - 0.030



CONDITIONS DE COUPE - CONTOURNAGE

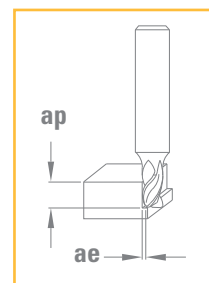

Matières à usiner			CUTINOX		ap [mm]	ae [mm]
			Vc [m/min]			
P	Acier non allié / faiblement allié	< 600 N/mm ²	160	200	< 2 x ØD1	< 0.4 x ØD1
P	Acier non allié / faiblement allié	600 – 1500 N/mm ²	130	170	< 2 x ØD1	< 0.3 x ØD1
P	Acier de décolletage au plomb		160	200	< 2 x ØD1	< 0.4 x ØD1
P	Acier fortement allié	700 – 1500 N/mm ²	70	100	< 2 x ØD1	< 0.3 x ØD1
M	Acier inoxydable	400 – 700 N/mm ²	80	110	< 2 x ØD1	< 0.3 x ØD1
M	Acier inox. DUPLEX, acier austénitique inox. sans nickel	> 800 N/mm ²	70	100	< 2 x ØD1	< 0.3 x ØD1
K	Fonte grise / Fonte à graphite sphéroïdal perlitique	< 250 HB	160	200	< 2 x ØD1	< 0.4 x ØD1
K	Fonte alliée / Fonte à graphite sphéroïdal perlitique	> 250 HB	130	170	< 2 x ØD1	< 0.4 x ØD1
K	Fonte à graphite sphéroïdal ferritique / Fonte malléable		110	150	< 2 x ØD1	< 0.3 x ØD1
S	Super alliages / Acier inox. réfractaire	Inconel Nimonic Hastelloy	20	50	< 2 x ØD1	< 0.2 x ØD1
S	Titane, alliage de titane		40	70	< 2 x ØD1	< 0.3 x ØD1

Conditions de coupe basées sur l'huile entière.

Pour les aciers fortement alliés (>12% Chrome), les aciers inoxydables, les alliages de titane, réduire la vitesse de coupe de 20% si le lubrifiant est de l'huile en émulsion.

Si ae < 0.1 x D, augmenter VC et fz de 25%.



$$n \text{ [tr/min]} = \frac{Vc \text{ [m/min]} \times 1000}{\pi \times D_1 \text{ [mm]}}$$

$$Vf \text{ [mm/min]} = n \text{ [tr/min]} \times fz \text{ [mm]} \times Z$$

Avance par dent **fz [mm]**

$\emptyset D_1$ 1.50 - 3.00	$\emptyset D_1$ 3.00 - 4.00	$\emptyset D_1$ 4.00 - 6.00	$\emptyset D_1$ 6.00 - 8.00	$\emptyset D_1$ 8.00 - 10.00	$\emptyset D_1$ 10.00 - 12.00	$\emptyset D_1$ 12.00 - 16.00	$\emptyset D_1$ 16.00 - 20.00
0.015 - 0.030	0.019 - 0.040	0.025 - 0.060	0.035 - 0.085	0.045 - 0.100	0.050 - 0.110	0.055 - 0.135	0.075 - 0.160
0.011 - 0.025	0.015 - 0.035	0.020 - 0.055	0.030 - 0.075	0.040 - 0.090	0.045 - 0.100	0.050 - 0.120	0.068 - 0.144
0.021 - 0.045	0.025 - 0.055	0.030 - 0.085	0.045 - 0.115	0.060 - 0.135	0.070 - 0.150	0.075 - 0.180	0.100 - 0.220
0.008 - 0.020	0.012 - 0.030	0.015 - 0.045	0.025 - 0.060	0.035 - 0.075	0.040 - 0.080	0.045 - 0.095	0.055 - 0.115
0.011 - 0.025	0.015 - 0.035	0.020 - 0.055	0.030 - 0.075	0.040 - 0.090	0.045 - 0.100	0.050 - 0.120	0.065 - 0.145
0.008 - 0.020	0.012 - 0.030	0.015 - 0.045	0.025 - 0.060	0.035 - 0.075	0.040 - 0.080	0.045 - 0.095	0.055 - 0.115
0.021 - 0.045	0.025 - 0.055	0.030 - 0.085	0.045 - 0.115	0.060 - 0.135	0.070 - 0.150	0.075 - 0.180	0.100 - 0.220
0.017 - 0.037	0.021 - 0.047	0.026 - 0.072	0.038 - 0.098	0.051 - 0.115	0.060 - 0.128	0.064 - 0.153	0.085 - 0.187
0.017 - 0.037	0.021 - 0.047	0.026 - 0.072	0.038 - 0.098	0.051 - 0.115	0.060 - 0.128	0.064 - 0.153	0.085 - 0.187
0.003 - 0.007	0.006 - 0.015	0.008 - 0.020	0.010 - 0.030	0.015 - 0.035	0.020 - 0.040	0.023 - 0.050	0.028 - 0.060
0.013 - 0.030	0.017 - 0.040	0.025 - 0.060	0.035 - 0.085	0.045 - 0.100	0.050 - 0.110	0.055 - 0.135	0.075 - 0.160



CONDITIONS DE COUPE

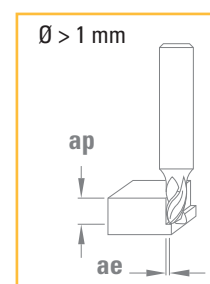
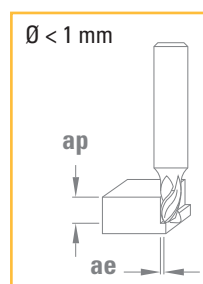

Matières à usiner			CARBURE		TiAIN		$\varnothing < 1 \text{ mm}$		$\varnothing > 1 \text{ mm}$	
			Vc [m/min]	Vc [m/min]	Vc [m/min]	Vc [m/min]	ap [mm]	ae [mm]	ap [mm]	ae [mm]
P	Acier non allié / faiblement allié	< 600 N/mm ²	70	100	90	110	< 1 x ØD1	< 0.2 x ØD1	< 1 x ØD1	< 0.3 x ØD1
P	Acier non allié / faiblement allié	600 – 1500 N/mm ²			70	90	< 1 x ØD1	< 0.10 x ØD1	< 1 x ØD1	< 0.2 x ØD1
P	Acier de décolletage au plomb		70	100			< 1.5 x ØD1	< 0.2 x ØD1	< 1.5 x ØD1	< 0.3 x ØD1
P	Acier fortement allié	700 – 1500 N/mm ²			40	55	< 1 x ØD1	< 0.10 x ØD1	< 1 x ØD1	< 0.2 x ØD1
M	Acier inoxydable	400 – 700 N/mm ²			70	90	< 1 x ØD1	< 0.1 x ØD1	< 1 x ØD1	< 0.3 x ØD1
M	Acier inox. DUPLEX, acier austénitique inox. sans nickel	> 800 N/mm ²			40	55	< 1 x ØD1	< 0.10 x ØD1	< 1 x ØD1	< 0.2 x ØD1
K	Fonte grise / Fonte à graphite sphéroïdal perlitique	< 250 HB	70	100	90	110	< 1 x ØD1	< 0.1 x ØD1	< 1 x ØD1	< 0.3 x ØD1
K	Fonte allié / Fonte à graphite sphéroïdal perlitique	> 250 HB	40	70	70	90	< 1 x ØD1	< 0.1 x ØD1	< 1 x ØD1	< 0.3 x ØD1
K	Fonte à graphite sphéroïdal ferritique / Fonte malléable		70	100	90	110	< 1 x ØD1	< 0.1 x ØD1	< 1 x ØD1	< 0.3 x ØD1
S	Titane, alliage de titane		30	45			< 1 x ØD1	< 0.1 x ØD1	< 1 x ØD1	< 0.3 x ØD1
N	Alliage de cuivre / bonne usinabilité (laiton – bronze)		140	160			< 1.5 x ØD1	< 0.2 x ØD1	< 1.5 x ØD1	< 0.3 x ØD1
N	Alliage de cuivre / usinabilité difficile / Bronze à l'aluminium (CuAlFe) (Ampco)		120	140	170	190	< 1 x ØD1	< 0.1 x ØD1	< 1 x ØD1	< 0.2 x ØD1
N	Alliage d'aluminium	Si < 8%	180	220	230	270	< 1.5 x ØD1	< 0.2 x ØD1	< 1.5 x ØD1	< 0.3 x ØD1
N	Fonte d'aluminium	Si > 8%	140	160	210	230	< 1.5 x ØD1	< 0.2 x ØD1	< 1.5 x ØD1	< 0.3 x ØD1
N	Plastique		240	260	300	340	< 1.5 x ØD1	< 0.2 x ØD1	< 1.5 x ØD1	< 0.3 x ØD1
N	Or, argent		140	160	200	220	< 1.5 x ØD1	< 0.2 x ØD1	< 1.5 x ØD1	< 0.3 x ØD1

DIXI 7244 DIAMANT

CONDITIONS DE COUPE

Matières à usiner		DIAMANT		ap [mm]	ae [mm]
		Vc [m/min]	Vc [m/min]		
N	Graphite	200	300	< 1.5 x ØD1	< 0.2 x ØD1



$$n \text{ [tr/min]} = \frac{Vc \text{ [m/min]} \times 1000}{\pi \times D_1 \text{ [mm]}}$$

$$Vf \text{ [mm/min]} = n \text{ [tr/min]} \times fz \text{ [mm]} \times Z$$

Avance par dent **fz [mm]**

Ø D ₁ 0.40 - 1.00	Ø D ₁ 1.00 - 1.50	Ø D ₁ 1.50 - 3.00	Ø D ₁ 3.00 - 5.00	Ø D ₁ 5.00 - 7.00	Ø D ₁ 7.00 - 10.00	Ø D ₁ 10.00 - 14.00	Ø D ₁ 14.00 - 16.00	Ø D ₁ 16.00 - 20.00	
0.006 - 0.015	0.012 - 0.020	0.016 - 0.04	0.02 - 0.06	0.03 - 0.09	0.04 - 0.12	0.05 - 0.10	0.06 - 0.11	0.07 - 0.14	
0.006 - 0.015	0.012 - 0.020	0.016 - 0.04	0.02 - 0.06	0.03 - 0.09	0.04 - 0.12	0.05 - 0.07	0.06 - 0.08	0.07 - 0.10	
0.006 - 0.015	0.012 - 0.020	0.016 - 0.04	0.02 - 0.06	0.03 - 0.09	0.04 - 0.12	0.05 - 0.14	0.07 - 0.16	0.08 - 0.20	
0.006 - 0.015	0.012 - 0.020	0.016 - 0.04	0.02 - 0.06	0.03 - 0.09	0.04 - 0.12	0.05 - 0.13	0.06 - 0.14	0.07 - 0.15	
0.006 - 0.015	0.012 - 0.020	0.016 - 0.04	0.02 - 0.06	0.03 - 0.09	0.04 - 0.12	0.05 - 0.13	0.06 - 0.14	0.07 - 0.15	
0.006 - 0.015	0.012 - 0.020	0.016 - 0.04	0.02 - 0.06	0.03 - 0.09	0.04 - 0.12	0.05 - 0.13	0.06 - 0.14	0.07 - 0.15	
0.006 - 0.015	0.012 - 0.020	0.016 - 0.04	0.02 - 0.06	0.03 - 0.09	0.04 - 0.12	0.05 - 0.13	0.06 - 0.14	0.07 - 0.15	
0.006 - 0.015	0.012 - 0.020	0.016 - 0.04	0.02 - 0.06	0.03 - 0.09	0.04 - 0.12	0.05 - 0.13	0.06 - 0.14	0.07 - 0.15	
0.006 - 0.015	0.012 - 0.020	0.016 - 0.04	0.02 - 0.06	0.03 - 0.09	0.04 - 0.12	0.05 - 0.14	0.07 - 0.16	0.08 - 0.20	
0.006 - 0.015	0.012 - 0.020	0.016 - 0.04	0.02 - 0.06	0.03 - 0.09	0.04 - 0.12	0.05 - 0.07	0.06 - 0.08	0.07 - 0.10	
0.006 - 0.015	0.012 - 0.020	0.016 - 0.04	0.02 - 0.06	0.03 - 0.09	0.04 - 0.12	0.05 - 0.14	0.07 - 0.16	0.08 - 0.20	
0.006 - 0.015	0.012 - 0.020	0.016 - 0.04	0.02 - 0.06	0.03 - 0.09	0.04 - 0.12	0.05 - 0.14	0.07 - 0.16	0.08 - 0.20	
0.006 - 0.015	0.012 - 0.020	0.016 - 0.04	0.02 - 0.06	0.03 - 0.09	0.04 - 0.12	0.05 - 0.14	0.07 - 0.16	0.08 - 0.20	
0.006 - 0.015	0.012 - 0.020	0.016 - 0.04	0.02 - 0.06	0.03 - 0.09	0.04 - 0.12	0.05 - 0.14	0.07 - 0.16	0.08 - 0.20	
0.006 - 0.015	0.012 - 0.020	0.016 - 0.04	0.02 - 0.06	0.03 - 0.09	0.04 - 0.12	0.05 - 0.14	0.07 - 0.16	0.08 - 0.20	
0.006 - 0.015	0.005 - 0.020	0.016 - 0.04	0.02 - 0.06	0.03 - 0.09	0.04 - 0.12	0.05 - 0.14	0.07 - 0.16	0.08 - 0.20	

Avance par dent

Ø D ₁ 0.40 - 1.00	Ø D ₁ 1.00 - 1.50	Ø D ₁ 1.50 - 3.00	Ø D ₁ 3.00 - 5.00	Ø D ₁ 5.00 - 7.00	Ø D ₁ 7.00 - 10.00	Ø D ₁ 10.00 - 14.00	Ø D ₁ 14.00 - 16.00	Ø D ₁ 16.00 - 20.00	
0.006 - 0.015	0.012 - 0.020	0.016 - 0.04	0.02 - 0.06	0.03 - 0.09	0.04 - 0.12	0.05 - 0.14	0.07 - 0.16	0.08 - 0.20	



CONDITIONS DE COUPE

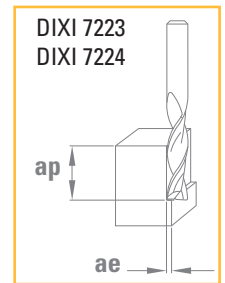
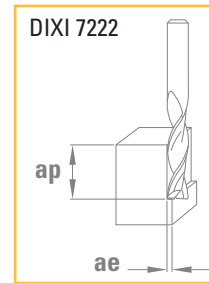

Matières à usiner

			CARBURE		TiAlN		ap [mm]		ae [mm]	
			Vc [m/min]	Vc [m/min]	Vc [m/min]	Vc [m/min]	3 x ØD1	< 0.30 x ØD1	3 x ØD1	< 0.20 x ØD1
P	Acier non allié / faiblement allié	< 600 N/mm ²	45	50	50	60	3 x ØD1	< 0.30 x ØD1	3 x ØD1	< 0.20 x ØD1
P	Acier non allié / faiblement allié	600 – 1500 N/mm ²			35	45	3 x ØD1	< 0.20 x ØD1	3 x ØD1	< 0.10 x ØD1
P	Acier de décolletage au plomb		45	50			3 x ØD1	< 0.30 x ØD1	3 x ØD1	< 0.20 x ØD1
P	Acier fortement allié	700 – 1500 N/mm ²			30	45	3 x ØD1	< 0.15 x ØD1	3 x ØD1	< 0.07 x ØD1
M	Acier inoxydable	400 – 700 N/mm ²			35	45	3 x ØD1	< 0.20 x ØD1	3 x ØD1	< 0.10 x ØD1
M	Acier inox. DUPLEX, acier austénitique inox. sans nickel	> 800 N/mm ²			30	45	3 x ØD1	< 0.30 x ØD1	3 x ØD1	< 0.07 x ØD1
K	Fonte grise / Fonte à graphite sphéroïdal perlitique	< 250 HB	25	35	35	45	3 x ØD1	< 0.15 x ØD1	3 x ØD1	< 0.20 x ØD1
K	Fonte allié / Fonte à graphite sphéroïdal perlitique	> 250 HB	25	35	35	45	3 x ØD1	< 0.30 x ØD1	3 x ØD1	< 0.07 x ØD1
K	Fonte à graphite sphéroïdal ferritique / Fonte malléable		25	35	35	45	3 x ØD1	< 0.10 x ØD1	3 x ØD1	< 0.20 x ØD1
S	Titane, alliage de titane		15	25			3 x ØD1	< 0.15 x ØD1	3 x ØD1	< 0.03 x ØD1
N	Alliage de cuivre / bonne usinabilité (laiton – bronze)		80	100			3 x ØD1	< 0.30 x ØD1	3 x ØD1	< 0.20 x ØD1
N	Alliage de cuivre / usinabilité difficile / Bronze à l'aluminium (CuAlFe)		60	80	80	100	3 x ØD1	< 0.30 x ØD1	3 x ØD1	< 0.20 x ØD1
N	Alliage d'aluminium	Si < 8%	80	110	100	130	3 x ØD1	< 0.40 x ØD1	3 x ØD1	< 0.30 x ØD1
N	Fonte d'aluminium	Si > 8%	80	100	100	120	3 x ØD1	< 0.40 x ØD1	3 x ØD1	< 0.30 x ØD1
N	Plastique		90	110	110	130	3 x ØD1	< 0.40 x ØD1	3 x ØD1	< 0.30 x ØD1
N	Or, argent		80	100	100	120	3 x ØD1	< 0.40 x ØD1	3 x ØD1	< 0.30 x ØD1

DIXI 7222 - 7223 - 7224 DIAMANT

CONDITIONS DE COUPE

Matières à usiner

		DIAMANT		ap [mm]		ae [mm]	
		Vc [m/min]	Vc [m/min]	3 x ØD1	< 0.30 x ØD1	3 x ØD1	< 0.30 x ØD1
N	Graphite	200	300	3 x ØD1	< 0.30 x ØD1	3 x ØD1	< 0.30 x ØD1



$$n \text{ [tr/min]} = \frac{Vc \text{ [m/min]} \times 1000}{\pi \times D_1 \text{ [mm]}}$$

$$Vf \text{ [mm/min]} = n \text{ [tr/min]} \times fz \text{ [mm]} \times Z$$

Avance par dent **fz [mm]**

Ø D ₁ 3.00 - 4.00	Ø D ₁ 4.00 - 5.00	Ø D ₁ 5.00 - 6.00	Ø D ₁ 6.00 - 7.00	Ø D ₁ 7.00 - 8.00	Ø D ₁ 8.00 - 10.00	Ø D ₁ 10.00 - 12.00	Ø D ₁ 12.00 - 14.00	Ø D ₁ 14.00 - 16.00	Ø D ₁ 16.00 - 20.00
0.006 - 0.01	0.008 - 0.02	0.010 - 0.02	0.012 - 0.02	0.014 - 0.03	0.018 - 0.04	0.02 - 0.04	0.02 - 0.05	0.03 - 0.06	0.03 - 0.07
0.005 - 0.01	0.006 - 0.01	0.008 - 0.02	0.009 - 0.02	0.011 - 0.02	0.014 - 0.03	0.02 - 0.03	0.02 - 0.04	0.02 - 0.04	0.02 - 0.05
0.008 - 0.02	0.010 - 0.03	0.013 - 0.03	0.015 - 0.04	0.018 - 0.04	0.023 - 0.05	0.03 - 0.06	0.03 - 0.07	0.04 - 0.08	0.04 - 0.10
0.005 - 0.01	0.006 - 0.01	0.008 - 0.02	0.009 - 0.02	0.011 - 0.02	0.014 - 0.03	0.02 - 0.03	0.02 - 0.04	0.02 - 0.04	0.02 - 0.05
0.005 - 0.01	0.006 - 0.01	0.008 - 0.02	0.009 - 0.02	0.011 - 0.02	0.014 - 0.03	0.02 - 0.03	0.02 - 0.04	0.02 - 0.04	0.02 - 0.05
0.005 - 0.01	0.006 - 0.01	0.008 - 0.02	0.009 - 0.02	0.011 - 0.02	0.014 - 0.03	0.02 - 0.03	0.02 - 0.04	0.02 - 0.04	0.02 - 0.05
0.006 - 0.01	0.008 - 0.02	0.010 - 0.02	0.012 - 0.02	0.014 - 0.03	0.018 - 0.04	0.02 - 0.04	0.02 - 0.05	0.03 - 0.06	0.03 - 0.07
0.005 - 0.01	0.006 - 0.01	0.008 - 0.02	0.009 - 0.02	0.011 - 0.02	0.014 - 0.03	0.02 - 0.03	0.02 - 0.04	0.02 - 0.04	0.02 - 0.05
0.006 - 0.01	0.008 - 0.02	0.010 - 0.02	0.012 - 0.02	0.014 - 0.03	0.018 - 0.04	0.02 - 0.04	0.02 - 0.05	0.03 - 0.06	0.03 - 0.07
0.005 - 0.01	0.006 - 0.01	0.008 - 0.02	0.009 - 0.02	0.011 - 0.02	0.014 - 0.03	0.02 - 0.03	0.02 - 0.04	0.02 - 0.04	0.02 - 0.05
0.008 - 0.02	0.010 - 0.03	0.013 - 0.03	0.015 - 0.04	0.018 - 0.04	0.023 - 0.05	0.03 - 0.06	0.03 - 0.07	0.04 - 0.08	0.04 - 0.10
0.005 - 0.01	0.006 - 0.01	0.008 - 0.02	0.009 - 0.02	0.011 - 0.02	0.014 - 0.03	0.02 - 0.03	0.02 - 0.04	0.02 - 0.04	0.02 - 0.05
0.008 - 0.02	0.010 - 0.03	0.013 - 0.03	0.015 - 0.04	0.018 - 0.04	0.023 - 0.05	0.03 - 0.06	0.03 - 0.07	0.04 - 0.08	0.04 - 0.10
0.008 - 0.02	0.010 - 0.03	0.013 - 0.03	0.015 - 0.04	0.018 - 0.04	0.023 - 0.05	0.03 - 0.06	0.03 - 0.07	0.04 - 0.08	0.04 - 0.10
0.011 - 0.03	0.014 - 0.04	0.018 - 0.05	0.021 - 0.05	0.025 - 0.06	0.032 - 0.08	0.04 - 0.09	0.04 - 0.11	0.05 - 0.12	0.06 - 0.15
0.008 - 0.02	0.010 - 0.03	0.013 - 0.03	0.015 - 0.04	0.018 - 0.04	0.023 - 0.05	0.03 - 0.06	0.03 - 0.07	0.04 - 0.08	0.04 - 0.10

L'avance en plongée (Vfp) d'une fraise Z = 2 (perçage) doit être réduite de 40 à 80 % en fonction de la matière à usiner.

Avance par dent

Ø D ₁ 3.00 - 4.00	Ø D ₁ 4.00 - 5.00	Ø D ₁ 5.00 - 6.00	Ø D ₁ 6.00 - 7.00	Ø D ₁ 7.00 - 8.00	Ø D ₁ 8.00 - 10.00	Ø D ₁ 10.00 - 12.00	Ø D ₁ 12.00 - 14.00	Ø D ₁ 14.00 - 16.00	Ø D ₁ 16.00 - 20.00
0.011 - 0.03	0.014 - 0.04	0.018 - 0.05	0.021 - 0.05	0.025 - 0.06	0.032 - 0.08	0.04 - 0.09	0.04 - 0.11	0.05 - 0.12	0.06 - 0.15



CONDITIONS DE COUPE

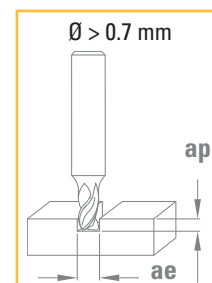
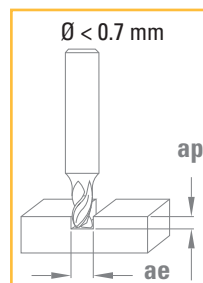

Matières à usiner

			CARBURE		CUTINOX		$\varnothing < 0.7 \text{ mm}$		$\varnothing > 0.7 \text{ mm}$	
			Vc [m/min]	Vc [m/min]	Vc [m/min]	Vc [m/min]	ap [mm]	ae [mm]	ap [mm]	ae [mm]
P	Acier non allié / faiblement allié	< 600 N/mm ²	50	80	80	120	0.8 x ØD1	< 1 x ØD1	1 x ØD1	< 1 x ØD1
P	Acier non allié / faiblement allié	600 – 1500 N/mm ²	30	60	70	100	0.6 x ØD1	< 1 x ØD1	1 x ØD1	< 1 x ØD1
P	Acier de décolletage au plomb		80	120	100	180	1 x ØD1	< 1 x ØD1	1 x ØD1	< 1 x ØD1
P	Acier fortement allié	700 – 1500 N/mm ²	30	50	40	70	0.5 x ØD1	< 1 x ØD1	0.8 x ØD1	< 1 x ØD1
M	Acier inoxydable	400 – 700 N/mm ²	40	60	60	90	0.5 x ØD1	< 1 x ØD1	0.8 x ØD1	< 1 x ØD1
M	Acier inox. DUPLEX, acier austénitique inox. sans nickel	> 800 N/mm ²	20	40	30	60	0.4 x ØD1	< 1 x ØD1	0.7 x ØD1	< 1 x ØD1
K	Fonte grise / Fonte à graphite sphéroïdal perlitique	< 250 HB	100	150	150	200	1 x ØD1	< 1 x ØD1	1 x ØD1	< 1 x ØD1
K	Fonte allié / Fonte à graphite sphéroïdal perlitique	> 250 HB	50	80	60	100	0.8 x ØD1	< 1 x ØD1	1 x ØD1	< 1 x ØD1
K	Fonte à graphite sphéroïdal ferritique / Fonte malléable		50	80	60	90	0.8 x ØD1	< 1 x ØD1	1 x ØD1	< 1 x ØD1
S	Super alliages / Acier inox. réfractaire	Inconel Nimonic Hastelloy	10	20	20	40	0.2 x ØD1	< 1 x ØD1	0.4 x ØD1	< 1 x ØD1
S	Titane, alliage de titane		30	60	40	70	0.8 x ØD1	< 1 x ØD1	1 x ØD1	< 1 x ØD1
N	Alliage de cuivre / bonne usinabilité (laiton – bronze)		150	250	100	250	1 x ØD1	< 1 x ØD1	1 x ØD1	< 1 x ØD1
N	Alliage de cuivre / usinabilité difficile / Bronze à l'aluminium	(CuAlFe) (Ampco)	80	150	80	150	0.8 x ØD1	< 1 x ØD1	1 x ØD1	< 1 x ØD1
N	Alliage d'aluminium	Si < 8%	150	300	150	300	1 x ØD1	< 1 x ØD1	1 x ØD1	< 1 x ØD1
N	Fonte d'aluminium	Si > 8%	100	150	150	250	3 x ØD1	< 1 x ØD1	1 x ØD1	< 1 x ØD1
N	Plastique		100	150	100	150	3 x ØD1	< 1 x ØD1	1 x ØD1	< 1 x ØD1
N	Or, argent		100	150	100	150	1 x ØD1	< 1 x ØD1	1 x ØD1	< 1 x ØD1

Les valeurs n et Vf sont indicatives et devront être ajustées en fonction de la longueur L₂ de l'outil



$$n \text{ [tr/min]} = \frac{Vc \text{ [m/min]} \times 1000}{\pi \times D_1 \text{ [mm]}}$$

$$Vf \text{ [mm/min]} = n \text{ [tr/min]} \times fz \text{ [mm]} \times Z$$

Avance par dent **fz [mm]**

$\emptyset D_1$ 0.30 - 0.50	$\emptyset D_1$ 0.60 - 0.90	$\emptyset D_1$ 1.00 - 2.00	$\emptyset D_1$ 2.00 - 4.00	$\emptyset D_1$ 4.00 - 6.00	$\emptyset D_1$ 6.00 - 8.00	$\emptyset D_1$ 80.00 - 10.00	
0.002 - 0.005	0.003 - 0.012	0.005 - 0.025	0.01 - 0.06	0.02 - 0.08	0.03 - 0.12	0.04 - 0.15	
0.001 - 0.004	0.003 - 0.01	0.005 - 0.02	0.01 - 0.04	0.02 - 0.06	0.03 - 0.08	0.04 - 0.10	
0.002 - 0.008	0.004 - 0.016	0.006 - 0.03	0.015 - 0.07	0.015 - 0.09	0.04 - 0.15	0.1 - 0.20	
0.001 - 0.003	0.002 - 0.01	0.003 - 0.015	0.008 - 0.03	0.03 - 0.04	0.03 - 0.06	0.04 - 0.08	
0.001 - 0.003	0.002 - 0.01	0.003 - 0.013	0.008 - 0.03	0.013 - 0.04	0.03 - 0.06	0.04 - 0.08	
0.001 - 0.003	0.002 - 0.008	0.003 - 0.01	0.004 - 0.02	0.008 - 0.03	0.01 - 0.04	0.02 - 0.05	
0.002 - 0.005	0.003 - 0.012	0.005 - 0.025	0.01 - 0.06	0.02 - 0.08	0.03 - 0.12	0.1 - 0.20	
0.001 - 0.002	0.003 - 0.015	0.005 - 0.02	0.01 - 0.04	0.02 - 0.06	0.03 - 0.08	0.04 - 0.10	
0.001 - 0.006	0.003 - 0.01	0.005 - 0.02	0.01 - 0.04	0.02 - 0.06	0.03 - 0.08	0.04 - 0.10	
0.001 - 0.002	0.0015 - 0.004	0.002 - 0.008	0.003 - 0.012	0.008 - 0.02	0.03 - 0.04	0.015 - 0.05	
0.001 - 0.005	0.003 - 0.012	0.005 - 0.025	0.01 - 0.04	0.02 - 0.06	0.03 - 0.08	0.04 - 0.10	
0.002 - 0.01	0.004 - 0.02	0.006 - 0.04	0.015 - 0.08	0.03 - 0.10	0.04 - 0.15	0.05 - 0.20	
0.002 - 0.008	0.003 - 0.015	0.005 - 0.03	0.01 - 0.06	0.02 - 0.08	0.03 - 0.10	0.04 - 0.15	
0.002 - 0.005	0.003 - 0.012	0.005 - 0.025	0.01 - 0.08	0.03 - 0.10	0.04 - 0.15	0.05 - 0.20	
0.002 - 0.015	0.004 - 0.025	0.006 - 0.05	0.015 - 0.06	0.02 - 0.08	0.03 - 0.12	0.04 - 0.15	
0.002 - 0.02	0.005 - 0.03	0.008 - 0.06	0.02 - 0.10	0.04 - 0.12	0.05 - 0.20	0.06 - 0.25	
0.002 - 0.01	0.003 - 0.02	0.006 - 0.05	0.015 - 0.06	0.02 - 0.08	0.03 - 0.10	0.04 - 0.15	



CONDITIONS DE COUPE

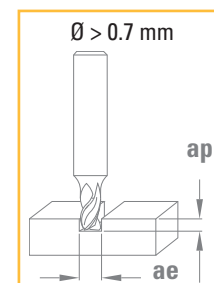
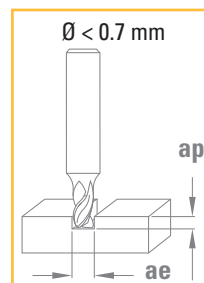

Matières à usiner

			CARBURE		CUTINOX		$\varnothing < 0.7 \text{ mm}$		$\varnothing > 0.7 \text{ mm}$	
			Vc [m/min]	Vc [m/min]	Vc [m/min]	Vc [m/min]	ap [mm]	ae [mm]	ap [mm]	ae [mm]
P	Acier non allié / faiblement allié	< 600 N/mm ²	50	80	80	120	0.4 x ØD1	< 1 x ØD1	0.5 x ØD1	< 1 x ØD1
P	Acier non allié / faiblement allié	600 – 1500 N/mm ²	30	60	70	100	0.3 x ØD1	< 1 x ØD1	0.5 x ØD1	< 1 x ØD1
P	Acier de décolletage au plomb		80	120	100	180	0.5 x ØD1	< 1 x ØD1	0.5 x ØD1	< 1 x ØD1
P	Acier fortement allié	700 – 1500 N/mm ²	30	50	40	70	0.25 x ØD1	< 1 x ØD1	0.4 x ØD1	< 1 x ØD1
M	Acier inoxydable	400 – 700 N/mm ²	40	60	60	90	0.25 x ØD1	< 1 x ØD1	0.4 x ØD1	< 1 x ØD1
M	Acier inox. DUPLEX, acier austénitique inox. sans nickel	> 800 N/mm ²	20	40	30	60	0.2 x ØD1	< 1 x ØD1	0.35 x ØD1	< 1 x ØD1
K	Fonte grise / Fonte à graphite sphéroïdal perlitique	< 250 HB	100	150	150	200	0.5 x ØD1	< 1 x ØD1	0.5 x ØD1	< 1 x ØD1
K	Fonte allié / Fonte à graphite sphéroïdal perlitique	> 250 HB	50	80	60	100	0.4 x ØD1	< 1 x ØD1	0.5 x ØD1	< 1 x ØD1
K	Fonte à graphite sphéroïdal ferritique / Fonte malléable		50	80	60	90	0.4 x ØD1	< 1 x ØD1	0.5 x ØD1	< 1 x ØD1
S	Super alliages / Acier inox. réfractaire	Inconel Nimonic Hastelloy	10	20	20	40	0.1 x ØD1	< 1 x ØD1	0.2 x ØD1	< 1 x ØD1
S	Titane, alliage de titane		30	60	40	70	0.4 x ØD1	< 1 x ØD1	0.5 x ØD1	< 1 x ØD1
N	Alliage de cuivre / bonne usinabilité (laiton – bronze)		150	250	100	250	0.5 x ØD1	< 1 x ØD1	0.5 x ØD1	< 1 x ØD1
N	Alliage de cuivre / usinabilité difficile / Bronze à l'aluminium	(CuAlFe) (Ampco)	80	150	80	150	0.4 x ØD1	< 1 x ØD1	0.5 x ØD1	< 1 x ØD1
N	Alliage d'aluminium	Si < 8%	150	300	150	300	0.5 x ØD1	< 1 x ØD1	0.5 x ØD1	< 1 x ØD1
N	Fonte d'aluminium	Si > 8%	100	150	150	250	1.5 x ØD1	< 1 x ØD1	0.5 x ØD1	< 1 x ØD1
N	Plastique		100	150	100	150	1.5 x ØD1	< 1 x ØD1	0.5 x ØD1	< 1 x ØD1
N	Or, argent		100	150	100	150	0.5 x ØD1	< 1 x ØD1	0.5 x ØD1	< 1 x ØD1

Les valeurs n et Vf sont indicatives et devront être ajustées en fonction de la longueur L₂ de l'outil



$$n \text{ [tr/min]} = \frac{Vc \text{ [m/min]} \times 1000}{\pi \times D_1 \text{ [mm]}}$$

$$Vf \text{ [mm/min]} = n \text{ [tr/min]} \times fz \text{ [mm]} \times Z$$

Avance par dent **fz [mm]**

$\emptyset D_1$ 0.30 - 0.50	$\emptyset D_1$ 0.60 - 0.90	$\emptyset D_1$ 1.00 - 2.00	$\emptyset D_1$ 2.00 - 4.00	$\emptyset D_1$ 4.00 - 6.00	$\emptyset D_1$ 6.00 - 8.00	$\emptyset D_1$ 80.00 - 10.00	
0.002 - 0.005	0.003 - 0.012	0.005 - 0.025	0.01 - 0.06	0.02 - 0.08	0.03 - 0.12	0.04 - 0.15	
0.001 - 0.004	0.003 - 0.01	0.005 - 0.02	0.01 - 0.04	0.02 - 0.06	0.03 - 0.08	0.04 - 0.10	
0.002 - 0.008	0.004 - 0.016	0.006 - 0.03	0.015 - 0.07	0.015 - 0.09	0.04 - 0.15	0.1 - 0.20	
0.001 - 0.003	0.002 - 0.01	0.003 - 0.015	0.008 - 0.03	0.03 - 0.04	0.03 - 0.06	0.04 - 0.08	
0.001 - 0.003	0.002 - 0.01	0.003 - 0.013	0.008 - 0.03	0.013 - 0.04	0.03 - 0.06	0.04 - 0.08	
0.001 - 0.003	0.002 - 0.008	0.003 - 0.01	0.004 - 0.02	0.008 - 0.03	0.01 - 0.04	0.02 - 0.05	
0.002 - 0.005	0.003 - 0.012	0.005 - 0.025	0.01 - 0.06	0.02 - 0.08	0.03 - 0.12	0.1 - 0.20	
0.001 - 0.002	0.003 - 0.015	0.005 - 0.02	0.01 - 0.04	0.02 - 0.06	0.03 - 0.08	0.04 - 0.10	
0.001 - 0.006	0.003 - 0.01	0.005 - 0.02	0.01 - 0.04	0.02 - 0.06	0.03 - 0.08	0.04 - 0.10	
0.001 - 0.002	0.0015 - 0.004	0.002 - 0.008	0.003 - 0.012	0.008 - 0.02	0.03 - 0.04	0.015 - 0.05	
0.001 - 0.005	0.003 - 0.012	0.005 - 0.025	0.01 - 0.04	0.02 - 0.06	0.03 - 0.08	0.04 - 0.10	
0.002 - 0.01	0.004 - 0.02	0.006 - 0.04	0.015 - 0.08	0.03 - 0.10	0.04 - 0.15	0.05 - 0.20	
0.002 - 0.008	0.003 - 0.015	0.005 - 0.03	0.01 - 0.06	0.02 - 0.08	0.03 - 0.10	0.04 - 0.15	
0.002 - 0.005	0.003 - 0.012	0.005 - 0.025	0.01 - 0.08	0.03 - 0.10	0.04 - 0.15	0.05 - 0.20	
0.002 - 0.015	0.004 - 0.025	0.006 - 0.05	0.015 - 0.06	0.02 - 0.08	0.03 - 0.12	0.04 - 0.15	
0.002 - 0.02	0.005 - 0.03	0.008 - 0.06	0.02 - 0.10	0.04 - 0.12	0.05 - 0.20	0.06 - 0.25	
0.002 - 0.01	0.003 - 0.02	0.006 - 0.05	0.015 - 0.06	0.02 - 0.08	0.03 - 0.10	0.04 - 0.15	



CONDITIONS DE COUPE

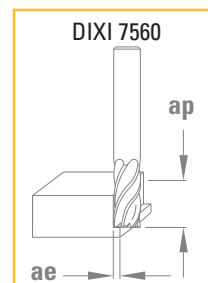

Matières à usiner

			CARBURE		TiAIN		DLC		ap [mm]	ae [mm]
			Vc [m/min]		Vc [m/min]		Vc [m/min]			
P	Acier non allié / faiblement allié	< 600 N/mm ²	90	110	110	130			1.50 x ØD1	< 0.10 x ØD1
P	Acier non allié / faiblement allié	600 – 1500 N/mm ²			80	100			1.50 x ØD1	< 0.10 x ØD1
P	Acier de décolletage au plomb		80	110					1.50 x ØD1	< 0.30 x ØD1
P	Acier fortement allié	700 – 1500 N/mm ²			60	80			1.50 x ØD1	< 0.05 x ØD1
M	Acier inoxydable	400 – 700 N/mm ²			80	100			1.50 x ØD1	< 0.05 x ØD1
M	Acier inox. DUPLEX, acier austénitique inox. sans nickel	> 800 N/mm ²			60	80			1.50 x ØD1	< 0.05 x ØD1
K	Fonte grise / Fonte à graphite sphéroïdal perlitique	< 250 HB	80	110	110	140			1.50 x ØD1	< 0.20 x ØD1
K	Fonte allié / Fonte à graphite sphéroïdal perlitique	> 250 HB	50	70	80	100			1.50 x ØD1	< 0.05 x ØD1
K	Fonte à graphite sphéroïdal ferritique / Fonte malléable		80	110	110	130			1.50 x ØD1	< 0.10 x ØD1
S	Super alliages / Acier inox. réfractaire	Inconel Nimonic Hastelloy			35	50			1.50 x ØD1	< 0.05 x ØD1
S	Titane, alliage de titane		40	55			50	80	1.50 x ØD1	< 0.10 x ØD1
N	Alliage de cuivre / bonne usinabilité (laiton – bronze)		160	200			200	300	1.50 x ØD1	< 0.30 x ØD1
N	Alliage de cuivre / usinabilité difficile / Bronze à l'aluminium (CuAlFe) (Ampco)		140	160	170	220	200	270	1.50 x ØD1	< 0.10 x ØD1

DIXI 7060 - 7063 - 7232

CONDITIONS DE COUPE

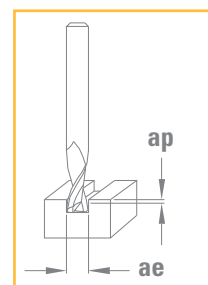

Matières à usiner

			CARBURE		ap [mm]	ae [mm]
			Vc [m/min]			
K	Fonte grise / Fonte à graphite sphéroïdal perlitique	< 250 HB	100	150	< 1 x ØD1	1 x ØD1
N	Alliage de cuivre / bonne usinabilité (laiton – bronze)		140	160	< 1 x ØD1	1 x ØD1
N	Plastique		140	160	< 0.9 x ØD1	1 x ØD1
N	Or, argent		240	260	< 1.2 x ØD1	1 x ØD1
N	Alliage d'aluminium	Si < 8%	240	300	< 1.2 x ØD1	1 x ØD1



$$n \text{ [tr/min]} = \frac{Vc \text{ [m/min]} \times 1000}{\pi \times D_1 \text{ [mm]}}$$

$$Vf \text{ [mm/min]} = n \text{ [tr/min]} \times fz \text{ [mm]} \times Z$$

Avance par dent **fz [mm]**

$\emptyset D_1$ 0.35 - 1.90 (Z = 3)	$\emptyset D_1$ 2.00 - 3.00 (Z = 5)	$\emptyset D_1$ 3.00 - 5.00 (Z = 5)	$\emptyset D_1$ 5.00 - 8.00 (Z = 5)	$\emptyset D_1$ 8.00 - 10.00 (Z = 6)	$\emptyset D_1$ 10.00 - 14.00 (Z = 6)	$\emptyset D_1$ 14.00 - 16.00 (Z = 6)	$\emptyset D_1$ 16.00 - 20.00 (Z = 6)
0.004 - 0.02	0.016 - 0.04	0.02 - 0.06	0.03 - 0.07	0.04 - 0.08	0.05 - 0.09	0.06 - 0.10	0.07 - 0.11
0.004 - 0.02	0.016 - 0.04	0.02 - 0.06	0.03 - 0.07	0.04 - 0.08	0.05 - 0.09	0.06 - 0.10	0.07 - 0.11
0.004 - 0.02	0.016 - 0.04	0.02 - 0.06	0.03 - 0.07	0.04 - 0.08	0.05 - 0.09	0.07 - 0.10	0.08 - 0.11
0.002 - 0.015	0.016 - 0.04	0.02 - 0.06	0.03 - 0.07	0.04 - 0.08	0.05 - 0.09	0.06 - 0.10	0.07 - 0.11
0.002 - 0.015	0.016 - 0.04	0.02 - 0.06	0.03 - 0.07	0.04 - 0.08	0.05 - 0.09	0.06 - 0.10	0.07 - 0.11
0.002 - 0.015	0.016 - 0.04	0.02 - 0.06	0.03 - 0.07	0.04 - 0.08	0.05 - 0.09	0.06 - 0.10	0.07 - 0.11
0.004 - 0.02	0.016 - 0.04	0.02 - 0.06	0.03 - 0.07	0.04 - 0.08	0.05 - 0.09	0.06 - 0.10	0.07 - 0.11
0.004 - 0.02	0.016 - 0.04	0.02 - 0.06	0.03 - 0.07	0.04 - 0.08	0.05 - 0.09	0.06 - 0.10	0.07 - 0.11
0.004 - 0.02	0.016 - 0.04	0.02 - 0.06	0.03 - 0.07	0.04 - 0.08	0.05 - 0.09	0.06 - 0.10	0.07 - 0.11
0.002 - 0.01	0.016 - 0.04	0.02 - 0.06	0.03 - 0.07	0.04 - 0.08	0.05 - 0.09	0.06 - 0.10	0.07 - 0.11
0.002 - 0.01	0.016 - 0.04	0.02 - 0.06	0.03 - 0.07	0.04 - 0.08	0.05 - 0.09	0.06 - 0.10	0.07 - 0.11
0.004 - 0.02	0.016 - 0.04	0.02 - 0.06	0.03 - 0.07	0.04 - 0.08	0.05 - 0.09	0.07 - 0.10	0.08 - 0.11
0.004 - 0.02	0.016 - 0.04	0.02 - 0.06	0.03 - 0.07	0.04 - 0.08	0.05 - 0.09	0.06 - 0.10	0.07 - 0.11

Avance par dent **fz [mm]**

$\emptyset D_1$ 0.40 - 1.00	$\emptyset D_1$ 1.00 - 1.50	$\emptyset D_1$ 1.50 - 3.00	$\emptyset D_1$ 3.00 - 5.00	$\emptyset D_1$ 5.00 - 7.00	$\emptyset D_1$ 7.00 - 10.00
0.006 - 0.015	0.012 - 0.020	0.016 - 0.04	0.02 - 0.06	0.03 - 0.09	0.04 - 0.11
0.006 - 0.015	0.012 - 0.020	0.016 - 0.04	0.02 - 0.06	0.03 - 0.09	0.04 - 0.11
0.006 - 0.015	0.012 - 0.020	0.016 - 0.04	0.02 - 0.06	0.03 - 0.09	0.04 - 0.11
0.006 - 0.015	0.012 - 0.020	0.016 - 0.04	0.02 - 0.06	0.03 - 0.09	0.04 - 0.11
0.006 - 0.015	0.012 - 0.020	0.016 - 0.04	0.02 - 0.06	0.03 - 0.09	0.04 - 0.11



CONDITIONS DE COUPE

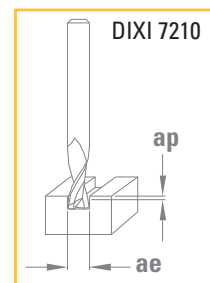
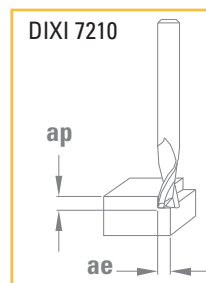

Matières à usiner

			CARBURE		CUTINOX		ap	ae	ap	ae
			Vc [m/min]	Vc [m/min]	[mm]	[mm]	[mm]	[mm]		
P	Acier non allié / faiblement allié	< 600 N/mm ²	70	100	100	120	1.5 x ØD1	0.5 x ØD1	< 1.3 x ØD1	1 x ØD1
P	Acier non allié / faiblement allié	600 – 1500 N/mm ²			80	100	1.5 x ØD1	0.5 x ØD1	< 1.0 x ØD1	1 x ØD1
P	Acier de décolletage au plomb		70	100			1.5 x ØD1	0.5 x ØD1	< 1.0 x ØD1	1 x ØD1
P	Acier fortement allié	700 – 1500 N/mm ²			50	70	1.5 x ØD1	0.5 x ØD1	< 1.0 x ØD1	1 x ØD1
M	Acier inoxydable	400 – 700 N/mm ²			80	100	1.5 x ØD1	0.5 x ØD1	< 1.0 x ØD1	1 x ØD1
K	Fonte grise / Fonte à graphite sphéroïdal perlitique	< 250 HB	70	100	100	120	1.5 x ØD1	0.5 x ØD1	< 1.0 x ØD1	1 x ØD1
K	Fonte alliée / Fonte à graphite sphéroïdal perlitique	> 250 HB	40	70	80	100	1.5 x ØD1	0.5 x ØD1	< 1.0 x ØD1	1 x ØD1
K	Fonte à graphite sphéroïdal ferritique / Fonte malléable		70	100	100	120	1.5 x ØD1	0.5 x ØD1	< 1.0 x ØD1	1 x ØD1
S	Titane, alliage de titane		30	45			1.5 x ØD1	0.5 x ØD1	< 1.0 x ØD1	1 x ØD1
N	Alliage de cuivre / bonne usinabilité (laiton – bronze)		160	180	220	240	1.0 x ØD1	1.0 x ØD1	< 1.5 x ØD1	0.5 x ØD1
N	Alliage de cuivre / usinabilité difficile / Bronze à l'aluminium (CuAlFe)		100	130	120	150	1.0 x ØD1	1.0 x ØD1	< 1.5 x ØD1	0.5 x ØD1
N	Alliage d'aluminium	Si < 8%	130	250	200	300	1.5 x ØD1	0.5 x ØD1	< 1.0 x ØD1	
N	Or, argent		140	160	200	220	< 1.0 x ØD1	1 x ØD1	< 1.5 x ØD1	< 0.5 x ØD1

DIXI 7301 - 7302 - 7303

CONDITIONS DE COUPE

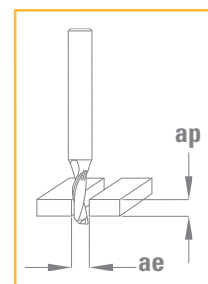

Matières à usiner

		CARBURE		ap	ae
		Vc [m/min]	Vc [m/min]	[mm]	[mm]
N	Plastique	130	200	< 1.5 x ØD1	1 x ØD1

L'avance en plongée (Vfp) d'une fraise Z = 1 (perçage) doit être réduite de 40 à 80 % en fonction de la matière à usiner.



CONDITIONS DE COUPE

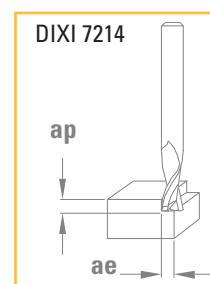
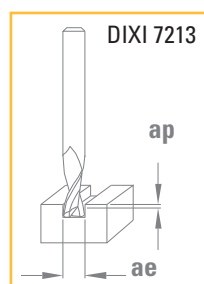

Matières à usiner

			CARBURE		TiAlN		ap [mm]	ae [mm]	ap [mm]	ae [mm]
			Vc [m/min]	Vc [m/min]	Vc [m/min]	Vc [m/min]				
P	Acier non allié / faiblement allié	< 600 N/mm ²	70	100	90	110	< 1.0 x ØD1	1 x ØD1	< 1 x ØD1	< 0.5 x ØD1
P	Acier non allié / faiblement allié	600 – 1500 N/mm ²			70	90	< 0.5 x ØD1	1 x ØD1	< 1 x ØD1	< 0.3 x ØD1
P	Acier de décolletage au plomb		70	100			< 1.0 x ØD1	1 x ØD1	< 1.5 x ØD1	< 0.5 x ØD1
P	Acier fortement allié	700 – 1500 N/mm ²			40	60	< 0.5 x ØD1	1 x ØD1	< 1 x ØD1	< 0.3 x ØD1
M	Acier inoxydable	400 – 700 N/mm ²			80	100	< 0.5 x ØD1	1 x ØD1	< 1 x ØD1	< 0.3 x ØD1
K	Fonte grise / Fonte à graphite sphéroïdal perlitique	< 250 HB	70	100	90	110	< 1.0 x ØD1	1 x ØD1	< 1 x ØD1	< 0.5 x ØD1
K	Fonte allié / Fonte à graphite sphéroïdal perlitique	> 250 HB	40	70	70	90	< 0.4 x ØD1	1 x ØD1	< 1 x ØD1	< 0.4 x ØD1
K	Fonte à graphite sphéroïdal ferritique / Fonte malléable		70	100	90	110	< 0.4 x ØD1	1 x ØD1	< 1 x ØD1	< 0.4 x ØD1
S	Titane, alliage de titane		30	45			< 0.5 x ØD1	1 x ØD1	< 1 x ØD1	< 0.3 x ØD1
N	Alliage de cuivre / bonne usinabilité (laiton – bronze)		140	160			< 2.0 x ØD1	1 x ØD1	< 1.5 x ØD1	< 0.5 x ØD1
N	Alliage de cuivre / usinabilité difficile / Bronze à l'aluminium (CuAlFe) (Ampco)		120	140	170	190	< 1.0 x ØD1	1 x ØD1	< 1 x ØD1	< 0.3 x ØD1
N	Alliage d'aluminium	Si < 8%	180	260	230	340	< 2.0 x ØD1	1 x ØD1	< 1.5 x ØD1	< 0.5 x ØD1
N	Fonte d'aluminium	Si > 8%	140	160	210	230	< 2.0 x ØD1	1 x ØD1	< 1.5 x ØD1	< 0.5 x ØD1
N	Or, argent		140	160	200	220	< 1.0 x ØD1	1 x ØD1	< 1.5 x ØD1	< 0.5 x ØD1



$$n \text{ [tr/min]} = \frac{Vc \text{ [m/min]} \times 1000}{\pi \times D_1 \text{ [mm]}}$$

$$Vf \text{ [mm/min]} = n \text{ [tr/min]} \times fz \text{ [mm]} \times Z$$

Avance par dent **fz [mm]**

∅ D ₁ 4.00 - 5.00	∅ D ₁ 5.00 - 6.00	∅ D ₁ 6.00 - 7.00	∅ D ₁ 7.00 - 8.00	∅ D ₁ 8.00 - 9.00	∅ D ₁ 9.00 - 10.00	∅ D ₁ 10.00 - 12.00	∅ D ₁ 12.00 - 14.00	∅ D ₁ 14.00 - 16.00	∅ D ₁ 16.00 - 20.00
0.008 - 0.02	0.010 - 0.02	0.012 - 0.02	0.014 - 0.03	0.016 - 0.03	0.018 - 0.04	0.020 - 0.04	0.02 - 0.05	0.03 - 0.06	0.03 - 0.07
0.006 - 0.01	0.008 - 0.02	0.009 - 0.02	0.011 - 0.02	0.012 - 0.02	0.014 - 0.03	0.015 - 0.03	0.02 - 0.04	0.02 - 0.04	0.02 - 0.05
0.010 - 0.03	0.013 - 0.03	0.015 - 0.04	0.018 - 0.04	0.020 - 0.05	0.023 - 0.05	0.025 - 0.06	0.03 - 0.07	0.04 - 0.08	0.04 - 0.10
0.006 - 0.01	0.008 - 0.02	0.009 - 0.02	0.011 - 0.02	0.012 - 0.02	0.014 - 0.03	0.015 - 0.03	0.02 - 0.04	0.02 - 0.04	0.02 - 0.05
0.006 - 0.01	0.008 - 0.02	0.009 - 0.02	0.011 - 0.02	0.012 - 0.02	0.014 - 0.03	0.015 - 0.03	0.02 - 0.04	0.02 - 0.04	0.02 - 0.05
0.008 - 0.02	0.010 - 0.02	0.012 - 0.02	0.014 - 0.03	0.016 - 0.03	0.018 - 0.04	0.020 - 0.04	0.02 - 0.05	0.03 - 0.06	0.03 - 0.07
0.006 - 0.01	0.008 - 0.02	0.009 - 0.02	0.011 - 0.02	0.012 - 0.02	0.014 - 0.03	0.015 - 0.03	0.02 - 0.04	0.02 - 0.04	0.02 - 0.05
0.008 - 0.02	0.010 - 0.02	0.012 - 0.02	0.014 - 0.03	0.016 - 0.03	0.018 - 0.04	0.020 - 0.04	0.02 - 0.05	0.03 - 0.06	0.03 - 0.07
0.006 - 0.01	0.008 - 0.02	0.009 - 0.02	0.011 - 0.02	0.012 - 0.02	0.014 - 0.03	0.015 - 0.03	0.02 - 0.04	0.02 - 0.04	0.02 - 0.05
0.010 - 0.03	0.013 - 0.03	0.015 - 0.04	0.018 - 0.04	0.020 - 0.05	0.023 - 0.05	0.025 - 0.06	0.03 - 0.07	0.04 - 0.08	0.04 - 0.10
0.006 - 0.01	0.008 - 0.02	0.009 - 0.02	0.011 - 0.02	0.012 - 0.02	0.014 - 0.03	0.015 - 0.03	0.02 - 0.04	0.02 - 0.04	0.02 - 0.05
0.010 - 0.03	0.013 - 0.03	0.015 - 0.04	0.018 - 0.04	0.020 - 0.05	0.023 - 0.05	0.025 - 0.06	0.03 - 0.07	0.04 - 0.08	0.04 - 0.10
0.010 - 0.03	0.013 - 0.03	0.015 - 0.04	0.018 - 0.04	0.020 - 0.05	0.023 - 0.05	0.025 - 0.06	0.03 - 0.07	0.04 - 0.08	0.04 - 0.10
0.010 - 0.03	0.013 - 0.03	0.015 - 0.04	0.018 - 0.04	0.020 - 0.05	0.023 - 0.05	0.025 - 0.06	0.03 - 0.07	0.04 - 0.08	0.04 - 0.10



CONDITIONS DE COUPE

Tréflage

Matières à usiner	XIDUR Vc [m/min]	ap [mm]
P Acier non allié / faiblement allié < 600 N/mm ²	175	<1xØD ₁
P Acier non allié / faiblement allié 600 – 1500 N/mm ²	140	<1xØD ₁
P Acier de décolletage au plomb	175	<1xØD ₁
P Acier fortement allié 700 – 1500 N/mm ²	140	<1xØD ₁
H Acier à outils >50HRC	50	<0.8xØD ₁
M Acier inoxydable 400 – 700 N/mm ²	80	<0.8xØD ₁
M Acier inox. DUPLEX, acier austénitique inox. sans nickel > 800 N/mm ²	60	<1xØD ₁
K Fonte grise / Fonte à graphite sphéroïdal perlitique < 250 HB	110	<1xØD ₁
K Fonte alliée / Fonte à graphite sphéroïdal perlitique > 250 HB	70	<1xØD ₁
K Fonte à graphite sphéroïdal ferritique / Fonte malléable	80	<1xØD ₁
S Super alliages / Acier inox. réfractaire	80	<0.8xØD ₁
S Titane, alliage de titane	70	<0.8xØD ₁

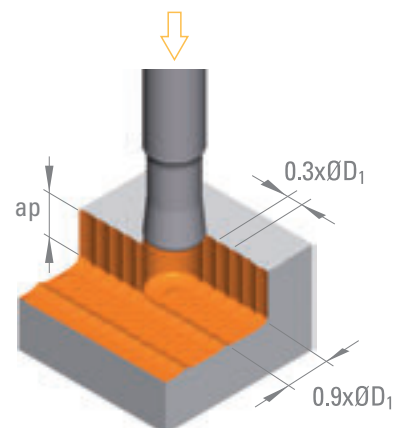

Descente en rampe

Matières à usiner	XIDUR Vc [m/min]	α [°]
P Acier non allié / faiblement allié < 600 N/mm ²	200	<1xØD ₁
P Acier non allié / faiblement allié 600 – 1500 N/mm ²	150	0.75
P Acier de décolletage au plomb	200	0.75
P Acier fortement allié 700 – 1500 N/mm ²	150	0.75
H Acier à outils >50HRC	200	0.75
M Acier inoxydable 400 – 700 N/mm ²	110	0.50
M Acier inox. DUPLEX, acier austénitique inox. sans nickel > 800 N/mm ²	80	0.50
K Fonte grise / Fonte à graphite sphéroïdal perlitique < 250 HB	150	0.75
K Fonte alliée / Fonte à graphite sphéroïdal perlitique > 250 HB	100	0.75
K Fonte à graphite sphéroïdal ferritique / Fonte malléable	80	0.75
S Super alliages / Acier inox. réfractaire	60	0.50
S Titane, alliage de titane	80	0.50

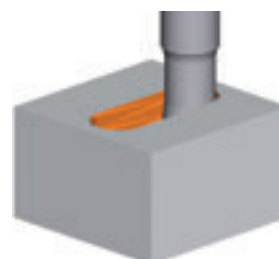
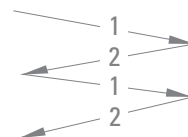

Calcul des valeurs de la rampe:

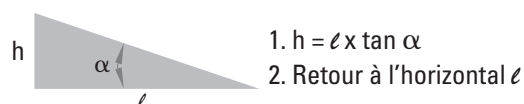

Interpolation hélicoïdale

Matières à usiner	XIDUR Vc [m/min]	α [°]
P Acier non allié / faiblement allié < 600 N/mm ²	250	0.75
P Acier non allié / faiblement allié 600 – 1500 N/mm ²	200	0.75
P Acier de décolletage au plomb	250	0.75
P Acier fortement allié 700 – 1500 N/mm ²	200	0.75
H Acier à outils >50HRC	200	0.75
M Acier inoxydable 400 – 700 N/mm ²	150	0.50
M Acier inox. DUPLEX, acier austénitique inox. sans nickel > 800 N/mm ²	110	0.50
K Fonte grise / Fonte à graphite sphéroïdal perlitique < 250 HB	150	0.75
K Fonte alliée / Fonte à graphite sphéroïdal perlitique > 250 HB	100	0.75
K Fonte à graphite sphéroïdal ferritique / Fonte malléable	80	0.75
S Super alliages / Acier inox. réfractaire	80	0.50
S Titane, alliage de titane	100	0.50

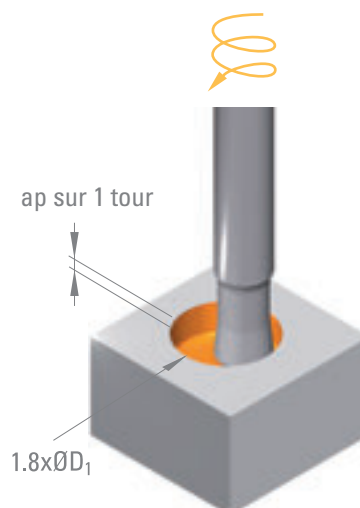

Calcul des valeurs d'hélice:

$ap \text{ sur 1 tour} = \pi \times D_1 \times \tan \alpha$



Avance par dent **fz [mm]**

Ø D ₁	Ø D ₁	Ø D ₁	Ø D ₁	Ø D ₁	Ø D ₁	Ø D ₁	Ø D ₁	Ø D ₁	Ø D ₁	Ø D ₁	Ø D ₁
0.50	0.80	1.00	1.50	2.00	3.00	4.00	5.00	6.00	8.00	10.00	12.00
0.004	0.006	0.008	0.012	0.016	0.024	0.032	0.040	0.048	0.064	0.080	0.096
0.003	0.005	0.006	0.010	0.013	0.019	0.026	0.032	0.038	0.051	0.064	0.077
0.004	0.006	0.008	0.012	0.016	0.024	0.032	0.040	0.048	0.064	0.080	0.096
0.003	0.005	0.006	0.010	0.013	0.019	0.026	0.032	0.038	0.051	0.064	0.077
0.003	0.004	0.006	0.008	0.011	0.017	0.022	0.028	0.034	0.045	0.056	0.067
0.003	0.004	0.006	0.008	0.011	0.017	0.022	0.028	0.034	0.045	0.056	0.067
0.003	0.004	0.006	0.008	0.011	0.017	0.022	0.028	0.034	0.045	0.056	0.067
0.004	0.006	0.008	0.012	0.016	0.024	0.032	0.040	0.048	0.064	0.080	0.096
0.003	0.005	0.006	0.010	0.013	0.019	0.026	0.032	0.038	0.051	0.064	0.077
0.003	0.004	0.006	0.008	0.011	0.017	0.022	0.028	0.034	0.045	0.056	0.067
0.002	0.004	0.005	0.007	0.010	0.014	0.019	0.024	0.029	0.038	0.048	0.058
0.003	0.004	0.006	0.008	0.011	0.017	0.022	0.028	0.034	0.045	0.056	0.067

Avance par dent **fz [mm]**

Ø D ₁	Ø D ₁	Ø D ₁	Ø D ₁	Ø D ₁	Ø D ₁	Ø D ₁	Ø D ₁	Ø D ₁	Ø D ₁	Ø D ₁	Ø D ₁
0.50	0.80	1.00	1.50	2.00	3.00	4.00	5.00	6.00	8.00	10.00	12.00
0.013	0.021	0.026	0.040	0.053	0.079	0.106	0.132	0.158	0.211	0.264	0.317
0.012	0.019	0.024	0.036	0.048	0.072	0.096	0.120	0.144	0.192	0.240	0.288
0.013	0.021	0.026	0.040	0.053	0.079	0.106	0.132	0.158	0.211	0.264	0.317
0.012	0.019	0.024	0.036	0.048	0.072	0.096	0.120	0.144	0.192	0.240	0.288
0.004	0.006	0.008	0.012	0.016	0.024	0.032	0.040	0.048	0.064	0.080	0.096
0.010	0.015	0.019	0.029	0.038	0.058	0.077	0.096	0.115	0.154	0.192	0.230
0.010	0.015	0.019	0.029	0.038	0.058	0.077	0.096	0.115	0.154	0.192	0.230
0.010	0.015	0.019	0.029	0.038	0.058	0.077	0.096	0.115	0.154	0.192	0.230
0.007	0.012	0.014	0.022	0.029	0.043	0.058	0.072	0.086	0.115	0.144	0.173
0.006	0.010	0.013	0.019	0.026	0.038	0.051	0.064	0.077	0.102	0.128	0.154
0.007	0.012	0.014	0.022	0.029	0.043	0.058	0.072	0.086	0.115	0.144	0.173
0.008	0.013	0.017	0.025	0.034	0.050	0.067	0.084	0.101	0.134	0.168	0.202

Avance par dent **fz [mm]**

Ø D ₁	Ø D ₁	Ø D ₁	Ø D ₁	Ø D ₁	Ø D ₁	Ø D ₁	Ø D ₁	Ø D ₁	Ø D ₁	Ø D ₁	Ø D ₁
0.50	0.80	1.00	1.50	2.00	3.00	4.00	5.00	6.00	8.00	10.00	12.00
0.018	0.028	0.035	0.053	0.070	0.106	0.141	0.176	0.211	0.282	0.352	0.422
0.016	0.026	0.032	0.048	0.064	0.096	0.128	0.160	0.192	0.256	0.320	0.384
0.018	0.028	0.035	0.053	0.070	0.106	0.141	0.176	0.211	0.282	0.352	0.422
0.016	0.026	0.032	0.048	0.064	0.096	0.128	0.160	0.192	0.256	0.320	0.384
0.005	0.008	0.010	0.014	0.019	0.029	0.038	0.048	0.058	0.077	0.096	0.115
0.013	0.020	0.026	0.038	0.051	0.077	0.102	0.128	0.154	0.205	0.256	0.307
0.013	0.020	0.026	0.038	0.051	0.077	0.102	0.128	0.154	0.205	0.256	0.307
0.013	0.020	0.026	0.038	0.051	0.077	0.102	0.128	0.154	0.205	0.256	0.307
0.010	0.015	0.019	0.029	0.038	0.058	0.077	0.096	0.115	0.154	0.192	0.230
0.010	0.015	0.019	0.029	0.038	0.058	0.077	0.096	0.115	0.154	0.192	0.230
0.008	0.012	0.015	0.023	0.030	0.046	0.061	0.076	0.091	0.122	0.152	0.182
0.011	0.018	0.022	0.034	0.045	0.067	0.090	0.112	0.134	0.179	0.224	0.269



CONDITIONS DE COUPE

Contournage

Matières à usiner	XIDUR Vc [m/min]	ap [mm]
P Acier non allié / faiblement allié < 600 N/mm ²	250	<0.5xØD ₁
P Acier non allié / faiblement allié 600 – 1500 N/mm ²	200	<0.5xØD ₁
P Acier de décolletage au plomb	250	<0.5xØD ₁
P Acier fortement allié 700 – 1500 N/mm ²	200	<0.5xØD ₁
H Acier à outils >50HRC	200	<0.4xØD ₁
M Acier inoxydable 400 – 700 N/mm ²	150	<0.4xØD ₁
M Acier inox. DUPLEX, acier austénitique inox. sans nickel > 800 N/mm ²	110	<0.4xØD ₁
K Fonte grise / Fonte à graphite sphéroïdal perlitique < 250 HB	150	<0.5xØD ₁
K Fonte alliée / Fonte à graphite sphéroïdal perlitique > 250 HB	100	<0.5xØD ₁
K Fonte à graphite sphéroïdal ferritique / Fonte malléable	80	<0.5xØD ₁
S Super alliages / Acier inox. réfractaire	80	<0.4xØD ₁
S Titane, alliage de titane	100	<0.4xØD ₁

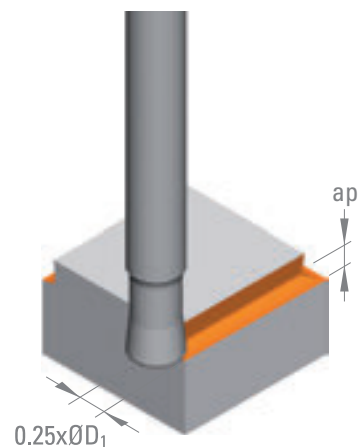

Surfaçage

Matières à usiner	XIDUR Vc [m/min]	ap [mm]
P Acier non allié / faiblement allié < 600 N/mm ²	250	<1x ε
P Acier non allié / faiblement allié 600 – 1500 N/mm ²	200	<1x ε
P Acier de décolletage au plomb	250	<1x ε
P Acier fortement allié 700 – 1500 N/mm ²	200	<1x ε
H Acier à outils >50HRC	200	<0.8x ε
M Acier inoxydable 400 – 700 N/mm ²	150	<0.8x ε
M Acier inox. DUPLEX, acier austénitique inox. sans nickel > 800 N/mm ²	110	<0.8x ε
K Fonte grise / Fonte à graphite sphéroïdal perlitique < 250 HB	150	<1x ε
K Fonte alliée / Fonte à graphite sphéroïdal perlitique > 250 HB	100	<1x ε
K Fonte à graphite sphéroïdal ferritique / Fonte malléable	80	<1x ε
S Super alliages / Acier inox. réfractaire	80	<0.5x ε
S Titane, alliage de titane	100	<0.5x ε

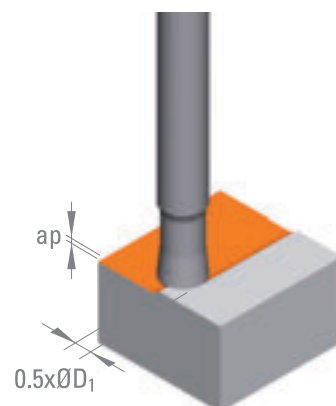

Cet outil ne possède pas de coupe au centre.

La valeur ε, en fonction du diamètre de l'outil, est un maximum.

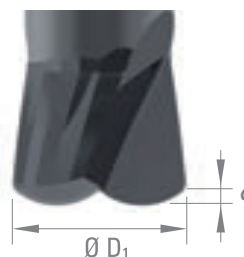

Avance par dent **fz [mm]**

Ø D ₁	Ø D ₁	Ø D ₁	Ø D ₁	Ø D ₁	Ø D ₁	Ø D ₁	Ø D ₁	Ø D ₁	Ø D ₁	Ø D ₁	Ø D ₁
0.50	0.80	1.00	1.50	2.00	3.00	4.00	5.00	6.00	8.00	10.00	12.00
0.010	0.017	0.021	0.031	0.042	0.062	0.083	0.104	0.125	0.166	0.208	0.250
0.010	0.015	0.019	0.029	0.038	0.058	0.077	0.096	0.115	0.154	0.192	0.230
0.010	0.017	0.021	0.031	0.042	0.062	0.083	0.104	0.125	0.166	0.208	0.250
0.010	0.015	0.019	0.029	0.038	0.058	0.077	0.096	0.115	0.154	0.192	0.230
0.005	0.008	0.010	0.014	0.019	0.029	0.038	0.048	0.058	0.077	0.096	0.115
0.008	0.013	0.016	0.024	0.032	0.048	0.064	0.080	0.096	0.128	0.160	0.192
0.008	0.013	0.016	0.024	0.032	0.048	0.064	0.080	0.096	0.128	0.160	0.192
0.008	0.013	0.016	0.024	0.032	0.048	0.064	0.080	0.096	0.128	0.160	0.192
0.006	0.009	0.011	0.017	0.022	0.034	0.045	0.056	0.067	0.090	0.112	0.134
0.005	0.008	0.010	0.016	0.021	0.031	0.042	0.052	0.062	0.083	0.104	0.125
0.006	0.009	0.011	0.017	0.022	0.034	0.045	0.056	0.067	0.090	0.112	0.134
0.007	0.011	0.014	0.020	0.027	0.041	0.054	0.068	0.082	0.109	0.136	0.163

Avance par dent **fz [mm]**

Ø D ₁	Ø D ₁	Ø D ₁	Ø D ₁	Ø D ₁	Ø D ₁	Ø D ₁	Ø D ₁	Ø D ₁	Ø D ₁	Ø D ₁	Ø D ₁
0.50	0.80	1.00	1.50	2.00	3.00	4.00	5.00	6.00	8.00	10.00	12.00
0.022	0.035	0.044	0.066	0.088	0.132	0.176	0.220	0.264	0.352	0.440	0.528
0.020	0.032	0.040	0.060	0.080	0.120	0.160	0.200	0.240	0.320	0.400	0.480
0.022	0.035	0.044	0.066	0.088	0.132	0.176	0.220	0.264	0.352	0.440	0.528
0.020	0.032	0.040	0.060	0.080	0.120	0.160	0.200	0.240	0.320	0.400	0.480
0.006	0.010	0.012	0.018	0.024	0.036	0.048	0.060	0.072	0.096	0.120	0.144
0.016	0.026	0.032	0.048	0.064	0.096	0.128	0.160	0.192	0.256	0.320	0.384
0.016	0.026	0.032	0.048	0.064	0.096	0.128	0.160	0.192	0.256	0.320	0.384
0.016	0.026	0.032	0.048	0.064	0.096	0.128	0.160	0.192	0.256	0.320	0.384
0.012	0.019	0.024	0.036	0.048	0.072	0.096	0.120	0.144	0.192	0.240	0.288
0.012	0.019	0.024	0.036	0.048	0.072	0.096	0.120	0.144	0.192	0.240	0.288
0.010	0.015	0.019	0.029	0.038	0.058	0.077	0.096	0.115	0.154	0.192	0.230
0.014	0.022	0.028	0.042	0.056	0.084	0.112	0.140	0.168	0.224	0.280	0.336
0.025	0.04	0.05	0.10	0.15	0.20	0.25	0.30	0.35	0.40	0.45	0.50

Valeur ζ

Téléchargez les conditions de coupe (pdf + xls) et les profils dxf



CONDITIONS DE COUPE

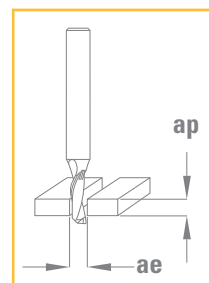

Matières à usiner

		CARBURE Vc [m/min]		ap [mm]	ae [mm]
P	Acier de décolletage au plomb	80	100	< 0.7 x ØD1	1 x ØD1
N	Alliage de cuivre / bonne usinabilité (laiton – bronze)	100	130	< 1 x ØD1	1 x ØD1
N	Alliage d'aluminium Si < 8%	120	160	< 1 x ØD1	1 x ØD1
N	Fonte d'aluminium Si > 8%	100	130	< 1 x ØD1	1 x ØD1
N	Plastique	130	200	< 1.5 x ØD1	1 x ØD1

L'avance en plongée (Vfp) d'une fraise Z = 1 (perçage) doit être réduite de 40 à 80 % en fonction de la matière à usiner.

DIXI 7552 - 7562 - 7572 - 7582

CONDITIONS DE COUPE

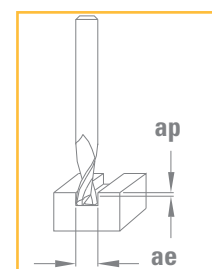

Matières à usiner

		CARBURE		TiAlN	DICUT	DIAMANT	ap [mm]	ae [mm]	
		Vc [m/min]	Vc [m/min]	Vc [m/min]	Vc [m/min]	Vc [m/min]			
P	Acier non allié / faiblement allié < 600 N/mm ²	50	80				< 1 x ØD1	< 1 x ØD1	
P	Acier non allié / faiblement allié 600 – 1500 N/mm ²			70	100		< 0.5 x ØD1	< 1 x ØD1	
P	Acier fortement allié 700 – 1500 N/mm ²			40	60		< 0.5 x ØD1	< 1 x ØD1	
K	Fonte grise / Fonte à graphite sphéroïdal perlitique < 250 HB	100	170				< 1 x ØD1	< 1 x ØD1	
S	Titane, alliage de titane	60	80				< 1 x ØD1	< 1 x ØD1	
N	Alliage de cuivre / bonne usinabilité (laiton – bronze)	80	120				< 1.5 x ØD1	< 1 x ØD1	
N	Alliage de cuivre / usinabilité difficile / Bronze à l'aluminium (CuAlFe) (Ampco)				100	140	< 1 x ØD1	< 1 x ØD1	
N	Alliage d'aluminium Si < 8%	150	200				< 1.5 x ØD1	< 1 x ØD1	
N	Fonte d'aluminium Si > 8%	100	200				< 1 x ØD1	< 1 x ØD1	
N	Graphite					200	300	3 x ØD1	< 0.30 x ØD1
N	Plastique	100	130				< 2 x ØD1	< 1 x ØD1	
N	Or, argent	90	130	100	140		< 0.5 x ØD1	< 1 x ØD1	



$$n \text{ [tr/min]} = \frac{V_c \text{ [m/min]} \times 1000}{\pi \times D_1 \text{ [mm]}}$$

$$V_f \text{ [mm/min]} = n \text{ [tr/min]} \times f_z \text{ [mm]} \times Z$$

Avance par dent **fz [mm]**

∅ D ₁ 2.00 - 2.50	∅ D ₁ 2.50 - 3.00	∅ D ₁ 3.00 - 4.00	∅ D ₁ 4.00 - 5.00	∅ D ₁ 5.00 - 6.00	∅ D ₁ 6.00 - 8.00	∅ D ₁ 8.00 - 10.00	∅ D ₁ 10.00 - 12.00
0.010 - 0.03	0.013 - 0.04	0.02 - 0.05	0.02 - 0.06	0.03 - 0.07	0.03 - 0.10	0.04 - 0.12	0.05 - 0.17
0.014 - 0.04	0.018 - 0.05	0.02 - 0.06	0.03 - 0.08	0.04 - 0.09	0.04 - 0.12	0.06 - 0.15	0.07 - 0.21
0.014 - 0.04	0.018 - 0.05	0.02 - 0.06	0.03 - 0.08	0.04 - 0.09	0.04 - 0.12	0.06 - 0.15	0.07 - 0.21
0.014 - 0.04	0.018 - 0.05	0.02 - 0.06	0.03 - 0.08	0.04 - 0.09	0.04 - 0.12	0.06 - 0.15	0.07 - 0.21
0.020 - 0.05	0.025 - 0.06	0.03 - 0.08	0.04 - 0.10	0.05 - 0.12	0.06 - 0.16	0.08 - 0.20	0.10 - 0.28

Avance par dent **fz [mm]**

∅ D ₁ 1.00 - 2.00	∅ D ₁ 2.00 - 3.00	∅ D ₁ 3.00 - 5.00	∅ D ₁ 5.00 - 7.00	∅ D ₁ 7.00 - 10.00	∅ D ₁ 10.00 - 13.00	∅ D ₁ 13.00 - 16.00	∅ D ₁ 16.00 - 20.00
0.012 - 0.02	0.018 - 0.04	0.03 - 0.06	0.04 - 0.09	0.07 - 0.12	0.06 - 0.14	0.07 - 0.16	0.08 - 0.20
0.012 - 0.02	0.018 - 0.04	0.03 - 0.06	0.04 - 0.09	0.07 - 0.12	0.06 - 0.14	0.07 - 0.16	0.08 - 0.20
0.012 - 0.02	0.018 - 0.04	0.03 - 0.06	0.04 - 0.09	0.07 - 0.12	0.06 - 0.14	0.07 - 0.16	0.08 - 0.20
0.012 - 0.02	0.018 - 0.04	0.03 - 0.06	0.04 - 0.09	0.07 - 0.12	0.06 - 0.14	0.07 - 0.16	0.08 - 0.20
0.012 - 0.02	0.018 - 0.04	0.03 - 0.06	0.04 - 0.09	0.07 - 0.12	0.06 - 0.14	0.07 - 0.16	0.08 - 0.20
0.012 - 0.02	0.018 - 0.04	0.03 - 0.06	0.04 - 0.09	0.07 - 0.12	0.06 - 0.14	0.07 - 0.16	0.08 - 0.20
0.012 - 0.02	0.018 - 0.04	0.03 - 0.06	0.04 - 0.09	0.07 - 0.12	0.06 - 0.14	0.07 - 0.16	0.08 - 0.20
0.012 - 0.02	0.018 - 0.04	0.03 - 0.06	0.04 - 0.09	0.07 - 0.12	0.06 - 0.14	0.07 - 0.16	0.08 - 0.20
0.014 - 0.04	0.018 - 0.05	0.021 - 0.05	0.025 - 0.06	0.032 - 0.08	0.04 - 0.09	0.04 - 0.11	0.05 - 0.12
0.012 - 0.02	0.018 - 0.04	0.03 - 0.06	0.04 - 0.09	0.07 - 0.12	0.06 - 0.14	0.07 - 0.16	0.08 - 0.20
0.012 - 0.02	0.018 - 0.04	0.03 - 0.06	0.04 - 0.09	0.07 - 0.12	0.06 - 0.14	0.07 - 0.16	0.08 - 0.20



DIXI 7543

CONDITIONS DE COUPE

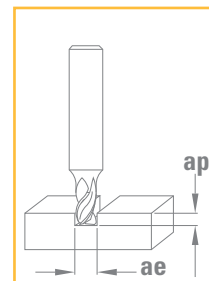

Matières à usiner

			XIDUR		ap [mm]	ae [mm]
			Vc [m/min]			
P	Acier non allié / faiblement allié	< 600 N/mm ²	90	110	< 1.0 x ØD1	1 x ØD1
P	Acier non allié / faiblement allié	600 – 1500 N/mm ²	70	90	< 0.6 x ØD1	1 x ØD1
P	Acier de décolletage au plomb		90	110	< 1.0 x ØD1	1 x ØD1
P	Acier fortement allié	700 – 1500 N/mm ²	40	55	< 0.3 x ØD1	1 x ØD1
M	Acier inoxydable	400 – 700 N/mm ²	70	90	< 0.8 x ØD1	1 x ØD1
K	Fonte grise / Fonte à graphite sphéroïdal perlitique	< 250 HB	90	110	< 0.7 x ØD1	1 x ØD1
K	Fonte alliée / Fonte à graphite sphéroïdal perlitique	> 250 HB	70	90	< 0.4 x ØD1	1 x ØD1
K	Fonte à graphite sphéroïdal ferritique / Fonte malléable		90	110	< 0.4 x ØD1	1 x ØD1
S	Titane, alliage de titane		40	60	< 0.3 x ØD1	1 x ØD1

DIXI 7593

CONDITIONS DE COUPE

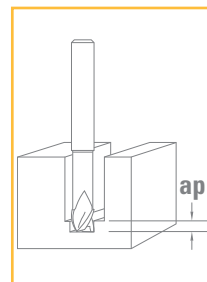

DIXI 7593 Z = 3-4

Aluminium

(Vc 400 - 600 m/min)

D ₁	Z	Vc [m/min]	n [min ⁻¹]	Vf [mm/min]	ap [mm]	ae [mm]	fz [mm]
6	3	400	21220	570	3	6	0.009
8	3	400	15920	570	4	8	0.012
10	3	400	12730	760	5	10	0.02
12	3	400	10610	760	6	12	0.024
16	3	400	7960	760	8	16	0.032
18	3	400	7070	760	9	18	0.036
20	4	400	6370	1020	10	20	0.04

$$n \text{ [tr/min]} = \frac{Vc \text{ [m/min]} \times 1000}{\pi \times D_1 \text{ [mm]}}$$

$$Vf \text{ [mm/min]} = n \text{ [tr/min]} \times fz \text{ [mm]} \times Z$$

Avance par dent **fz [mm]**

$\emptyset D_1$ 1.00 - 1.50	$\emptyset D_1$ 1.50 - 3.00	$\emptyset D_1$ 3.00 - 5.00	$\emptyset D_1$ 5.00 - 7.00	$\emptyset D_1$ 7.00 - 10.00	$\emptyset D_1$ 10.00 - 12.00
0.002 - 0.01	0.003 - 0.01	0.006 - 0.02	0.010 - 0.02	0.014 - 0.04	0.02 - 0.05
0.002 - 0.01	0.002 - 0.01	0.005 - 0.01	0.008 - 0.02	0.011 - 0.03	0.02 - 0.04
0.003 - 0.01	0.004 - 0.01	0.008 - 0.03	0.013 - 0.04	0.018 - 0.05	0.03 - 0.07
0.002 - 0.01	0.002 - 0.01	0.005 - 0.01	0.008 - 0.02	0.011 - 0.03	0.02 - 0.04
0.002 - 0.01	0.002 - 0.01	0.005 - 0.01	0.008 - 0.02	0.011 - 0.03	0.02 - 0.04
0.002 - 0.01	0.003 - 0.01	0.006 - 0.02	0.010 - 0.02	0.014 - 0.04	0.02 - 0.05
0.002 - 0.01	0.002 - 0.01	0.005 - 0.01	0.008 - 0.02	0.011 - 0.03	0.02 - 0.04
0.002 - 0.01	0.003 - 0.01	0.006 - 0.02	0.010 - 0.02	0.014 - 0.04	0.02 - 0.05
0.002 - 0.01	0.002 - 0.01	0.005 - 0.01	0.008 - 0.02	0.011 - 0.03	0.02 - 0.04



CONDITIONS DE COUPE

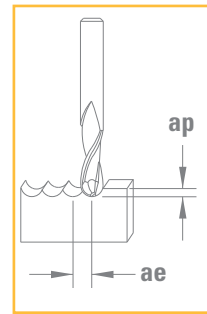

DIXI 7532 XIDUR Z = 2				Aciers à outils et fontes trempées		30-45 HRC (Vc 400 - 500 m/min)	
D	Vc [m/min]	n [min -1]	Vf [mm/min]	ap [mm]	ae [mm]	Deff. [mm]	fz [mm]
0.2 - 1		90000	1800	0.02	0.05	0.28	0.01
1.5	400	84890	3400	0.04	0.06	0.48	0.02
2	400	63660	3820	0.05	0.09	0.62	0.03
3	400	42440	3400	0.07	0.13	1.08	0.04
4	400	31830	3180	0.09	0.15	1.20	0.05
5	400	25470	3570	0.15	0.25	1.71	0.07
6	400	21220	3400	0.20	0.30	2.15	0.08
8	400	15920	3180	0.25	0.35	2.78	0.10
10	400	12730	3820	0.30	0.50	3.41	0.15

DIXI 7532 XIDUR Z = 2				Aciers à outils et fontes trempées		45 - 55 HRC (Vc 250 - 350 m/min)	
D	Vc [m/min]	n [min -1]	Vf [mm/min]	ap [mm]	ae [mm]	Deff. [mm]	fz [mm]
0.2 - 1	250	79580	1110	0.02	0.05	0.28	0.007
1.5	250	53050	2120	0.03	0.07	0.42	0.02
2	250	39790	2390	0.04	0.09	0.56	0.03
3	250	26530	2120	0.05	0.11	0.77	0.04
4	250	19890	1990	0.07	0.15	1.04	0.05
5	250	15920	1910	0.12	0.20	1.53	0.06
6	250	13260	1860	0.15	0.25	1.87	0.07
8	250	9950	1790	0.20	0.30	2.50	0.09
10	250	7960	1750	0.25	0.40	3.12	0.11

DIXI 7532 XIDUR Z = 2				Aciers à outils et fontes trempées		55 - 65 HRC (Vc 100 - 200 m/min)	
D	Vc [m/min]	n [min -1]	Vf [mm/min]	ap [mm]	ae [mm]	Deff. [mm]	fz [mm]
0.2 - 1	130	41380	330	0.02	0.04	0.28	0.004
1.5	130	27590	390	0.03	0.05	0.42	0.007
2	130	20690	410	0.04	0.06	0.56	0.010
3	130	13790	410	0.05	0.07	0.77	0.015
4	130	10350	520	0.06	0.10	0.97	0.025
5	130	8280	500	0.08	0.16	1.25	0.030
6	130	6900	550	0.10	0.18	1.54	0.040
8	130	5170	520	0.15	0.20	2.17	0.050
10	130	4140	500	0.18	0.22	2.65	0.060

Micropulvérisation recommandée, émulsion déconseillée

Les valeurs n et Vf sont indicatives et devront être ajustées en fonction de la longueur L₂ de l'outil

Les valeurs n et Vf sont un point de départ, en fonction de la qualité de l'empreinte à produire (précision et état de surface) elles pourront être augmentées ou diminuées.

Si la broche ne permet pas la rotation recommandée du tableau, l'avance Vf doit être réduite proportionnellement.

Usiner autant que possible en avalant.



CONDITIONS DE COUPE

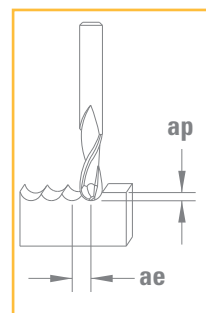

DIXI 7542 XIDUR Z = 2		Aciers à outils et fontes trempées			30-45 HRC		(Vc 400 - 500 m/min)	
D	Vc [m/min]	n [min ⁻¹]	Vf [mm/min]	ap [mm]	ae [mm]	Deff. [mm]	fz [mm]	
1		90000	1800	0.02	0.05	0.28	0.01	
1.5	320	67910	2720	0.04	0.06	0.48	0.02	
2	320	50930	3060	0.05	0.09	0.62	0.03	
3	320	33950	2720	0.07	0.13	1.08	0.04	
4	320	25470	2550	0.09	0.15	1.20	0.05	
5	320	20370	2850	0.15	0.25	1.71	0.07	
6	320	16980	2720	0.20	0.30	2.15	0.08	
8	320	12730	2550	0.25	0.35	2.78	0.10	
10	320	10190	3060	0.30	0.50	3.41	0.15	
12	320	8490	3400	0.40	0.60	4.31	0.20	

DIXI 7532 XIDUR Z = 2		Aciers à outils et fontes trempées			45 - 55 HRC		(Vc 250 - 350 m/min)	
D	Vc [m/min]	n [min ⁻¹]	Vf [mm/min]	ap [mm]	ae [mm]	Deff. [mm]	fz [mm]	
1	200	63660	890	0.02	0.05	0.28	0.007	
1.5	200	42440	1700	0.03	0.07	0.42	0.020	
2	200	31830	1910	0.04	0.09	0.56	0.030	
3	200	21220	1700	0.05	0.11	0.77	0.040	
4	200	15920	1590	0.07	0.15	1.04	0.050	
5	200	12730	1530	0.12	0.20	1.53	0.060	
6	200	10610	1490	0.15	0.25	1.87	0.070	
8	200	7960	1430	0.20	0.30	2.50	0.090	
10	200	6370	1400	0.25	0.40	3.12	0.110	
12	200	5310	1380	0.30	0.50	3.75	0.130	

DIXI 7532 XIDUR Z = 2		Aciers à outils et fontes trempées			55 - 65 HRC		(Vc 100 - 200 m/min)	
D	Vc [m/min]	n [min ⁻¹]	Vf [mm/min]	ap [mm]	ae [mm]	Deff. [mm]	fz [mm]	
1	100	31830	250	0.02	0.04	0.28	0.004	
1.5	100	21220	300	0.03	0.05	0.42	0.007	
2	100	15920	320	0.04	0.06	0.56	0.010	
3	100	10610	320	0.05	0.07	0.77	0.015	
4	100	7960	400	0.06	0.10	0.97	0.025	
5	100	6370	380	0.08	0.16	1.25	0.030	
6	100	5310	420	0.10	0.18	1.54	0.040	
8	100	3980	400	0.15	0.20	2.17	0.050	
10	100	3180	380	0.18	0.22	2.65	0.060	
12	100	2650	420	0.20	0.25	3.07	0.080	

Micropulvérisation recommandée, émulsion déconseillée

Les valeurs **n** et **Vf** sont un point de départ, en fonction de la qualité de l'empreinte à produire (précision et état de surface) elles pourront être augmentées ou diminuées.

Si la broche ne permet pas la rotation recommandée du tableau, l'avance **Vf** doit être réduite proportionnellement.

Usiner autant que possible en avalant.

CONDITIONS DE COUPE

DIXI 7520 XIDUR Z = 3-12		Aciers à outils et fontes trempées			45 - 55 HRC (Vc 30 - 70 m/min)		
D ₁	Z	Vc (m/min)	n (min -1)	Vf (mm/min)	ap (mm)	ae (mm)	fz (mm)
0.4 - 0.9	3	30	-	-	0.03 x D ₁	1 x D ₁	0.001 - 0.002
1	4	40	12800	125	0.04	1.00	0.002
1.5	4	40	8500	125	0.05	1.50	0.0035
2	5	40	6300	125	0.07	2.00	0.004
3	5	40	4240	150	0.12	3.00	0.007
4	5	40	3180	160	0.15	4.00	0.010
6	6	40	2120	190	0.20	6.00	0.015
8	6	40	1590	190	0.25	8.00	0.020
10	6	40	1270	190	0.30	10.00	0.025
12	8	40	1060	210	0.40	12.00	0.025
16	10	40	800	240	0.60	16.00	0.030

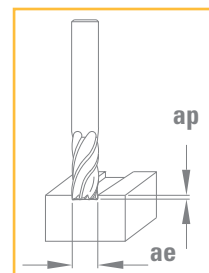

DIXI 7520 XIDUR Z = 3-12		Aciers à outils et fontes trempées			45 - 55 HRC (Vc 150 - 250 m/min)		
Ø	Z	Vc (m/min)	n (min -1)	Vf (mm/min)	ap (mm)	ae (mm)	fz (mm)
0.4 - 0.9	3	150	-	-	1 x D ₁	0.03 x D ₁	0.001 - 0.002
1	4	200	63700	640	1.00	0.04	0.002
1.5	4	200	42450	640	1.50	0.05	0.0035
2	5	200	32000	640	2.00	0.07	0.004
3	5	200	21300	750	3.00	0.12	0.007
4	5	200	15920	800	4.00	0.15	0.010
6	6	200	10610	950	6.00	0.20	0.015
8	6	200	7960	960	8.00	0.25	0.020
10	6	200	6370	960	10.00	0.30	0.025
12	8	200	5310	1060	12.00	0.40	0.025
16	10	200	3980	1190	16.00	0.60	0.030

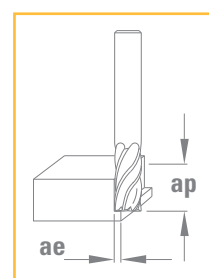

DIXI 7520 XIDUR Z = 3-12		Aciers à outils et fontes trempées			55 - 65 HRC (Vc 12 - 40 m/min)		
Ø	Z	Vc (m/min)	n (min -1)	Vf (mm/min)	ap (mm)	ae (mm)	fz (mm)
0.4 - 0.9	3	12	-	-	0.03 x D ₁	1 x D ₁	0.001 - 0.002
1	4	15	4700	45	0.03	1.00	0.002
1.5	4	15	3180	45	0.03	1.50	0.0035
2	5	15	2300	45	0.04	2.00	0.004
3	5	15	1600	55	0.05	3.00	0.007
4	5	15	1190	60	0.06	4.00	0.010
6	6	15	800	70	0.09	6.00	0.015
8	6	15	600	70	0.12	8.00	0.020
10	6	15	480	70	0.15	10.00	0.025
12	8	15	400	80	0.18	12.00	0.025
16	10	15	300	90	0.20	16.00	0.030

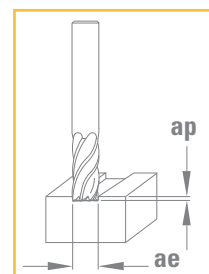

DIXI 7520 XIDUR Z = 3-12		Aciers à outils et fontes trempées			55 - 65 HRC (Vc 60 - 120 m/min)		
Z	Vc	n (m/min)	Vf (min -1)	ap (mm/min)	ae (mm)	fz (mm)	Ø (mm)
0.4 - 0.9	3	60	-	-	1 x D ₁	0.03 x D ₁	0.001 - 0.002
1	4	80	25500	250	1.00	0.03	0.002
1.5	4	80	17000	250	1.50	0.035	0.0035
2	5	80	12700	250	2.00	0.04	0.004
3	5	80	8500	290	3.00	0.05	0.007
4	5	80	6370	320	4.00	0.06	0.010
6	6	80	4240	380	6.00	0.09	0.015
8	6	80	3180	380	8.00	0.12	0.020
10	6	80	2550	380	10.00	0.15	0.025
12	8	80	2120	420	12.00	0.18	0.025
16	10	80	1590	480	16.00	0.20	0.030

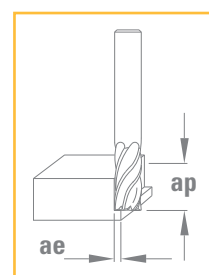

Micropulvérisation recommandée, émulsion déconseillée



CONDITIONS DE COUPE

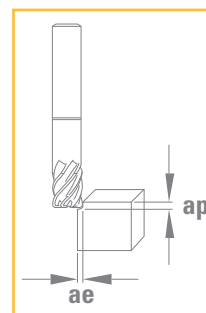

DIXI 7070 XIDUR Z = 4-6		Aciers à outils et fontes trempées			30-45 HRC	(Vc 150 - 200 m/min)	
D ₁	Z	Vc [m/min]	n [min ⁻¹]	Vf [mm/min]	ap [mm]	ae [mm]	fz [mm]
3	4	150	15900	3800	0.20	0.80	0.06
4	4	150	11940	4300	0.25	0.85	0.09
5	4	150	9550	4580	0.30	0.90	0.12
6	4	150	7960	4460	0.35	1.00	0.14
8	6	150	5970	5730	0.40	1.10	0.16
10	6	150	4770	5150	0.45	1.30	0.18
12	6	150	3980	4780	0.50	1.50	0.20

DIXI 7070 XIDUR Z = 4-6		Aciers à outils et fontes trempées			45 - 55 HRC	(Vc 130 - 170 m/min)	
D ₁	Z	Vc [m/min]	n [min ⁻¹]	Vf [mm/min]	ap [mm]	ae [mm]	fz [mm]
3	4	130	13700	2750	0.15	0.70	0.05
4	4	130	10350	3310	0.20	0.75	0.08
5	4	130	8280	3310	0.25	0.75	0.10
6	4	130	6900	3040	0.30	0.80	0.11
8	6	130	5170	3720	0.40	0.80	0.12
10	6	130	4140	3230	0.42	1.00	0.13
12	6	130	3450	2900	0.45	1.20	0.14

DIXI 7070 XIDUR Z = 4-6		Aciers à outils et fontes trempées			55 - 65 HRC	(Vc 100 - 130 m/min)	
D ₁	Z	Vc [m/min]	n [min ⁻¹]	Vf [mm/min]	ap [mm]	ae [mm]	fz [mm]
3	4	100	10600	500	0.08	0.20	0.010
4	4	100	7960	640	0.10	0.25	0.020
5	4	100	6370	890	0.12	0.28	0.035
6	4	100	5310	850	0.15	0.30	0.040
8	6	100	3980	1190	0.18	0.32	0.050
10	6	100	3180	1140	0.20	0.35	0.060
12	6	100	2650	1270	0.25	0.40	0.080





GRAVAGE



GRAVIEREN



ENGRAVING



INCISIONE



GRAVÍROZÁS

SÉLECTION DES FRAISES À GRAVER **222**



FRAISES À GRAVER 3/4 **225**



FRAISES À GRAVER 1/2 **228**



FRAISES À GRAVER HÉLICOÏDALES **230**



FRAISES À GRAVER EXÉCUTIONS SEMI-FINIES **231**



INFORMATIONS **233**









CONDITIONS DE COUPE **234**

SÉLECTION DES FRAISES À GRAVER

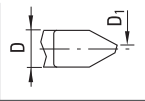



✓ = article de stock

EXÉCUTIONS TERMINÉES

FRAISES 3/4

		Page		<input type="checkbox"/> CARBURE	<input type="checkbox"/> DINAC	<input type="checkbox"/> DLC	
DIXI 7009		225	D = 3.00 D ₁ = 0.05-0.15	✓	✓		
DIXI 7001		225	D = 3.00 D ₁ = 0.05-0.20	✓	✓		
DIXI 7003		226	D = 3.00 R 0.05 - R 0.20	✓	✓		
DIXI 7002		226	D = 3.00 D ₁ = 0.05-0.20	✓	✓		
DIXI 7005		227	D = 3.00 D ₁ = 0.05-0.15	✓	✓		
DIXI 7006		227	D = 3.00 D ₁ = 0.05-0.15	✓	✓		

FRAISES 1/2

DIXI 7013		228	D = 3.00 D ₁ = 0.05-0.20	✓	✓	✓	
DIXI 7015		228	D = 3.00 D ₁ = 0.05-0.20	✓	✓		
DIXI 7017		229	D = 3.00-4.00 D ₁ = 0.05-0.20	✓	✓		
DIXI 7018		229	D = 3.00 D ₁ = 0.05-0.10	✓	✓		
DIXI 7019		230	D = 3.00 D ₁ = 0.05-0.10	✓	✓		

FRAISES HÉLICOÏDALES

DIXI 7025		230	D = 3.00-4.00 D ₁ = 0.10-0.15	✓			
------------------	---	-----	---	---	--	--	--



○ bien ⊙ excellent

Acier + Pb	Acier faibl. allié	Aciers fort. allié	Acier inox aust.	Aciers Fontes 45-65 HRC	Fontes	Super alliages Ni / Co	Titane, alliages de titane	Alliage Cu Argent Or	Alliage Cu difficile	Alu	Graphite	Plastique
------------	--------------------	--------------------	------------------	-------------------------	--------	------------------------	----------------------------	----------------------	----------------------	-----	----------	-----------

○	⊙	⊙	⊙		○	⊙	⊙	○	⊙	○	○	○
○	⊙	⊙	⊙	○	○	⊙	⊙	○	⊙	○	○	○
○	⊙	⊙	⊙	○	○	⊙	⊙	○	⊙	○	○	○
○	⊙	⊙	⊙	○	○	⊙	⊙	○	⊙	○	○	○
○	⊙	⊙	⊙	○	○	⊙	⊙	○	⊙	○	○	○
○	⊙	⊙	⊙	○	○	⊙	⊙	○	⊙	○	○	○





⊙	○	○	○		⊙	○	○	⊙	○	⊙	⊙	○
⊙	○	○	○		⊙	○	○	⊙	○	⊙	⊙	○
⊙	○	○	○		⊙	○	○	⊙	○	⊙	⊙	○
⊙	○	○	○		⊙	○	○	⊙	○	⊙	⊙	○
⊙	○	○	○		⊙	○	○	⊙	○	⊙	⊙	○

					⊙			⊙		⊙		
--	--	--	--	--	---	--	--	---	--	---	--	--

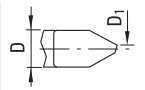

SÉLECTION DES FRAISES À GRAVER

✓ = article de stock

EXÉCUTIONS SEMI-FINIES		Page		<input type="checkbox"/> CARBURE			
DIXI 7012		231	D = 3.00-8.00 D ₁ = 1.00-2.60	✓			
DIXI 7016		231	D = 2.00-8.00	✓			
DIXI 7020		232	D = 2.00-10.00	✓			
DIXI 7024		232	D = 3.00-6.00	✓			



DIXI 7009

FRAISES À GRAVER 3/4, 30°
EXÉCUTION TERMINÉE

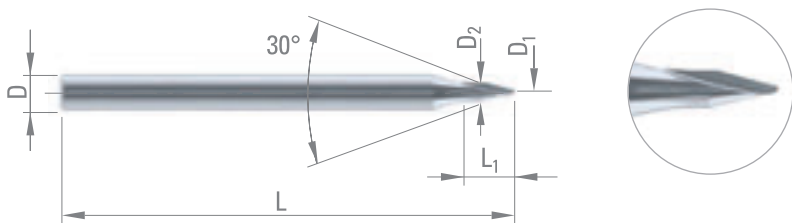

P. 234

Acier + Pb	Acier faibl. allié	Acier fort. allié	Acier inox aust.	Fontes
Super alliages Ni / Co	Titane, alliage de titane	Alliage Cu Argent Or	Alliage Cu difficile	Alu
Graphite	Plastique			

$D_{1\pm 0.01}$	L_1	D_2	D_{h5}	L	CARBURE	DINAC
0.05	3.4	1.5	3	38	976370	976374
0.08	3.4	1.5	3	38	976371	976375
0.10	3.4	1.5	3	38	976372	976376
0.15	3.4	1.5	3	38	976373	976377

DIXI 7001

FRAISES À GRAVER 3/4, 35°
EXÉCUTION TERMINÉE

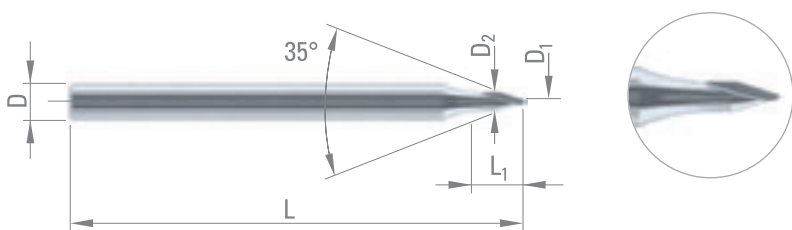

P. 234

Acier + Pb	Acier faibl. allié	Acier fort. allié	Acier inox aust.	Aciers Fontes 45-55 HRC
Fontes	Super alliages Ni / Co	Titane, alliage de titane	Alliage Cu Argent Or	Alliage Cu difficile
Alu	Graphite	Plastique		

$D_{1\pm 0.01}$	L_1	D_2	D_{h5}	L	CARBURE	DINAC
0.05	3.4	1.5	3	38	65846	959722
0.08	3.4	1.5	3	38	961244	961245
0.10	3.4	1.5	3	38	65848	959724
0.15	3.4	1.5	3	38	65850	959725
0.20	3.4	1.5	3	38	65852	959726



DIXI 7003

FRAISES À GRAVER 3/4, 35°
EXÉCUTION TERMINÉE

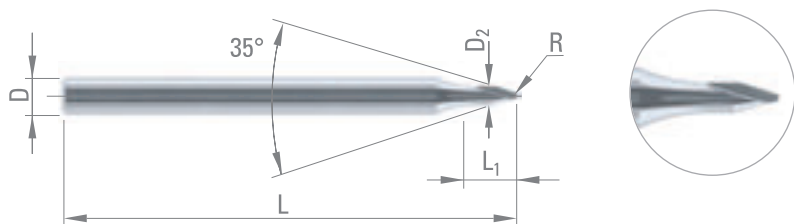

P. 234

Acier + Pb	Acier faibl. allié	Acier fort. allié	Acier inox aust.	Aciers Fontes 45-55 HRC
Fontes	Super alliages Ni / Co	Titane, alliage de titane	Alliage Cu Argent Or	Alliage Cu difficile
Alu	Graphite	Plastique		

$R_{\pm 0.01}$	L_1	D_2	D_{h5}	L	CARBURE	DINAC
0.05	3.4	1.5	3	38	51736	959718
0.10	3.4	1.5	3	38	51625	959719
0.15	3.4	1.5	3	38	51734	959720
0.20	3.4	1.5	3	38	51735	959721

DIXI 7002

FRAISES À GRAVER 3/4, 40°
EXÉCUTION TERMINÉE

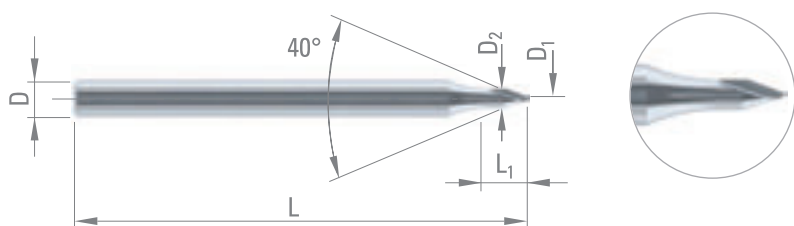

P. 234

Acier + Pb	Acier faibl. allié	Acier fort. allié	Acier inox aust.	Aciers Fontes 45-55 HRC
Fontes	Super alliages Ni / Co	Titane, alliage de titane	Alliage Cu Argent Or	Alliage Cu difficile
Alu	Graphite	Plastique		

$D_{1\pm 0.01}$	L_1	D_2	D_{h5}	L	CARBURE	DINAC
0.05	3.2	1.5	3	38	961225	961238
0.08	3.2	1.5	3	38	961242	961243
0.10	3.2	1.5	3	38	961226	961239
0.15	3.2	1.5	3	38	961227	961240
0.20	3.2	1.5	3	38	961228	961241

DIXI 7005

FRAISES À GRAVER 3/4, 50°
EXÉCUTION TERMINÉE

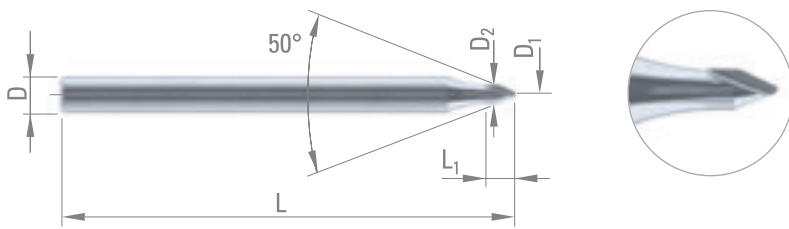

P. 235

Acier + Pb	Acier faibl. allié	Acier fort. allié	Acier inox aust.	Aciers Fontes 45-55 HRC
Fontes	Super alliages Ni / Co	Titane, alliage de titane	Alliage Cu Argent Or	Alliage Cu difficile
Alu	Graphite	Plastique		

$D_{1\pm 0.01}$	L_1	D_2	D_{h5}	L	CARBURE	DINAC
0.05	2.3	1.5	3	38	976258	976264
0.08	2.3	1.5	3	38	976260	976265
0.10	2.3	1.5	3	38	976261	976266
0.15	2.3	1.5	3	38	976263	976267

DIXI 7006

FRAISES À GRAVER 3/4, 60°
EXÉCUTION TERMINÉE

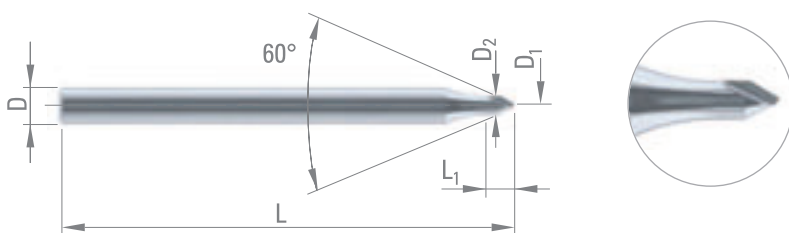

P. 235

Acier + Pb	Acier faibl. allié	Acier fort. allié	Acier inox aust.	Aciers Fontes 45-55 HRC
Fontes	Super alliages Ni / Co	Titane, alliage de titane	Alliage Cu Argent Or	Alliage Cu difficile
Alu	Graphite	Plastique		

$D_{1\pm 0.01}$	L_1	D_2	D_{h5}	L	CARBURE	DINAC
0.05	2.3	1.5	3	38	976361	976365
0.08	2.3	1.5	3	38	976362	976366
0.10	2.3	1.5	3	38	976363	976367
0.15	2.3	1.5	3	38	976364	976368

DIXI 7013

FRAISES À GRAVER 1/2, 30°
EXÉCUTION TERMINÉE

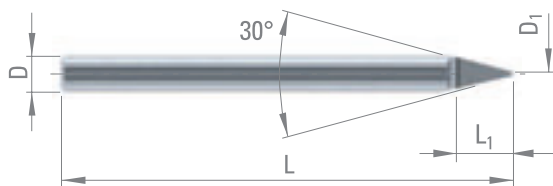

P. 234

Acier + Pb	Acier faibl. allié	Acier fort. allié	Acier inox aust.	Fontes
Super alliages Ni / Co	Titane, alliage de titane	Alliage Cu Argent Or	Alliage Cu difficile	Alu
Graphite	Plastique			

$D_{1\pm 0.01}$	L_1	D_{h5}	L	CARBURE	DINAC	DLC
0.05	4	3	38	961336	962814	961337
0.10	4	3	38	961338	962813	961339
0.15	4	3	38	961340	962812	961342
0.20	4	3	38	961341	962116	961343

DIXI 7015

FRAISES À GRAVER 1/2, 50°
EXÉCUTION TERMINÉE

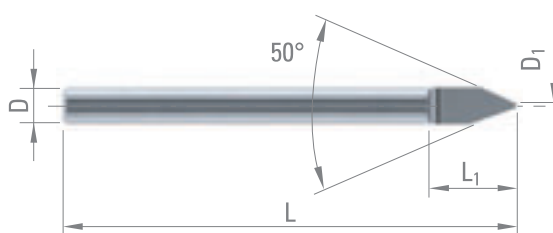

P. 235

Acier + Pb	Acier faibl. allié	Acier fort. allié	Acier inox aust.	Fontes
Super alliages Ni / Co	Titane, alliage de titane	Alliage Cu Argent Or	Alliage Cu difficile	Alu
Graphite	Plastique			

$D_{1\pm 0.01}$	L_1	D_{h5}	L	CARBURE	DINAC
0.05	6	3	38	961326	961327
0.08	6	3	38	961328	961333
0.10	6	3	38	961329	961332
0.15	6	3	38	961330	961334
0.20	6	3	38	961331	961335



DIXI 7017

FRAISES À GRAVER 1/2, 60°
EXÉCUTION TERMINÉE

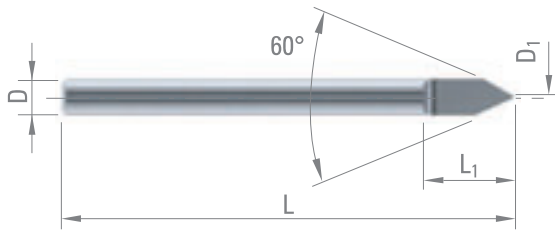

P. 235

Acier + Pb	Acier faibl. allié	Acier fort. allié	Acier inox aust.	Fontes
Super alliages Ni / Co	Titane, alliage de titane	Alliage Cu Argent Or	Alliage Cu difficile	Alu
Graphite	Plastique			

$D_{1\pm 0.01}$	L_1	D_{h5}	L	CARBURE	DINAC
0.05	6	3	38	43536	959712
	8	4	50	43537	959714
0.08	6	3	38	972400	972401
0.10	6	3	38	40939	959713
	8	4	50	45813	959716
0.15	6	3	38	953721	960610
0.20	6	3	38	954292	960611
	8	4	50	45814	959717

DIXI 7018

FRAISES À GRAVER 1/2, 90°
EXÉCUTION TERMINÉE

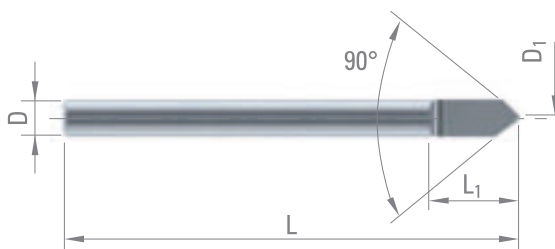

P. 235

Acier + Pb	Acier faibl. allié	Acier fort. allié	Acier inox aust.	Fontes
Super alliages Ni / Co	Titane, alliage de titane	Alliage Cu Argent Or	Alliage Cu difficile	Alu
Graphite	Plastique			

$D_{1\pm 0.01}$	L_1	D_{h5}	L	CARBURE	DINAC
0.05	6	3	38	961246	961248
0.10	6	3	38	961247	961249

DIXI 7019

FRAISES À GRAVER 1/2, 120°
EXÉCUTION TERMINÉE

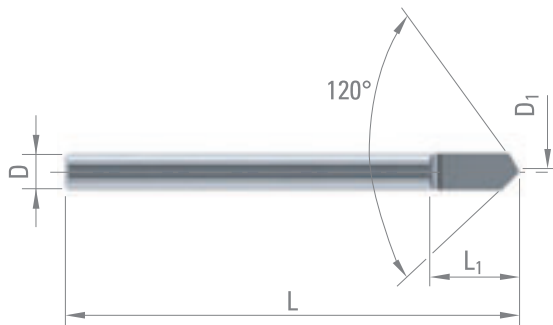

P. 235

Acier + Pb	Acier faibl. allié	Acier fort. allié	Acier inox aust.	Fontes
Super alliages Ni / Co	Titane, alliage de titane	Alliage Cu Argent Or	Alliage Cu difficile	Alu
Graphite	Plastique			

$D_{1\pm 0.01}$	L_1	D_{h5}	L	CARBURE	DINAC
0.05	6	3	38	961322	961323
0.10	6	3	38	961324	961325

DIXI 7025

FRAISES À GRAVER HÉLICOÏDALES 60°
EXÉCUTION TERMINÉE

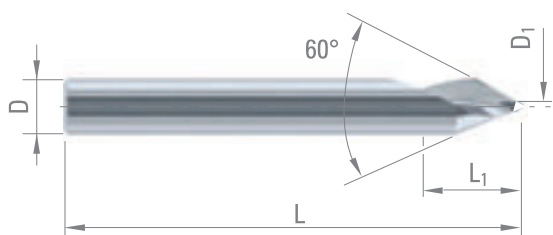

P. 235

Fontes	Alliage Cu Argent Or	Alu
--------	----------------------	-----

$D_{1\pm 0.02}$	L_1	D_{h5}	L	CARBURE
0.10	9	3	38	43624
0.15	12	4	50	45812

DIXI 7012

FRAISES À GRAVER 30°
EXÉCUTION SEMI-FINIE



P. 233

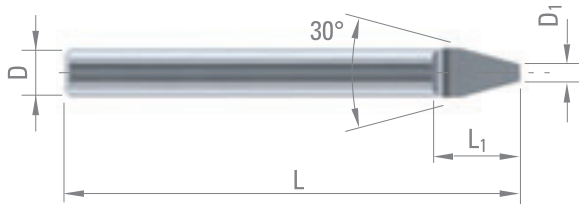

D_1	L_1	D_{h5}	L	CARBURE
1.00	4	3	38	35505
1.30	5	4	50	35666
2.00	8	6	57	35506
2.60	10	8	63	35668

DIXI 7016

FRAISES À GRAVER 60°
EXÉCUTION SEMI-FINIE



P. 233

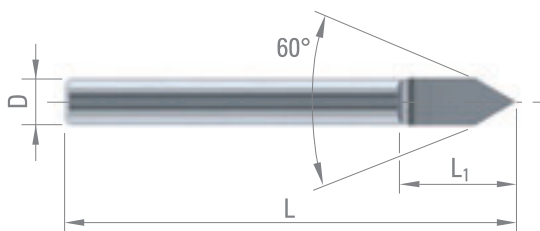

D_{h5}	L_1	L	CARBURE
2	4	25	32852
3	6	38	23585
4	8	50	23586
5	10	50	35082
6	12	57	29726
8	14	63	29727



DIXI 7020

FRAISES À GRAVER 180°
EXÉCUTION SEMI-FINIE



P. 233

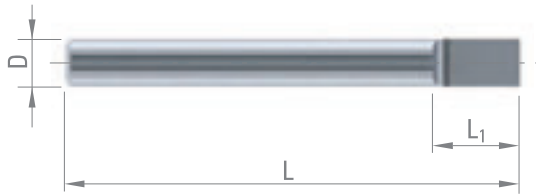

D_{h5}	L_1	L	CARBURE
2	3	25	35671
3	4	38	35672
4	5	50	35673
5	6	50	35674
6	8	57	35675
8	10	63	35676
10	12	72	35677

DIXI 7024

FRAISES À GRAVER HÉLICOÏDALES 60°
EXÉCUTION SEMI-FINIE



P. 233

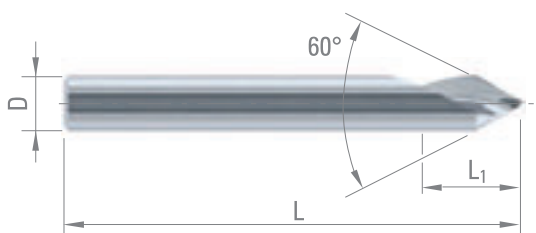

D_{h5}	L_1	L	CARBURE
3	9	38	35678
4	12	50	35679
6	15	50	35680



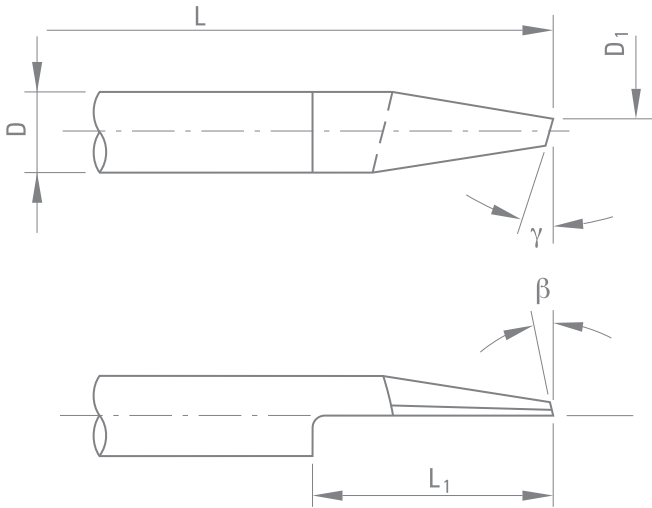

Utilisées essentiellement pour le gravage de symboles et textes divers, ces fraises servent également à l'usinage de contours (découpage de formes) ainsi que pour des travaux de copiage pour moules et étampes.

EXÉCUTION TERMINÉE

Sur demande, DIXI POLYTOOL livre ces outils affûtés en fonction des matières à usiner qu'il conviendra de préciser lors de la commande.

Les angles d'affûtage correspondront au tableau ci-contre.

Indiquez D_1 ainsi que la matière à usiner lors de la commande.

Matériaux	β	γ
Aciers à outils	10°	3° - 5°
Aciers	15°	3° - 5°
Inox	15°	3° - 5°
Fontes	15°	3° - 5°
Cuivre	20°	3° - 5°
Laiton	15°	3° - 5°
Maillechort	15°	3° - 5°
Duralumin	20°	3° - 5°
Aluminium	20°	3° - 5°
Or	15°	3° - 5°
Titane pur	15°	3° - 5°
Celluloïde	25°	3° - 5°
Plastiques	20°	3° - 5°
Bois	25°	3° - 5°



CONDITIONS DE COUPE

Matières à usiner

			CARBURE		DINAC		Ø D ₁ 0.05 - 0.10		Ø D ₁ 0.15 - 0.50	
			n [tr/min]	n [tr/min]	Vf[mm/min]	ap[mm]	Vf[mm/min]	ap[mm]		
P	Acier non allié / faiblement allié	< 600 N/mm ²	20 - 35'000	20 - 35'000	50 - 250	0.05 - 0.30	100 - 300	0.10 - 0.40		
P	Acier non allié / faiblement allié	600 – 1500 N/mm ²		20 - 35'000	50 - 200	0.05 - 0.25	80 - 250	0.10 - 0.35		
P	Acier de décolletage au plomb			20 - 35'000	50 - 250	0.05 - 0.30	100 - 300	0.10 - 0.40		
P	Acier fortement allié	700 – 1500 N/mm ²		20 - 35'000	50 - 150	0.05 - 0.15	80 - 250	0.10 - 0.30		
M	Acier inoxydable	400 – 700 N/mm ²		20 - 35'000	50 - 150	0.05 - 0.20	80 - 250	0.10 - 0.30		
M	Acier inox. DUPLEX, acier austénitique inox. sans nickel	> 800 N/mm ²		20 - 35'000	50 - 150	0.05 - 0.15	80 - 250	0.10 - 0.30		
H	Acier à outils et fontes trempées	> 1500 N/mm ² (45 - 55 HRC)		20 - 35'000			80 - 250	0.02 - 0.05		
K	Fonte grise / Fonte à graphite sphéroïdal perlitique	< 250 HB	20 - 35'000	20 - 35'000	50 - 250	0.05 - 0.30	100 - 300	0.10 - 0.40		
K	Fonte allié / Fonte à graphite sphéroïdal perlitique	> 250 HB	20 - 35'000	20 - 35'000	50 - 200	0.05 - 0.25	80 - 250	0.10 - 0.35		
K	Fonte à graphite sphéroïdal ferritique / Fonte malléable		20 - 35'000	20 - 35'000	50 - 200	0.05 - 0.25	80 - 250	0.10 - 0.35		
S	Super alliages / Acier inox. réfractaire	Inconel Nimonic Hastelloy		15 - 25'000			80 - 200	0.03 - 0.10		
S	Titane, alliage de titane		20 - 35'000	20 - 35'000	50 - 200	0.05 - 0.25	100 - 250	0.10 - 0.35		
N	Alliage de cuivre / bonne usinabilité (laiton – bronze)		20 - 35'000	20 - 35'000	50 - 300	0.05 - 0.30	150 - 450	0.10 - 0.40		
N	Alliage de cuivre / usinabilité difficile / Bronze à l'aluminium (Ampco)	(CuAlFe)	20 - 35'000	20 - 35'000	50 - 200	0.05 - 0.30	100 - 300	0.10 - 0.45		
N	Alliage d'aluminium	Si < 8%	20 - 35'000	20 - 35'000	50 - 300	0.05 - 0.30	150 - 450	0.10 - 0.45		
N	Fonte d'aluminium	Si > 8%	20 - 35'000	20 - 35'000	50 - 300	0.05 - 0.30	150 - 450	0.10 - 0.45		
N	Graphite		20 - 35'000	20 - 35'000	50 - 300	0.05 - 0.30	150 - 450	0.10 - 0.45		
N	Plastique		20 - 35'000	20 - 35'000	50 - 300	0.05 - 0.30	150 - 450	0.10 - 0.45		
N	Or, argent		20 - 35'000	20 - 35'000	50 - 300	0.05 - 0.30	150 - 450	0.10 - 0.45		



CONDITIONS DE COUPE

Matières à usiner			CARBURE	DINAC	Ø D ₁ 0.05 - 0.10		Ø D ₁ 0.15 - 0.50	
			n [tr/min]	n [tr/min]	Vf[mm/min]	ap[mm]	Vf[mm/min]	ap[mm]
P	Acier non allié / faiblement allié	< 600 N/mm ²	25 - 35'000		75 - 250	0.05 - 0.35	100 - 350	0.10 - 0.45
P	Acier non allié / faiblement allié	600 – 1500 N/mm ²		25 - 35'000	60 - 250	0.05 - 0.30	80 - 300	0.10 - 0.40
P	Acier de décolletage au plomb		30 - 35'000		75 - 250	0.05 - 0.35	100 - 350	0.10 - 0.45
P	Acier fortement allié	700 – 1500 N/mm ²		15 - 35'000	50 - 200	0.05 - 0.10	80 - 300	0.10 - 0.35
M	Acier inoxydable	400 – 700 N/mm ²		20 - 35'000	50 - 200	0.05 - 0.25	80 - 300	0.10 - 0.35
M	Acier inox. DUPLEX, acier austénitique inox. sans nickel	> 800 N/mm ²		15 - 35'000	50 - 200	0.05 - 0.20	80 - 300	0.10 - 0.35
H	Acier à outils et fontes trempées	> 1500 N/mm ² (45 - 55 HRC)		20 - 35'000			80 - 250	0.02 - 0.07
K	Fonte grise / Fonte à graphite sphéroïdal perlitique	< 250 HB	25 - 35'000		50 - 300	0.05 - 0.35	100 - 350	0.10 - 0.45
K	Fonte allié / Fonte à graphite sphéroïdal perlitique	> 250 HB	15 - 35'000	15 - 35'000	50 - 250	0.05 - 0.30	80 - 300	0.10 - 0.40
K	Fonte à graphite sphéroïdal ferritique / Fonte malléable		15 - 35'000	15 - 35'000	50 - 250	0.05 - 0.30	80 - 300	0.10 - 0.40
S	Super alliages / Acier inox. réfractaire	Inconel Nimonic Hastelloy		10 - 15'000			80 - 250	0.05 - 0.10
S	Titane, alliage de titane		20 - 35'000		75 - 200	0.05 - 0.20	100 - 300	0.10 - 0.40
N	Alliage de cuivre / bonne usinabilité (laiton – bronze)		30 - 35'000		75 - 300	0.05 - 0.20	150 - 450	0.20 - 0.30
N	Alliage de cuivre / usinabilité difficile / Bronze à l'aluminium	(CuAlFe) (Ampco)	20 - 35'000		75 - 350	0.05 - 0.15	150 - 300	0.10 - 0.20
N	Alliage d'aluminium	Si < 8%	25 - 35'000		75 - 300	0.05 - 0.30	150 - 450	0.15 - 0.50
N	Fonte d'aluminium	Si > 8%	20 - 35'000		75 - 350	0.05 - 0.20	150 - 450	0.15 - 0.45
N	Graphite		20 - 35'000		75 - 350	0.05 - 0.20	150 - 450	0.15 - 0.40
N	Plastique		30 - 35'000		100 - 350	0.05 - 0.30	180 - 450	0.15 - 0.50
N	Or, argent		25 - 35'000		75 - 350	0.05 - 0.20	150 - 450	0.15 - 0.40





TRONÇONNAGE

ABTRENNEN

SLITTING

TRONCATURA

DARABOLÁS

SÉLECTION DES FRAISES À FENDRE **238**



FRAISES À FENDRE **242**



TASSEaux PORTE-FRAISES **257**



FRAISES À T **259**



FRAISES-MÈRES **262**



















OUTILS SUR DEMANDE **266**





CONDITIONS DE COUPE **270**

SÉLECTION DES FRAISES À FENDRE



✓ = article de stock

FRAISES À FENDRE		Page		<input type="checkbox"/> CARBURE	<input type="checkbox"/> CUTINOX				
DIXI 1531 Ø 15 - 125		242	 	✓					
DIXI 1533 Ø 15 - 160		245	 	✓					
DIXI 1539 Ø 10 - 50		249		✓					
DIXI 1534 Ø 20 - 100		253	 	✓					
DIXI 1537 Ø 50 - 100		255	 		✓				
DIXI 1640 Ø 50 - 100		256		✓					

TASSEaux PORTE-FRAISES

DIXI 2713 Ø 3 - 16		257							
DIXI 2714 Ø 5 - 16		258							

FRAISES À T

DIXI 1525 Ø 2 - 30		259		✓	✓				
DIXI 1528 Ø 4 - 30		260		✓	✓				
DIXI 1527 Ø 4 - 16		261		✓	✓				



○ bien ⊙ excellent

Acier + Pb	Acier faibl. allié	Aciers fort. allié	Acier inox aust.	Aciers Fontes 45-65 HRC	Fontes	Super alliages Ni / Co	Titane, alliages de titane	Alliage Cu Argent Or	Alliage Cu difficile	Alu	Graphite	Plastique
------------	--------------------	--------------------	------------------	-------------------------	--------	------------------------	----------------------------	----------------------	----------------------	-----	----------	-----------







⊙	⊙	⊙	○		⊙	⊙	⊙	○	○	○		○
○	○	○	○		⊙	○	○	○	○	○		○
○	○	○	○		⊙	○	○	○	○			
○	○	○	⊙		○	○	○	⊙	⊙	⊙		⊙
○	○	⊙	⊙			⊙	⊙	○	○	○		○
○	○	○	○		⊙	○	○	⊙	○	○		○

⊙	⊙	○	○		⊙	○	○	⊙	○	⊙		○
⊙	⊙	○	○		⊙	○	○	⊙	○	⊙		○
⊙	⊙	○	○		⊙	○	○	⊙	○	⊙		○



SÉLECTION DES FRAISES-MÈRES

✓ = article de stock

FRAISES-MÈRES		Page	☐ CARBURE					
DIXI 1675 Ø 6 - 24		262	✓					
DIXI 1680 Ø 6 - 24		262	✓					
DIXI 1685 Ø 6 - 24		263	✓					
DIXI 1690 Ø 10 - 12		264	✓					
DIXI 1674 Ø 6 - 24		265	✓					



○ bien ⊙ excellent

Acier + Pb	Acier faibl. allié	Aciers fort. allié	Acier inox aust.	Aciers Fontes 45-65 HRC	Fontes	Super alliages Ni / Co	Titane, alliages de titane	Alliage Cu Argent Or	Alliage Cu difficile	Alu	Graphite	Plastique
⊙	⊙	○	○				○	⊙	○	⊙		
⊙	⊙	○	○				○	⊙	○	⊙		
⊙	⊙	○	○				○	⊙	○	⊙		
⊙	⊙	○	○				○	⊙	○	⊙		
⊙	⊙	○	○				○	⊙	○	⊙		



DIXI 1531

FRAISES À FENDRE DENTURE LARGE

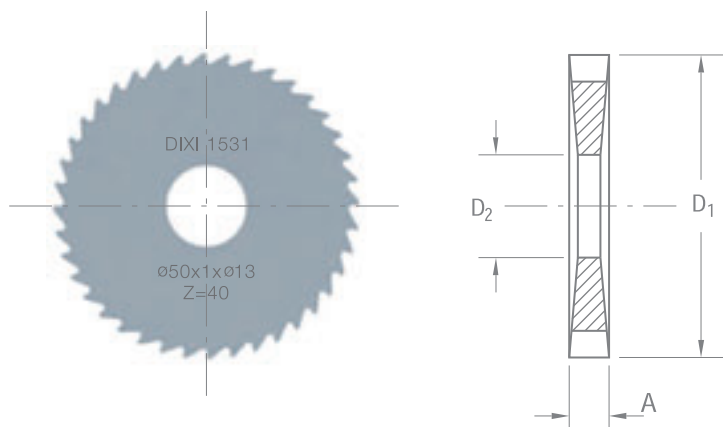

P. 270



Acier + Pb	Acier faibl. allié	Acier fort. allié	Acier inox aust.	Fontes
Super alliages Ni / Co	Titane, alliage de titane	Alliage Cu Argent Or	Alliage Cu difficile	Alu
Plastique				

D ₁ js12	A ±0.01	D ₂ H6	Z	CARBURE
15	0.20	5	32	37180
15	0.30	5	24	37182
15	0.40	5	24	35382
15	0.50	5	24	35383
15	0.60	5	20	601
15	0.70	5	20	603
15	0.80	5	20	2532
15	0.90	5	20	7707
15	1.00	5	20	602
15	1.20	5	16	38947
15	1.50	5	16	38948
15	1.60	5	16	42457
15	1.80	5	16	42536
15	2.00	5	16	38949
20	0.20	5	40	35384
20	0.30	5	32	35385
20	0.40	5	32	3281
20	0.50	5	24	31481
20	0.60	5	24	604
20	0.70	5	24	605
20	0.80	5	24	37080
20	0.90	5	24	3282
20	1.00	5	20	3283
20	1.20	5	20	2425
20	1.50	5	20	3287
20	1.60	5	20	3288
20	1.80	5	20	3290
20	2.00	5	16	42458
20	2.50	5	16	42459
25	0.30	8	40	37740
25	0.40	8	32	42461
25	0.50	8	32	42376
25	0.60	8	32	42377
25	0.70	8	32	42378
25	0.80	8	24	2479
25	1.00	8	24	42380
25	1.20	8	24	42462



DIXI 1531

D_{1js12}	$A_{\pm 0.01}$	D_{2H6}	Z	CARBURE
25	1.50	8	20	3299
25	1.60	8	20	3300
25	2.00	8	20	3303
30	0.30	8	40	37845
30	0.40	8	40	37841
30	0.50	8	40	35386
30	0.60	8	32	30662
30	0.70	8	32	3309
30	0.80	8	32	41350
30	0.90	8	32	41351
30	1.00	8	32	36413
30	1.20	8	24	1327
30	1.50	8	24	3316
30	1.60	8	24	3317
30	1.80	8	24	3319
30	2.00	8	24	3321
30	2.50	8	20	42466
30	3.00	8	20	42467
30	4.00	8	20	42468
40	0.40	10	48	42470
40	0.50	10	40	2662
40	0.60	10	40	6348
40	0.70	10	40	17953
40	0.80	10	40	42471
40	0.90	10	40	38817
40	1.00	10	32	3034
40	1.20	10	32	3307
40	1.50	10	32	3326
40	1.60	10	32	3798
40	1.80	10	32	39499
40	2.00	10	24	42472
40	2.50	10	24	42473
40	3.00	10	24	42474
40	4.00	10	20	42475
50	0.40	13	48	26023
50	0.50	13	48	42477
50	0.60	13	48	42478
50	0.70	13	48	14681
50	0.80	13	40	3330
50	0.90	13	40	41064
50	1.00	13	40	8636
50	1.20	13	40	8637
50	1.40	13	40	3336
50	1.50	13	32	25731
50	1.60	13	32	3337
50	1.80	13	32	3657
50	2.00	13	32	2533
50	2.50	13	32	3339
50	3.00	13	24	42479



P. 270



Acier + Pb	Acier faibl. allié	Acier fort. allié	Acier inox aust.	Fontes
Super alliages Ni / Co	Titane, alliage de titane	Alliage Cu Argent Or	Alliage Cu difficile	Alu
Plastique				

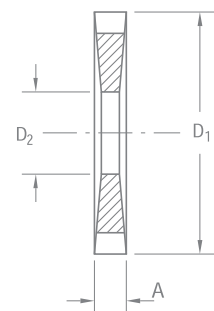
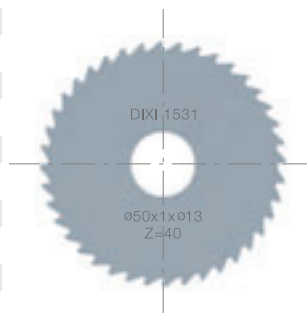

DIXI 1531

D_{1js12}	$A_{\pm 0.01}$	D_{2H6}	Z	CARBURE
63	0.80	16	48	3342
63	1.00	16	48	609
63	1.20	16	40	3658
63	1.50	16	40	3345
63	1.60	16	40	3346
63	1.80	16	40	3347
63	2.00	16	40	610
63	2.50	16	32	42483
63	3.00	16	32	611
80	0.80	22	64	6070
80	1.00	22	48	3054
80	1.20	22	48	4016
80	1.50	22	48	3349
80	1.60	22	48	34808
80	1.80	22	48	22178
80	2.00	22	40	2807
80	2.50	22	40	42484
80	3.00	22	40	21847
100	1.00	22	64	38542
100	1.20	22	64	38543
100	1.50	22	48	35387
100	1.60	22	48	39146
100	1.80	22	48	38927
100	2.00	22	48	38928
125	1.00	22	80	42489
125	1.20	22	64	42490
125	1.50	22	64	38480
125	2.00	22	64	39005



P. 270



Acier + Pb

Acier faibl. allié

Acier fort. allié

Acier inox aust.

Fontes

Super alliages Ni / Co

Titane, alliage de titane

Alliage Cu Argent Or

Alliage Cu difficile

Alu

Plastique

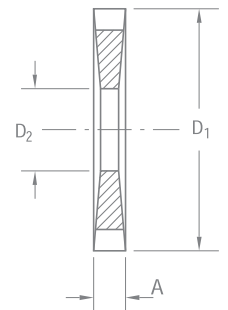
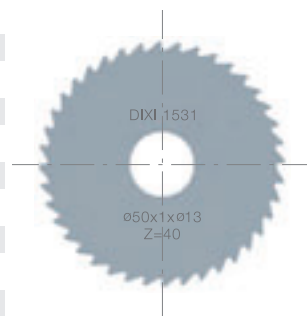

DIXI 1533

FRAISES À FENDRE DENTURE FINE

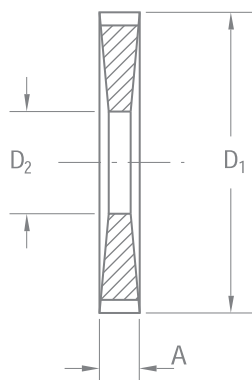
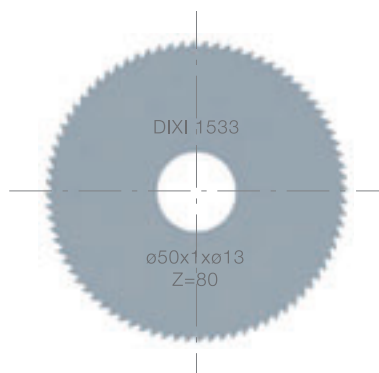

P. 270



Acier + Pb	Acier faibl. allié	Acier fort. allié	Acier inox aust.	Fontes
Super alliages Ni / Co	Titane, alliage de titane	Alliage Cu Argent Or	Alliage Cu difficile	Alu
Plastique				

D_1 js12	A ±0.01	D_2 H6	Z	CARBURE
15	0.20	5	64	36382
15	0.25	5	64	35635
15	0.30	5	48	3707
15	0.40	5	48	3708
15	0.50	5	48	613
15	0.60	5	40	5453
15	0.70	5	40	6183
15	0.80	5	40	3244
15	0.90	5	40	3245
15	1.00	5	40	614
15	1.10	5	32	43250
15	1.20	5	32	37174
15	1.50	5	32	40710
15	1.60	5	32	40711
15	1.70	5	32	40712
15	1.80	5	32	40713
15	2.00	5	32	37175
20	0.20	5	80	617
20	0.25	5	64	618
20	0.30	5	64	34590
20	0.40	5	64	1659
20	0.50	5	48	18560
20	0.60	5	48	36647
20	0.70	5	48	39659
20	0.80	5	48	627
20	0.90	5	48	623
20	1.00	5	40	35565
20	1.10	5	40	2689
20	1.20	5	40	38141
20	1.30	5	40	3407
20	1.40	5	40	3408
20	1.50	5	40	624
20	1.60	5	40	3010
20	1.80	5	40	23600
20	2.00	5	32	625
20	2.50	5	32	36690
20	3.00	5	32	626



DIXI 1533

D_{1js12}	$A_{\pm 0.01}$	D_{2H6}	Z	CARBURE
25	0.20	8	80	1660
25	0.25	8	80	3249
25	0.30	8	80	2421
25	0.35	8	80	1688
25	0.40	8	64	37661
25	0.50	8	64	14254
25	0.60	8	64	630
25	0.70	8	64	36365
25	0.80	8	48	632
25	0.90	8	48	633
25	1.00	8	48	634
25	1.10	8	48	2422
25	1.20	8	48	3250
25	1.30	8	48	3410
25	1.40	8	48	3412
25	1.50	8	40	35450
25	1.80	8	40	3414
25	2.00	8	40	636
25	2.50	8	40	637
25	3.00	8	32	38971
25	4.00	8	32	3728

30	0.20	8	100	14689
30	0.25	8	100	4262
30	0.30	8	80	638
30	0.40	8	80	639
30	0.50	8	80	18429
30	0.60	8	64	18375
30	0.70	8	64	37731
30	0.80	8	64	35516
30	0.90	8	64	36052
30	1.00	8	64	2376
30	1.10	8	48	35420
30	1.20	8	48	36384
30	1.30	8	48	3417
30	1.40	8	48	2424
30	1.50	8	48	2924
30	1.60	8	48	3418
30	1.70	8	48	5948
30	1.80	8	48	6362
30	2.00	8	48	645
30	2.50	8	40	6361
30	3.00	8	40	3419
30	4.00	8	40	33482
30	5.00	8	32	35095

40	0.20	10	128	24084
40	0.25	10	100	22049
40	0.30	10	100	35370
40	0.40	10	100	4690
40	0.50	10	80	648
40	0.60	10	80	677
40	0.70	10	80	649
40	0.80	10	80	35444
40	0.90	10	80	35369
40	1.00	10	64	653
40	1.10	10	64	3253



P. 270



Acier + Pb	Acier faibl. allié	Acier fort. allié	Acier inox aust.	Fontes
Super alliages Ni / Co	Titane, alliage de titane	Alliage Cu Argent Or	Alliage Cu difficile	Alu
Plastique				

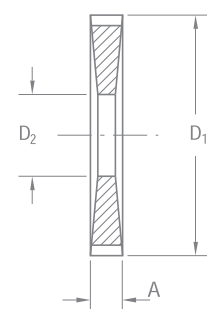
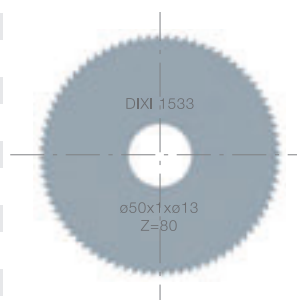

DIXI 1533

D_{1js12}	$A_{\pm 0.01}$	D_{2H6}	Z	CARBURE
40	1.20	10	64	36049
40	1.30	10	64	43352
40	1.40	10	64	3422
40	1.50	10	64	36050
40	1.60	10	64	36051
40	1.70	10	64	6170
40	1.80	10	64	3424
40	2.00	10	48	656
40	2.50	10	48	36648
40	3.00	10	48	658
40	4.00	10	40	3737
40	5.00	10	40	35097
50	0.20	13	128	36385
50	0.25	13	128	3426
50	0.30	13	128	659
50	0.40	13	100	35234
50	0.50	13	100	31880
50	0.60	13	100	3030
50	0.70	13	100	2957
50	0.80	13	80	661
50	0.90	13	80	3255
50	1.00	13	80	662
50	1.10	13	80	1663
50	1.20	13	80	2536
50	1.30	13	80	3429
50	1.40	13	80	43114
50	1.50	13	64	37517
50	1.60	13	64	663
50	1.70	13	64	8001
50	1.80	13	64	36336
50	2.00	13	64	37806
50	2.50	13	64	37732
50	3.00	13	48	35636
50	4.00	13	48	667
50	5.00	13	48	35109
63	0.30	16	128	5398
63	0.40	16	128	669
63	0.50	16	128	2969
63	0.60	16	100	2634
63	0.70	16	100	3207
63	0.80	16	100	36739
63	1.00	16	100	671
63	1.20	16	80	35233
63	1.40	16	80	5093
63	1.50	16	80	2774
63	1.60	16	80	676
63	1.70	16	80	3432
63	1.80	16	80	3433
63	2.00	16	80	672
63	2.50	16	64	673
63	3.00	16	64	674
63	4.00	16	64	3748
63	5.00	16	48	31882



P. 270



Acier + Pb	Acier faibl. allié	Acier fort. allié	Acier inox aust.	Fontes
Super alliages Ni / Co	Titane, alliage de titane	Alliage Cu Argent Or	Alliage Cu difficile	Alu
Plastique				

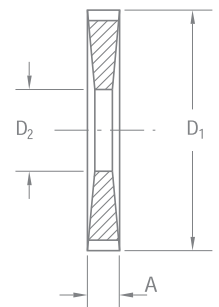
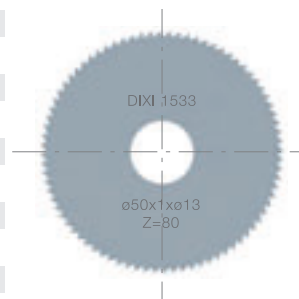

DIXI 1533

D_{1js12}	$A_{\pm 0.01}$	D_{2H6}	Z	CARBURE
80	0.80	22	128	35817
80	1.00	22	100	679
80	1.20	22	100	680
80	1.40	22	100	3534
80	1.50	22	100	35721
80	1.60	22	100	19241
80	1.80	22	100	14115
80	2.00	22	80	17745
80	2.50	22	80	4030
80	3.00	22	80	684
80	4.00	22	64	21256
100	0.80	22	128	685
100	1.00	22	128	35816
100	1.20	22	128	38383
100	1.50	22	100	36363
100	1.60	22	100	3438
100	2.00	22	100	36048
100	2.50	22	100	689
100	3.00	22	80	36364
100	4.00	22	80	35138
100	5.00	22	80	35136
125	1.00	22	160	30687
125	1.20	22	128	35141
125	1.50	22	128	34954
125	2.00	22	128	34827
125	3.00	22	100	35294
160	1.20	32	160	34523
160	1.50	32	160	35299



P. 270



Acier + Pb	Acier faibl. allié	Acier fort. allié	Acier inox aust.	Fontes
Super alliages Ni / Co	Titane, alliage de titane	Alliage Cu Argent Or	Alliage Cu difficile	Alu
Plastique				

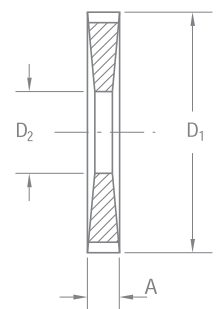
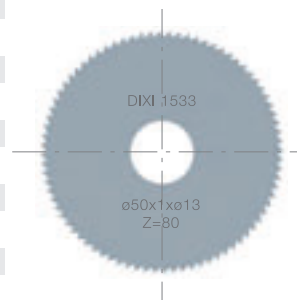

FRAISES À FENDRE DENTURE EXTRA-FINE

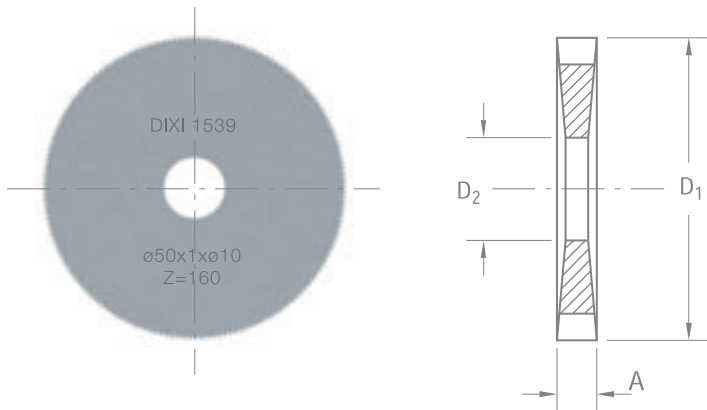

P. 272



Acier + Pb	Acier faibl. allié	Acier fort. allié	Acier inox aust.	Fontes
Super alliages Ni / Co	Titane, alliage de titane	Alliage Cu Argent Or	Alliage Cu difficile	

$D_1 \pm 0.03$	$A \pm 0.005$	$D_2 H6$	Z	CARBURE
10	0.10	3	60	964494
10	0.11	3	60	964499
10	0.12	3	60	964500
10	0.13	3	60	964501
10	0.14	3	60	964502
10	0.15	3	60	964503
10	0.16	3	60	964504
10	0.17	3	60	964505
10	0.18	3	60	964506
10	0.19	3	60	964507
10	0.20	3	60	964508
10	0.22	3	60	965568
10	0.24	3	60	963179
15	0.08	5	80	45005
15	0.10	5	80	40599
15	0.11	5	80	57238
15	0.12	5	80	23559
15	0.13	5	80	46325
15	0.14	5	80	38354
15	0.15	5	80	40588
15	0.16	5	80	28784
15	0.17	5	80	57240
15	0.18	5	80	27224
15	0.19	5	80	46858
15	0.20	5	80	19385
15	0.21	5	80	66021
15	0.23	5	80	58358
15	0.24	5	80	950356
15	0.25	5	80	19823
15	0.30	5	80	26517
15	0.35	5	80	40299
15	0.40	5	80	19825
15	0.50	5	80	19826
15	0.60	5	80	40300
15	0.70	5	80	40301
15	0.80	5	80	40302
15	0.90	5	80	40303
15	1.00	5	80	26518
15	1.10	5	80	40304
15	1.20	5	80	40305
15	1.40	5	80	40306
15	1.50	5	80	33843



DIXI 1539

$D_1 \pm 0.03$	$A \pm 0.005$	$D_2 H6$	Z	CARBURE
20	0.12	5	100	40314
20	0.14	5	100	40307
20	0.15	5	100	43684
20	0.16	5	100	4913
20	0.18	5	100	16032
20	0.20	5	100	4914
20	0.25	5	100	28665
20	0.30	5	100	28340
20	0.35	5	100	40317
20	0.40	5	100	38355
20	0.50	5	100	35628
20	0.60	5	100	40320
20	0.70	5	100	40322
20	0.80	5	100	40324
20	0.90	5	100	40326
20	1.00	5	100	40328
20	1.10	5	100	40330
20	1.20	5	100	40332
20	1.40	5	100	40334
20	1.50	5	100	40336

20	0.12	6	100	40315
20	0.14	6	100	40308
20	0.16	6	100	40309
20	0.18	6	100	40310
20	0.20	6	100	40311
20	0.25	6	100	40312
20	0.30	6	100	40313
20	0.35	6	100	40316
20	0.40	6	100	40318
20	0.50	6	100	40319
20	0.60	6	100	40321
20	0.70	6	100	40323
20	0.80	6	100	40325
20	0.90	6	100	40327
20	1.00	6	100	40329
20	1.10	6	100	40331
20	1.20	6	100	40333
20	1.40	6	100	40335
20	1.50	6	100	40337

$D_1 js10$	$A \pm 0.01$	$D_2 H6$	Z	CARBURE
25	0.20	6	120	3649
25	0.25	6	120	40339
25	0.30	6	120	40341
25	0.35	6	120	40343
25	0.40	6	120	40345
25	0.50	6	120	40347
25	0.60	6	120	40349
25	0.70	6	120	40351
25	0.80	6	120	40353
25	0.90	6	120	40355
25	1.00	6	120	40357
25	1.10	6	120	40359
25	1.20	6	120	40361
25	1.40	6	120	40363
25	1.50	6	120	40365



P. 272



Acier + Pb	Acier faibl. allié	Acier fort. allié	Acier inox aust.	Fontes
Super alliages Ni / Co	Titane, alliage de titane	Alliage Cu Argent Or	Alliage Cu difficile	

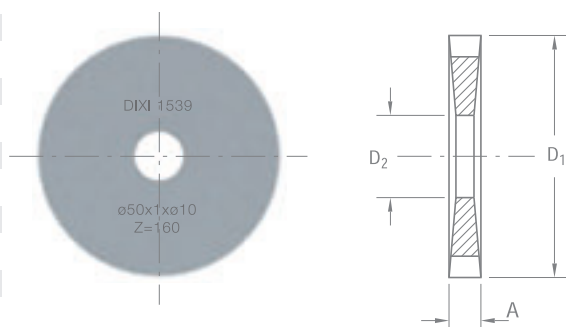

DIXI 1539

$D_1 \pm 0.03$	$A \pm 0.005$	$D_2 H_6$	Z	CARBURE
25	0.20	8	120	40338
25	0.25	8	120	40340
25	0.30	8	120	40342
25	0.35	8	120	40344
25	0.40	8	120	40346
25	0.50	8	120	40348
25	0.60	8	120	40350
25	0.70	8	120	40352
25	0.80	8	120	40354
25	0.90	8	120	40356
25	1.00	8	120	40358
25	1.10	8	120	40360
25	1.20	8	120	40362
25	1.40	8	120	40364
25	1.50	8	120	40366
30	0.30	8	128	40367
30	0.35	8	128	40368
30	0.40	8	128	40369
30	0.50	8	128	40370
30	0.60	8	128	40371
30	0.70	8	128	40372
30	0.80	8	128	40373
30	0.90	8	128	40374
30	1.00	8	128	40375
30	1.10	8	128	40376
30	1.20	8	128	40377
30	1.40	8	128	40378
30	1.50	8	128	40379
40	0.30	8	160	40393
40	0.35	8	160	40395
40	0.40	8	160	40397
40	0.50	8	160	40399
40	0.60	8	160	40401
40	0.70	8	160	40403
40	0.80	8	160	40405
40	0.90	8	160	40407
40	1.00	8	160	40409
40	1.20	8	160	40413
40	1.40	8	160	40415
40	1.50	8	160	40417
40	0.30	10	160	40394
40	0.35	10	160	40396
40	0.40	10	160	40398
40	0.50	10	160	40400
40	0.60	10	160	40402
40	0.70	10	160	40404
40	0.80	10	160	40406
40	0.90	10	160	40408
40	1.00	10	160	40410
40	1.10	10	160	40412
40	1.20	10	160	40414
40	1.50	10	160	40418



P. 272



Acier + Pb	Acier faibl. allié	Acier fort. allié	Acier inox aust.	Fontes
Super alliages Ni / Co	Titane, alliage de titane	Alliage Cu Argent Or	Alliage Cu difficile	

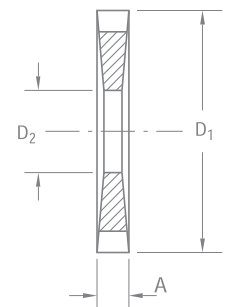
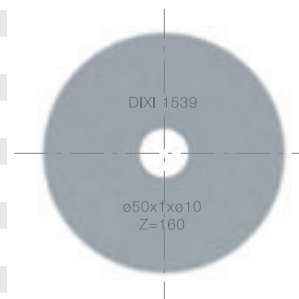



P. 272



Acier + Pb	Acier faibl. allié	Acier fort. allié	Acier inox aust.	Fontes
Super alliages Ni / Co	Titane, alliage de titane	Alliage Cu Argent Or	Alliage Cu difficile	

$D_1 \pm 0.03$	$A \pm 0.005$	$D_2 H6$	Z	CARBURE
50	0.30	10	160	40445
50	0.40	10	160	40447
50	0.50	10	160	40448
50	0.60	10	160	40449
50	0.70	10	160	40450
50	0.80	10	160	40451
50	0.90	10	160	40452
50	1.00	10	160	40453
50	1.20	10	160	40455
50	1.50	10	160	40457

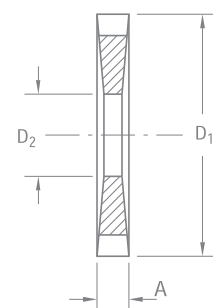
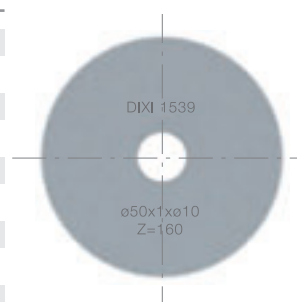

DIXI 1534

FRAISES À FENDRE DENTURE HELLER

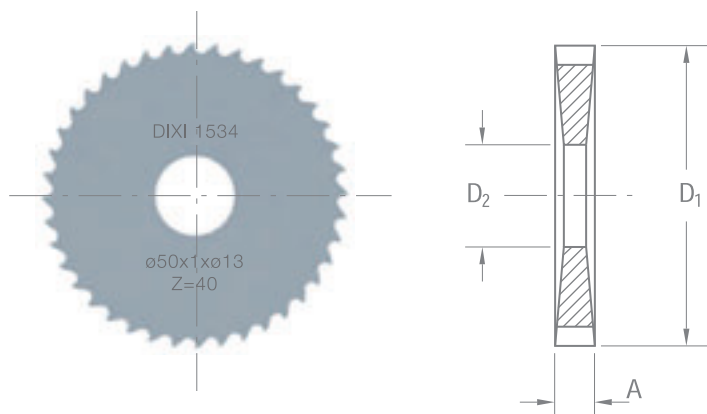

P. 270



Acier + Pb	Acier faibl. allié	Acier fort. allié	Acier inox aust.	Fontes
Super alliages Ni / Co	Titane, alliage de titane	Alliage Cu Argent Or	Alliage Cu difficile	Alu
Plastique				

D_1 js12	A ±0.01	D_2 H6	Z	CARBURE
20	0.30	5	32	34869
20	0.50	5	24	29836
20	0.60	5	24	29541
20	0.70	5	24	29282
20	0.80	5	24	31598
20	0.90	5	24	42581
20	1.00	5	20	39176
20	1.20	5	20	42582
20	1.30	5	20	42583
20	1.50	5	20	31267
20	1.80	5	20	953401
20	2.00	5	16	39550
20	3.00	5	16	42424
25	0.30	8	40	29785
25	0.50	8	32	42427
25	0.60	8	32	42428
25	0.80	8	24	29542
25	0.90	8	24	42430
25	1.00	8	24	30411
25	1.20	8	24	37925
25	1.30	8	24	42431
25	1.50	8	20	38204
25	2.50	8	20	38360
30	0.30	8	40	42434
30	0.40	8	40	42435
30	0.50	8	40	28826
30	0.60	8	32	3308
30	0.70	8	32	38803
30	0.80	8	32	38804
30	1.00	8	32	38806
30	1.20	8	24	36576



DIXI 1534

D_{1js12}	$A_{\pm 0.01}$	D_{2H6}	Z	CARBURE
30	1.30	8	24	38114
30	1.50	8	24	36577
30	1.60	8	24	38756
30	1.80	8	24	36419
30	2.00	8	24	35379
63	0.40	16	64	34999
63	0.50	16	64	2872
63	0.60	16	48	37364
63	0.80	16	48	29794
63	1.00	16	48	28979
63	1.20	16	40	42586
63	1.30	16	40	40597
63	1.50	16	40	28990
63	1.60	16	40	41638
63	1.80	16	40	37787
63	2.00	16	40	28845
63	2.50	16	32	35380
63	3.00	16	32	28828
80	0.80	22	64	36043
80	1.00	22	48	29219
80	1.20	22	48	35967
80	1.50	22	48	18568
80	1.60	22	48	42449
80	2.00	22	40	28829
100	0.80	22	64	35381
100	1.00	22	64	35429
100	1.20	22	64	35431
100	1.50	22	48	25267
100	1.60	22	48	25335
100	2.00	22	48	29408



P. 270



Acier + Pb	Acier faibl. allié	Acier fort. allié	Acier inox aust.	Fontes
Super alliages Ni / Co	Titane, alliage de titane	Alliage Cu Argent Or	Alliage Cu difficile	Alu
Plastique				

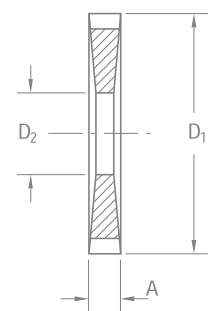
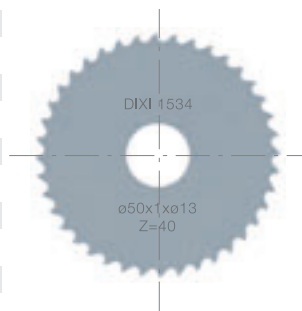

DIXI 1537 CUTINOX

FRAISES À FENDRE POUR ACIERS INOXYDABLES

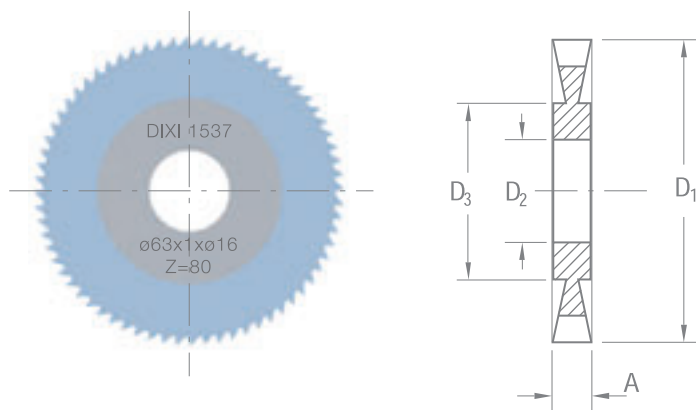

P. 272

Acier
fort.
allié

Acier
inox
aust.

D_1 js12	A ±0.01	D_3	D_2 H6	Z	CUTINOX
50	0.80	30	13	68	954330
50	1.00	30	13	68	954331
63	0.60	40	16	80	60407
63	0.80	40	16	80	60408
63	1.00	40	16	80	60409
80	0.60	50	22	100	60410
80	0.80	50	22	100	60411
80	1.00	50	22	100	60414
100	0.80	60	22	120	60412
100	1.00	60	22	120	60413

DIXI 1640 R + L

FRAISES À TRONÇONNER À DROITE ET À GAUCHE

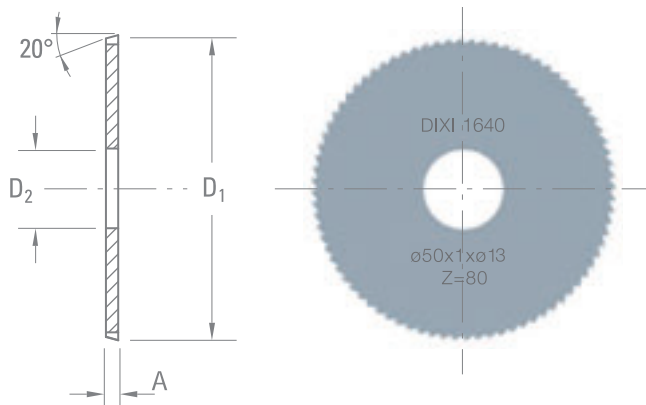

P. 270

Acier + Pb	Acier faibl. allié	Acier fort. allié	Acier inox aust.	Fontes
Super alliages Ni / Co	Titane, alliage de titane	Alliage Cu Argent Or	Alliage Cu difficile	Alu
Plastique				

DIXI 1640 L

D_{1js12}	$A_{\pm 0.01}$	D_{2H6}	Z	CARBURE	CUTINOX
50	0.50	13	100	977529	977548
50	0.80	13	80	977530	957215
50	1.00	13	80	977531	977549
63	0.50	16	128	977532	977552
63	0.80	16	100	954255	977553
63	1.00	16	100	977533	955787
80	0.80	22	128	975393	975569
80	1.00	22	100	977534	977554
100	0.80	22	100	977535	977555
100	1.00	22	100	977536	977556

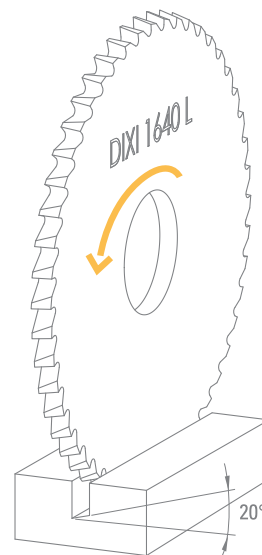

DIXI 1640 R

D_{1js12}	$A_{\pm 0.01}$	D_{2H6}	Z	CARBURE	CUTINOX
50	0.50	13	100	977520	977537
50	0.80	13	80	977521	977538
50	1.00	13	80	59024	977539
63	0.50	16	128	977522	977540
63	0.80	16	100	977523	977541
63	1.00	16	100	977524	977542
80	0.80	22	128	977525	977543
80	1.00	22	100	977526	977544
100	0.80	22	100	977527	977545
100	1.00	22	100	977528	977547

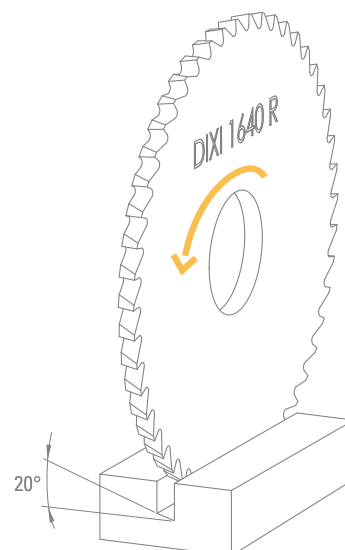

TASSEaux PORTE-FRAISES
AVEC SERRAGE AVANT

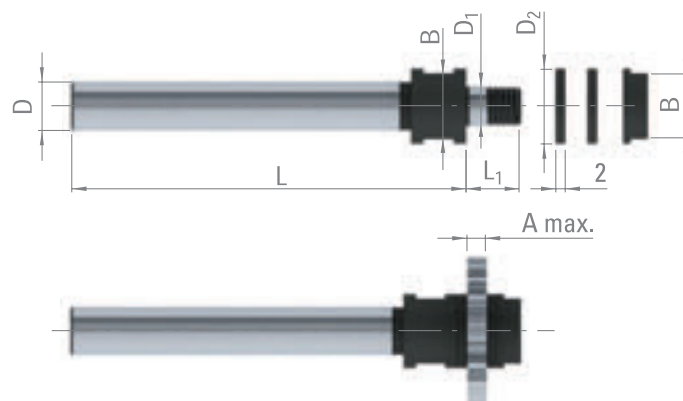

$D_{1\ h6}$	D_{h6}	D_2	L	L_1	B	$A_{\max.}$	Art.
3.00	5	5	60	7.0	4	3	968329
5.00	6	10	70	10.0	8	6	953911
5.00	10	10	80	10.0	8	6	953917
6.00	10	12	80	10.5	10	6	953918
8.00	10	15	80	10.0	13	6	954975
8.00	12	15	90	11.0	13	6	953919
10.00	10	18	80	10.5	15	6	954976
10.00	16	18	100	11.5	15	6	953920
13.00	16	22	110	12.0	19	6	953921
16.00	20	26	120	13.0	22	6	953922



DIXI 2714

TASSEaux PORTE-FRAISES AVEC SERRAGE ARRIÈRE

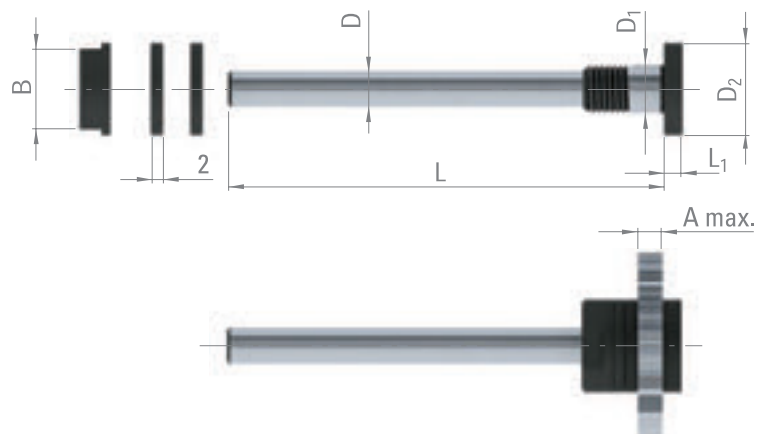

$D_{1\ h6}$	$D_{\ h6}$	D_2	L	L_1	B	$A_{\ max.}$	Art.
5.00	4	10	50	3.0	8	6	953923
6.00	5	12	60	3.0	10	6	953924
8.00	6	15	70	3.0	13	6	953925
8.00	7	15	80	3.0	13	6	953926
10.00	6	18	70	3.5	15	6	953927
10.00	8	18	90	3.5	15	6	953928
13.00	10	22	110	3.5	19	6	953929
16.00	12	26	120	3.5	22	6	953930



FRAISES À T
DENTURE DROITE



P. 274

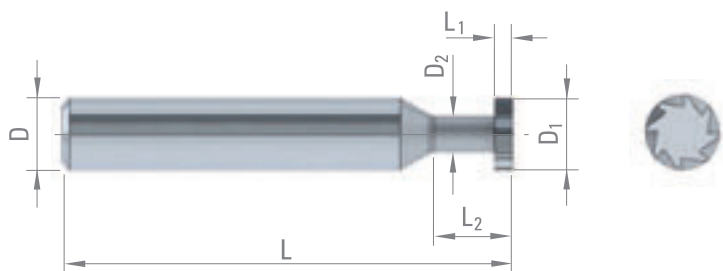

- Acier + Pb
- Acier faibl. allié
- Acier inox aust.
- Titane, alliage de titane
- Alliage Cu Argent Or
- Alu
- Plastique

D ₁ ∅ < 4.0 ±0.01 ∅ ≥ 4.0 -0.05/-0.10	L ₁	D ₂ 0/-0.20	L ₂ ±0.2	D _{h5}	L	Z	CARBURE	CUTINOX
2.0	0.2 - 1.0	1.0	3.0	4	42	3 - 6	<input type="checkbox"/>	<input checked="" type="checkbox"/>
3.0	0.2 - 1.5	1.5	3.5	4	42	3 - 6	<input type="checkbox"/>	<input checked="" type="checkbox"/>
4.0	0.2 - 1.5	2.5	6.0	4	42	3 - 6	<input type="checkbox"/>	<input checked="" type="checkbox"/>
5.0	0.5 - 1.5	3.0	6.0	5	42	3 - 6	<input type="checkbox"/>	<input checked="" type="checkbox"/>
6.0	0.5 - 2.5	3.5	7.0	6	42	4 - 8	<input type="checkbox"/>	<input checked="" type="checkbox"/>
8.0	0.5 - 3.0	4.0	9.0	8	50	5 - 10	<input type="checkbox"/>	<input checked="" type="checkbox"/>
10.0	0.5 - 4.0	5.0	9.0	10	50	5 - 12	<input type="checkbox"/>	<input checked="" type="checkbox"/>
12.0	0.5 - 3.5	5.0	11.5	6	50	6 - 16	<input type="checkbox"/>	<input checked="" type="checkbox"/>
12.0	0.5 - 4.0	6.0	14.0	10	50	6 - 16	<input type="checkbox"/>	<input checked="" type="checkbox"/>
15.0	0.5 - 5.0	8.0	14.0	10	60	8 - 18	<input type="checkbox"/>	<input checked="" type="checkbox"/>
16.0	0.5 - 2.9	8.0	14.0	10	60	8 - 20	<input type="checkbox"/>	<input checked="" type="checkbox"/>
16.0	3.0 - 6.0	8.0	14.0	10	60	8 - 20	<input type="checkbox"/>	<input checked="" type="checkbox"/>
18.0	0.5 - 2.9	8.0	14.0	10	60	10 - 24	<input type="checkbox"/>	<input checked="" type="checkbox"/>
18.0	3.0 - 6.0	8.0	14.0	10	60	10 - 24	<input type="checkbox"/>	<input checked="" type="checkbox"/>
20.0	0.5 - 2.9	8.0	11.0	10	60	10 - 24	<input type="checkbox"/>	<input checked="" type="checkbox"/>
20.0	3.0 - 6.0	8.0	14.0	10	60	10 - 24	<input type="checkbox"/>	<input checked="" type="checkbox"/>
25.0	0.5 - 3.9	8.0	13.0	10	60	10 - 32	<input type="checkbox"/>	<input checked="" type="checkbox"/>
25.0	4.0 - 8.0	8.0	18.0	10	60	10 - 32	<input type="checkbox"/>	<input checked="" type="checkbox"/>
30.0	0.5 - 3.9	8.0	13.0	10	60	10 - 36	<input type="checkbox"/>	<input checked="" type="checkbox"/>
30.0	4.0 - 8.0	8.0	18.0	10	60	10 - 36	<input type="checkbox"/>	<input checked="" type="checkbox"/>

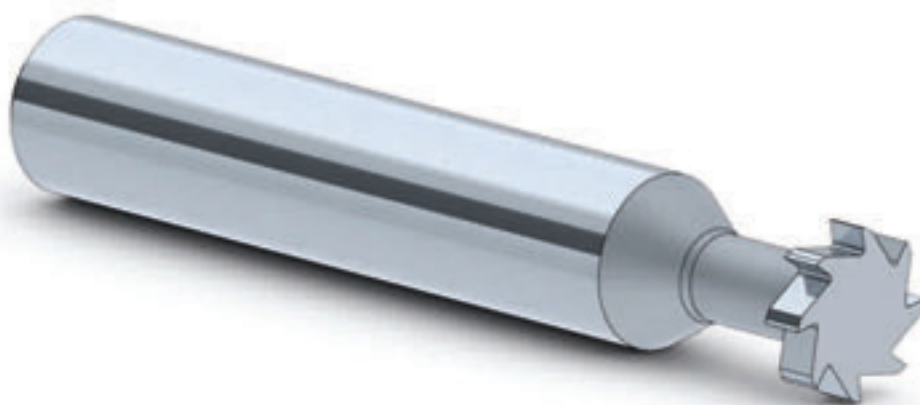

FRAISES À T
DENTURE ALTERNÉE



P. 274

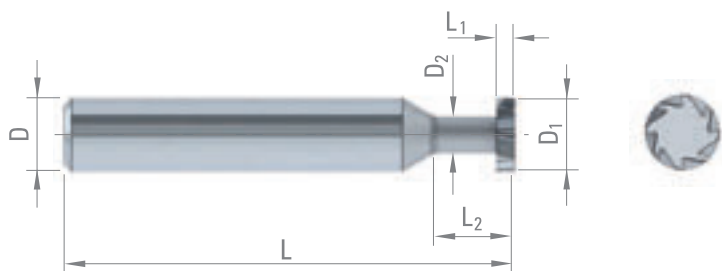

- Acier + Pb
- Acier faibl. allié
- Acier inox aust.
- Titane, alliage de titane
- Alliage Cu Argent Or
- Alu
- Plastique

D ₁ Ø < 4.0 ±0.01 Ø ≥ 4.0 -0.05/-0.10	L ₁	D ₂ 0/-0.20	L ₂ ±0.2	D _{h5}	L	Z	CARBURE	CUTINOX
4.0	0.5 - 3.0	2.5	6.0	4	42	4 - 6	<input type="checkbox"/>	<input checked="" type="checkbox"/>
5.0	0.5 - 3.0	3.0	6.0	5	42	4 - 6	<input type="checkbox"/>	<input checked="" type="checkbox"/>
6.0	0.5 - 3.0	3.5	7.0	6	42	4 - 6	<input type="checkbox"/>	<input checked="" type="checkbox"/>
8.0	1.0 - 4.0	4.0	9.0	8	50	4 - 8	<input type="checkbox"/>	<input checked="" type="checkbox"/>
10.0	1.0 - 4.0	5.0	9.0	10	50	6 - 10	<input type="checkbox"/>	<input checked="" type="checkbox"/>
12.0	0.5 - 3.5	5.0	11.5	6	50	6 - 10	<input type="checkbox"/>	<input checked="" type="checkbox"/>
12.0	1.0 - 5.0	6.0	14.0	10	50	6 - 10	<input type="checkbox"/>	<input checked="" type="checkbox"/>
15.0	1.5 - 6.0	8.0	14.0	10	60	8 - 14	<input type="checkbox"/>	<input checked="" type="checkbox"/>
16.0	1.5 - 3.9	8.0	14.0	10	60	8 - 14	<input type="checkbox"/>	<input checked="" type="checkbox"/>
16.0	4.0 - 6.0	8.0	14.0	10	60	8 - 14	<input type="checkbox"/>	<input checked="" type="checkbox"/>
18.0	1.5 - 3.9	8.0	14.0	10	60	10 - 16	<input type="checkbox"/>	<input checked="" type="checkbox"/>
18.0	4.0 - 6.0	8.0	14.0	10	60	10 - 16	<input type="checkbox"/>	<input checked="" type="checkbox"/>
20.0	1.5 - 3.9	8.0	11.0	10	60	10 - 18	<input type="checkbox"/>	<input checked="" type="checkbox"/>
20.0	4.0 - 6.0	8.0	14.0	10	60	10 - 18	<input type="checkbox"/>	<input checked="" type="checkbox"/>
25.0	1.5 - 4.9	8.0	13.0	10	60	10 - 24	<input type="checkbox"/>	<input checked="" type="checkbox"/>
25.0	5.0 - 10.0	8.0	18.0	10	60	14 - 24	<input type="checkbox"/>	<input checked="" type="checkbox"/>
30.0	1.5 - 4.9	8.0	13.0	10	60	18 - 28	<input type="checkbox"/>	<input checked="" type="checkbox"/>
30.0	5.0 - 10.0	8.0	18.0	10	60	18 - 28	<input type="checkbox"/>	<input checked="" type="checkbox"/>

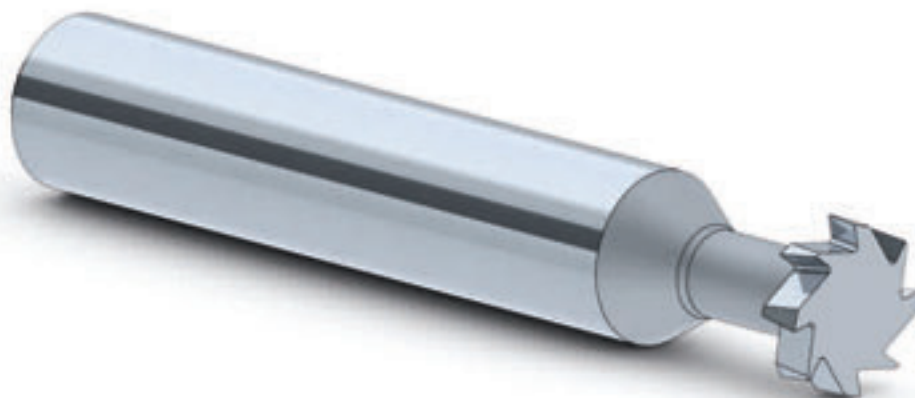

FRAISES À T
1/2 RONDES, CONVEXES



P. 274

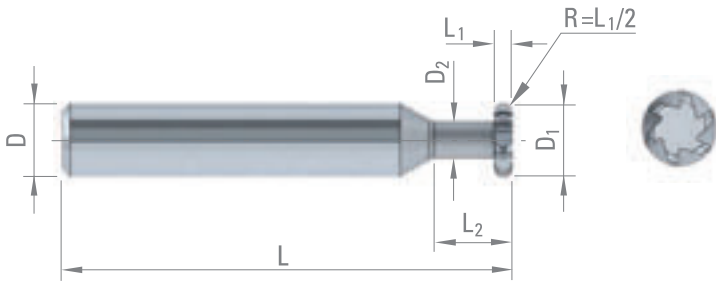

- Acier + Pb
- Acier faibl. allié
- Acier inox aust.
- Titane, alliage de titane
- Alliage Cu Argent Or
- Alu
- Plastique

D ₁ ∅ < 4.0 ±0.03 ∅ ≥ 4.0 -0.05/-0.10	L ₁	D ₂ 0/-0.20	L ₂ ±0.2	D _{h5}	L	Z	CARBURE	CUTINOX
4.0	0.4 - 1.5	1.5	6.0	4	42	4	<input type="checkbox"/>	<input checked="" type="checkbox"/>
6.0	0.5 - 2.0	3.5	7.0	6	42	6	<input type="checkbox"/>	<input checked="" type="checkbox"/>
8.0	1.0 - 3.0	4.0	9.0	8	50	6	<input type="checkbox"/>	<input checked="" type="checkbox"/>
10.0	1.0 - 4.0	5.0	9.0	10	50	8	<input type="checkbox"/>	<input checked="" type="checkbox"/>
12.0	0.5 - 3.5	5.0	11.5	6	50	10	<input type="checkbox"/>	<input checked="" type="checkbox"/>
12.0	1.0 - 5.0	6.0	14.0	10	50	10	<input type="checkbox"/>	<input checked="" type="checkbox"/>
16.0	1.0 - 6.0	8.0	14.0	10	60	12	<input type="checkbox"/>	<input checked="" type="checkbox"/>

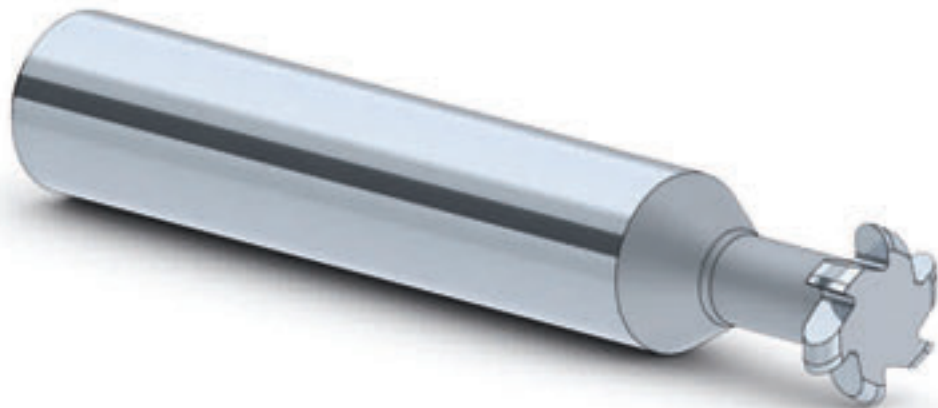

Autres possibilités de dentures et formes page 269



FRAISES-MÈRES
EPICYCLOÏDALES ET DÉVELOPPANTES

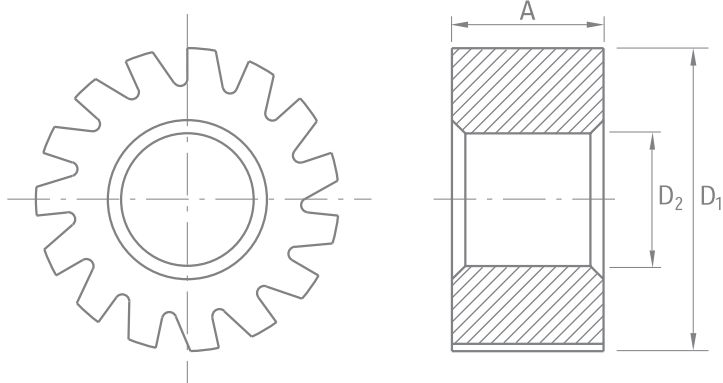

- | | | | | |
|----------------------|----------------------|-------------------|------------------|---------------------------|
| Acier + Pb | Acier faibl. allié | Acier fort. allié | Acier inox aust. | Titane, alliage de titane |
| Alliage Cu Argent Or | Alliage Cu difficile | Alu | | |

Module (m) = 0.04 - 1.00

D ₁	A	D _{2 H3}	Z	CARBURE
6	4	3.5	12	□
	5	3.5	12	□
	6	3.5	12	□
8	4	3.5	15	□
	5	3.5	12	□
10	6	3.5	12	□
	4	3.5	15	□
	5	3.5	12	□
	6	3.5	12	□
	6	4.5	12	□
	6	4.5	15	□
12	6	3.5	15	□
	6	4.5	12	□
	6	4.5	15	□
	6	5.0	12	□
	6	5.0	15	□
	6	6.0	12	□
	6	6.0	15	□
	8	4.5	15	□
	8	5.0	15	□
	8	6.0	15	□
16	10	8.0	12	□
	6	8.0	12	□
	6	8.0	15	□
	8	8.0	12	□
	8	8.0	15	□
	10	8.0	12	□
18	10	8.0	15	□
	10	8.0	12	□
	12	8.0	12	□
	12	8.0	15	□
	6	6.0	12	□
	6	8.0	12	□
	6	8.0	15	□
24	8	8.0	12	□
	8	8.0	15	□
	10	8.0	12	□
	10	8.0	15	□
	12	8.0	12	□
	12	8.0	15	□
	16	8.0	12	□
	16	8.0	15	□
	16	10.0	12	□

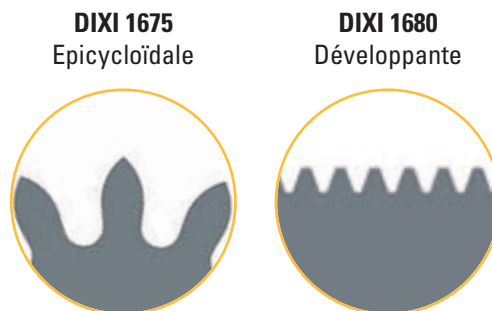

Profil logarithmique réaffûtable



Revêtements sur demande



FRAISES-MÈRES
INDEX

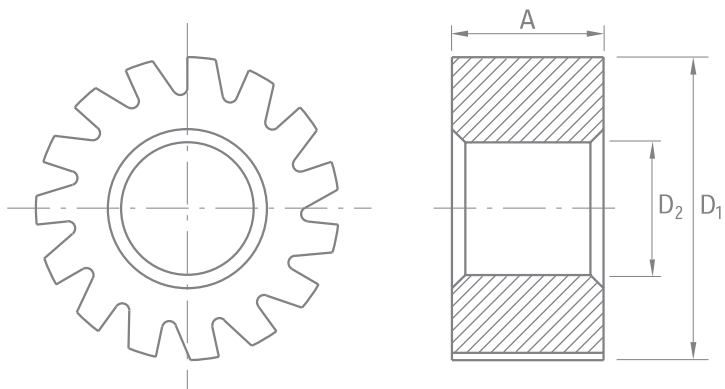

- | | | | | |
|----------------------|----------------------|-------------------|------------------|---------------------------|
| Acier + Pb | Acier faibl. allié | Acier fort. allié | Acier inox aust. | Titane, alliage de titane |
| Alliage Cu Argent Or | Alliage Cu difficile | Alu | | |

D ₁	A	D _{2 H3}	Z	CARBURE
6	4	3.5	12	<input type="checkbox"/>
6	5	3.5	12	<input type="checkbox"/>
6	6	3.5	12	<input type="checkbox"/>
8	5	3.5	12	<input type="checkbox"/>
8	6	3.5	12	<input type="checkbox"/>
10	5	3.5	12	<input type="checkbox"/>
10	6	3.5	12	<input type="checkbox"/>
10	6	4.5	12	<input type="checkbox"/>
12	6	4.5	12	<input type="checkbox"/>
12	6	5.0	12	<input type="checkbox"/>
12	6	6.0	12	<input type="checkbox"/>
16	6	8.0	12	<input type="checkbox"/>
16	8	8.0	12	<input type="checkbox"/>
16	10	8.0	12	<input type="checkbox"/>
18	6	6.0	12	<input type="checkbox"/>
18	8	8.0	12	<input type="checkbox"/>
18	10	8.0	12	<input type="checkbox"/>
24	6	8.0	12	<input type="checkbox"/>
24	8	8.0	12	<input type="checkbox"/>
24	10	8.0	12	<input type="checkbox"/>
24	12	8.0	12	<input type="checkbox"/>

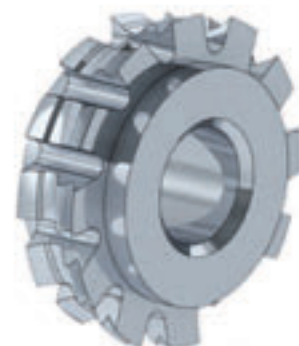

FRAISES-MÈRES
TAILLAGE FRONTAL

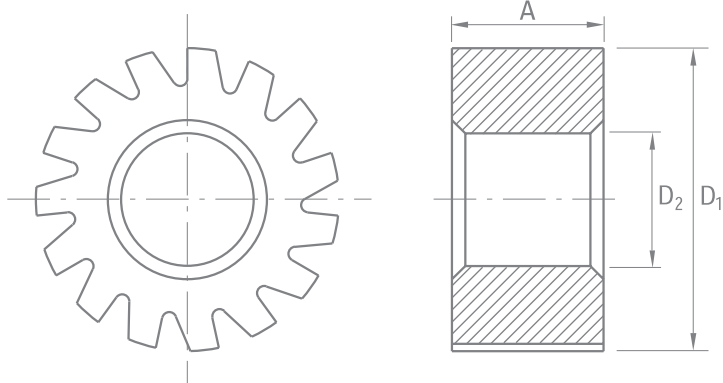

- | | | | | |
|----------------------|----------------------|-------------------|------------------|---------------------------|
| Acier + Pb | Acier faibl. allié | Acier fort. allié | Acier inox aust. | Titane, alliage de titane |
| Alliage Cu Argent Or | Alliage Cu difficile | Alu | | |

Module (m) = 0.03 - 1.00

D ₁	A	D _{2 H3}	Z	CARBURE
10	2	4.5	4	<input type="checkbox"/>
10	2	4.5	5	<input type="checkbox"/>
10	2	4.5	6	<input type="checkbox"/>
12	2	4.5	2	<input type="checkbox"/>
12	2	4.5	3	<input type="checkbox"/>
12	2	4.5	4	<input type="checkbox"/>
12	2	4.5	5	<input type="checkbox"/>
12	2	4.5	6	<input type="checkbox"/>



FRAISES MODULE
TAILLAGE DENT PAR DENT

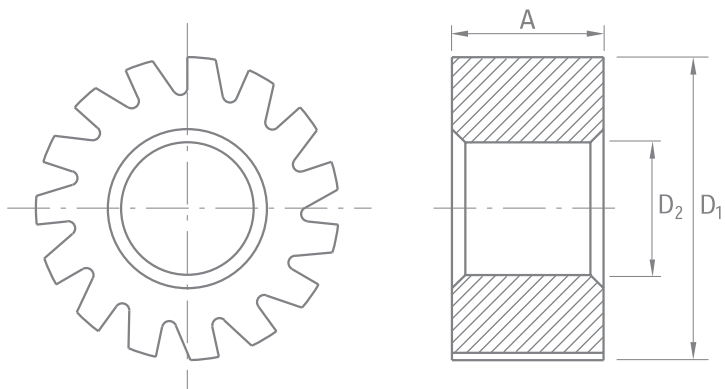

- Acier + Pb
- Acier faibl. allié
- Acier fort. allié
- Acier inox aust.
- Titane, alliage de titane
- Alliage Cu Argent Or
- Alliage Cu difficile
- Alu

Module (m) = 0.03 - 1.00

D ₁	A	D _{2H3}	Z	CARBURE
6	4	3.5	12	<input type="checkbox"/>
8	5	3.5	12	<input type="checkbox"/>
8	6	3.5	12	<input type="checkbox"/>
10	2	3.5	12	<input type="checkbox"/>
10	2	4.5	12	<input type="checkbox"/>
10	2	5.0	12	<input type="checkbox"/>
10	5	3.5	12	<input type="checkbox"/>
10	6	3.5	12	<input type="checkbox"/>
12	2	3.5	12	<input type="checkbox"/>
12	2	4.5	12	<input type="checkbox"/>
12	6	5.0	12	<input type="checkbox"/>
16	6	8.0	12	<input type="checkbox"/>
18	6	8.0	12	<input type="checkbox"/>
24	6	8.0	12	<input type="checkbox"/>





OUTILS SUR DEMANDE

Norme _____

Plan _____

DXF _____

Matière à usiner _____

Module (m) _____

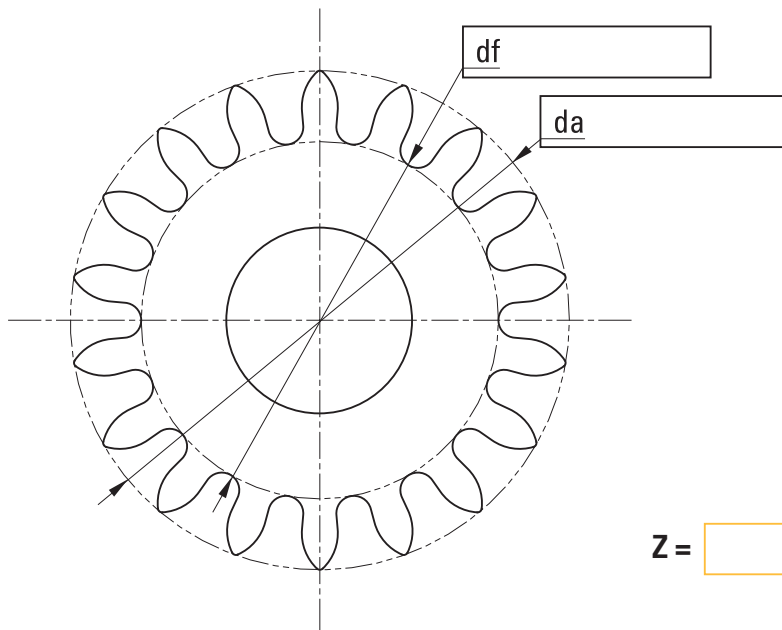

Z =

D_1 _____

A _____

D_2 _____

Angle d'hélice (profil) R L

Nombre de filets _____

Revêtement _____

Quantité _____

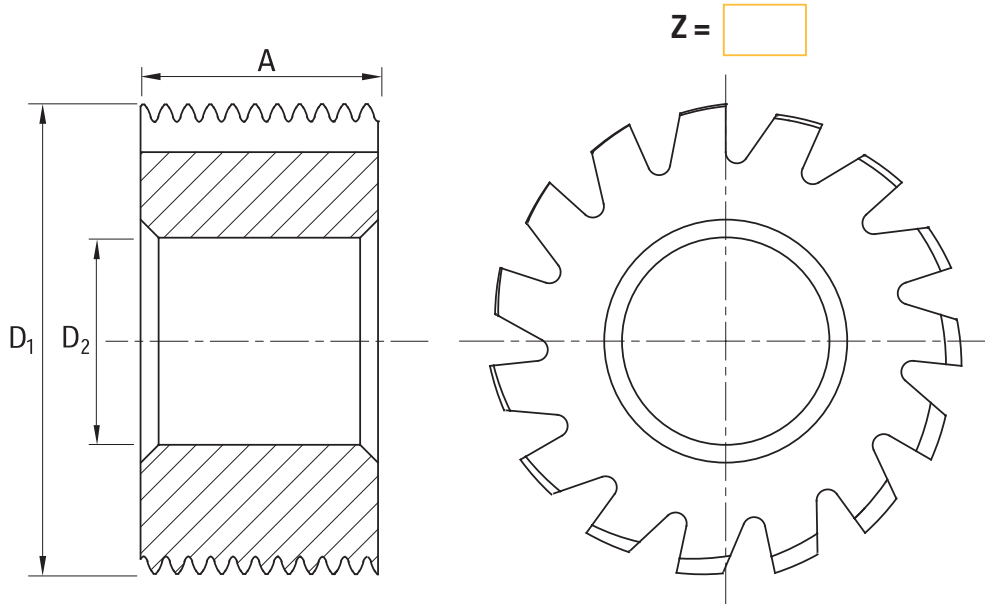

Z =

Remarques





OUTILS SUR DEMANDE

Norme

Plan

DXF

Matière à usiner

Module (m)

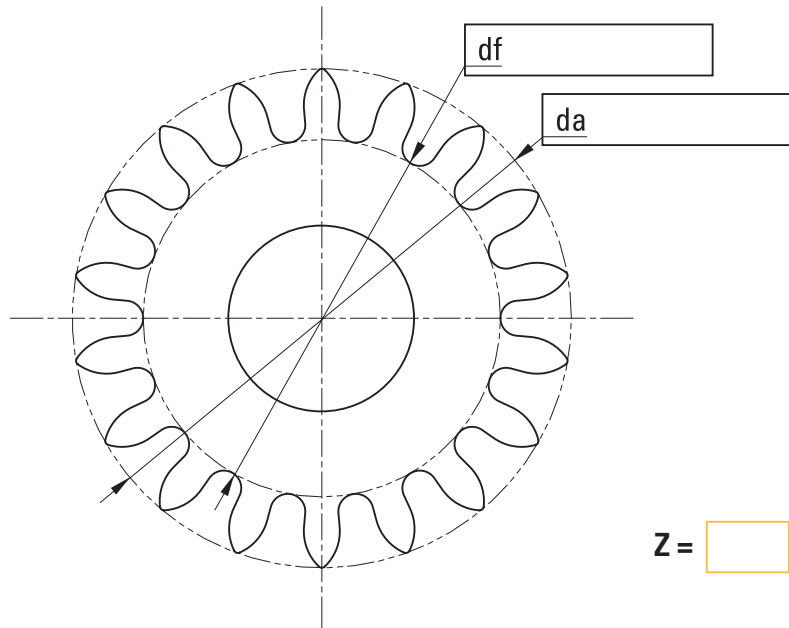

D_1

A

D_2

Revêtement

Quantité

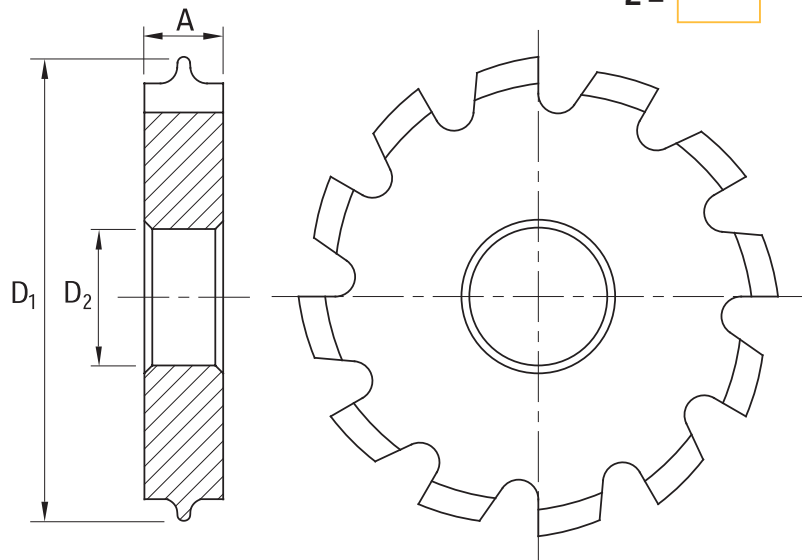

Remarques



OUTILS SUR DEMANDE

Quantités

Matière à usiner

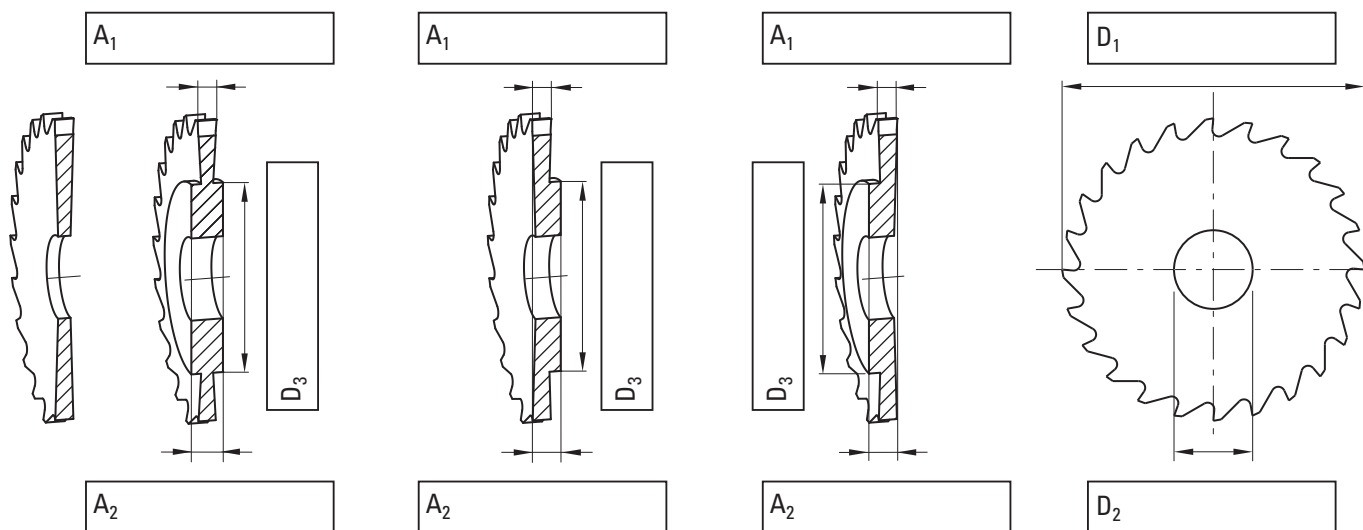

1640 L

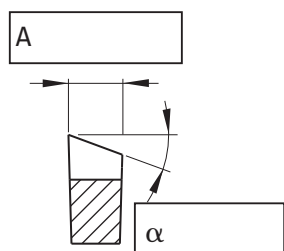

1640 R

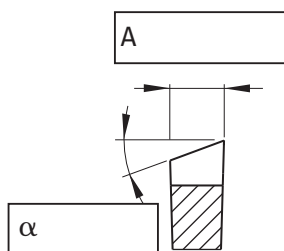

1643

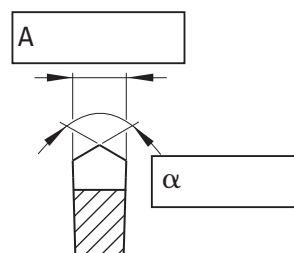

1650

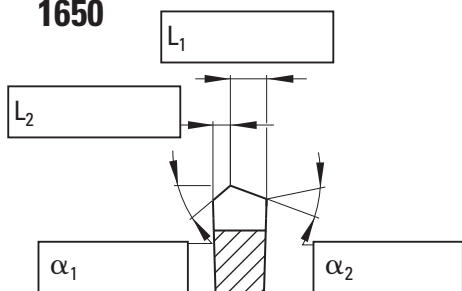

1650

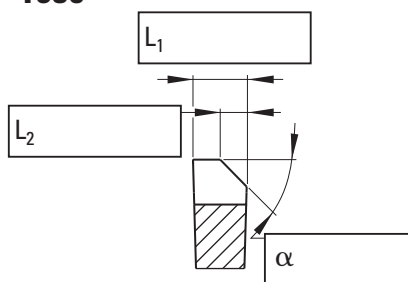

1650

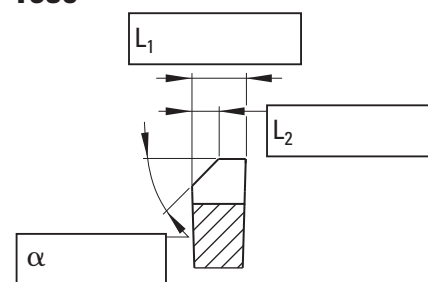

1650

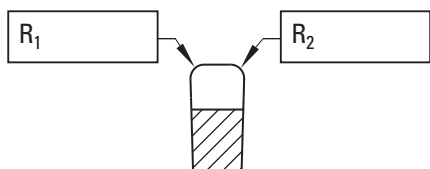

1654

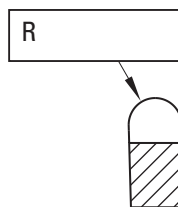

1650

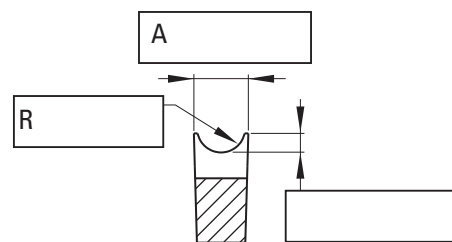



OUTILS SUR DEMANDE

FRAISES À T

Z =

Quantités

Matière à usiner

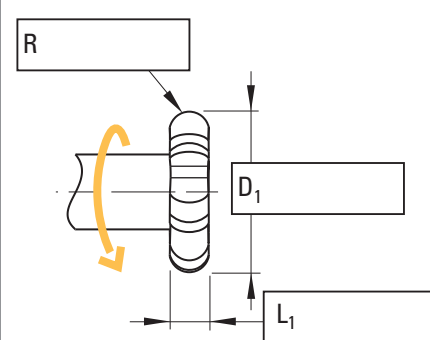
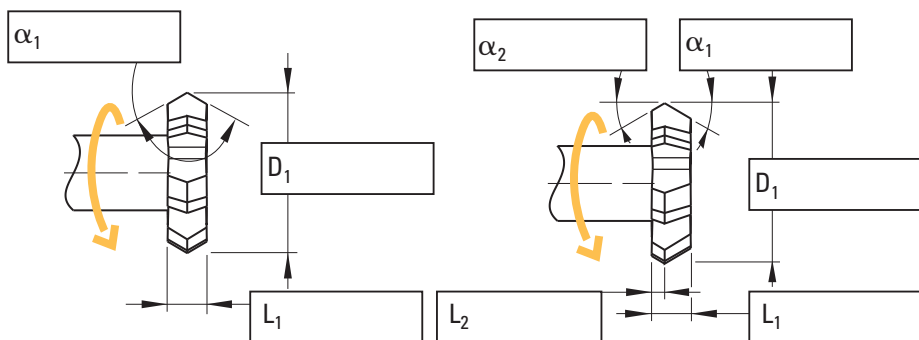
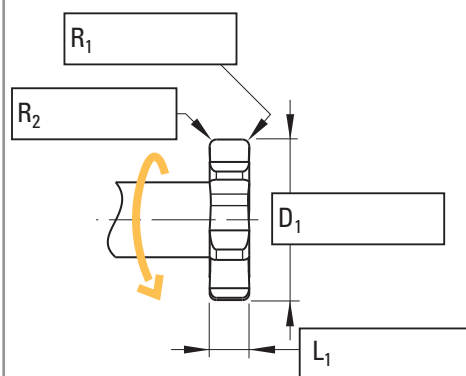
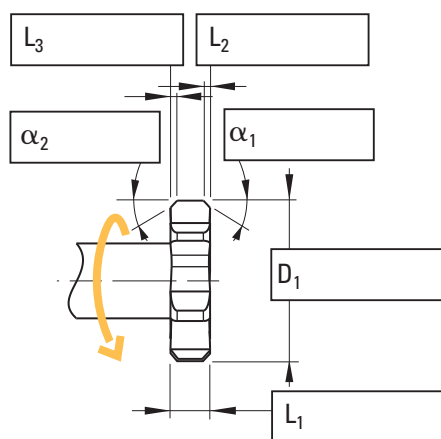
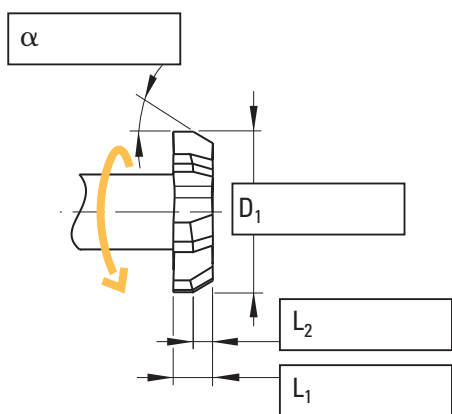
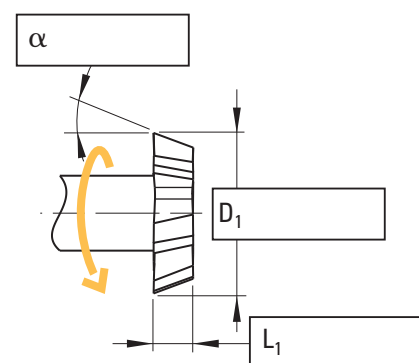
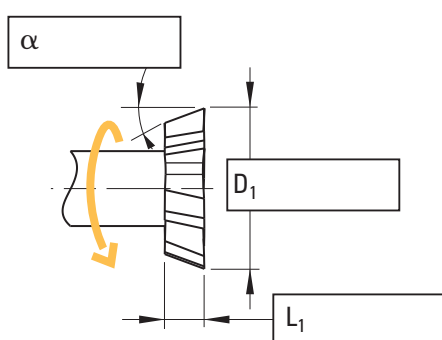
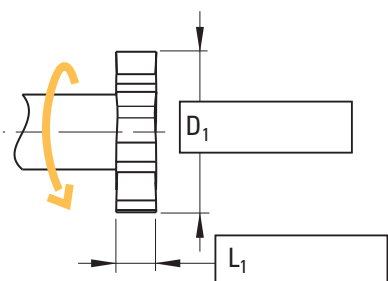
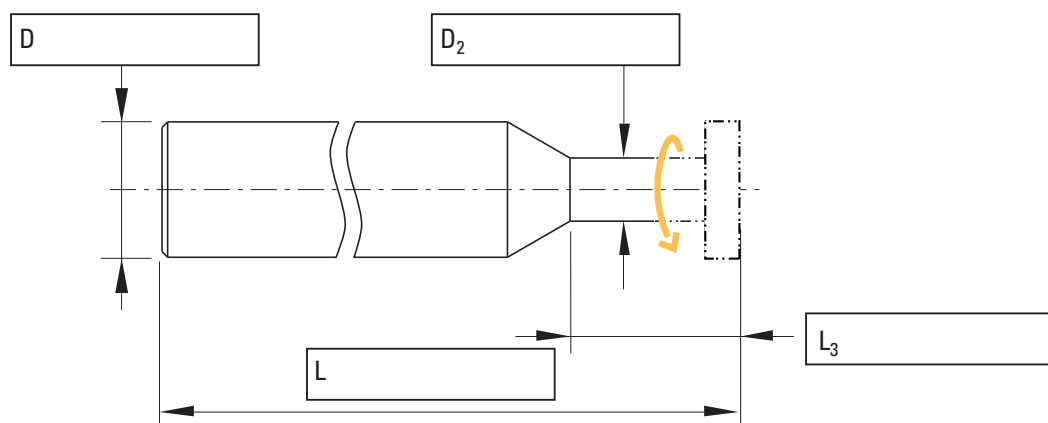

CONSULTEZ NOTRE FORMULAIRE DE DEMANDE D'OFFRES EN LIGNE SUR WWW.DIXIPOLYTOOL.COM



CONDITIONS DE COUPE

Matières à usiner			CARBURE	
			Vc [m/min]	
P	Acier non allié / faiblement allié	< 600 N/mm ²	80	140
P	Acier non allié / faiblement allié	600 – 1500 N/mm ²	50	80
P	Acier de décolletage au plomb		120	160
P	Acier fortement allié	700 – 1500 N/mm ²	50	80
M	Acier inoxydable	400 – 700 N/mm ²	80	120
M	Acier inox. DUPLEX, acier austénitique inox. sans nickel	> 800 N/mm ²	50	80
K	Fonte grise / Fonte à graphite sphéroïdal perlitique	< 250 HB	80	140
K	Fonte alliée / Fonte à graphite sphéroïdal perlitique	> 250 HB	50	80
K	Fonte à graphite sphéroïdal ferritique / Fonte malléable		50	80
S	Super alliages / Acier inox. réfractaire	Inconel Nimonic Hastelloy	20	30
S	Titane, alliage de titane		30	70
N	Alliage de cuivre / bonne usinabilité (laiton – bronze)		200	450
N	Alliage de cuivre / usinabilité difficile / Bronze à l'aluminium	(CuAlFe) (Ampco)	150	300
N	Alliage d'aluminium	Si < 8%	200	500
N	Fonte d'aluminium	Si > 8%	200	450
N	Plastique		130	200
N	Or, argent		140	180



$$n \text{ [tr/min]} = \frac{Vc \text{ [m/min]} \times 1000}{\pi \times D_1 \text{ [mm]}}$$

$$Vf \text{ [mm/min]} = n \text{ [tr/min]} \times fz \text{ [mm]} \times z$$

Avance par dent **fz [mm]**

$\emptyset D_1$ 15 - 30	$\emptyset D_1$ 30 - 50	$\emptyset D_1$ 50 - 80	$\emptyset D_1$ 80 - 125	$\emptyset D_1$ 125 - 160
0.002 - 0.004	0.003 - 0.007	0.004 - 0.008	0.004 - 0.012	0.004 - 0.012
0.001 - 0.004	0.002 - 0.005	0.002 - 0.008	0.003 - 0.012	0.003 - 0.012
0.003 - 0.007	0.004 - 0.008	0.005 - 0.010	0.005 - 0.010	0.005 - 0.012
0.001 - 0.004	0.002 - 0.005	0.002 - 0.008	0.003 - 0.012	0.003 - 0.012
0.001 - 0.004	0.002 - 0.005	0.002 - 0.008	0.003 - 0.012	0.003 - 0.012
0.001 - 0.004	0.002 - 0.005	0.002 - 0.008	0.003 - 0.012	0.003 - 0.012
0.002 - 0.004	0.003 - 0.007	0.004 - 0.01	0.004 - 0.01	0.004 - 0.01
0.001 - 0.004	0.002 - 0.005	0.002 - 0.008	0.003 - 0.012	0.003 - 0.012
0.002 - 0.004	0.003 - 0.007	0.004 - 0.01	0.004 - 0.01	0.004 - 0.01
0.001 - 0.004	0.002 - 0.005	0.002 - 0.008	0.003 - 0.012	0.003 - 0.012
0.001 - 0.004	0.002 - 0.005	0.002 - 0.008	0.003 - 0.012	0.003 - 0.012
0.003 - 0.007	0.004 - 0.008	0.005 - 0.010	0.005 - 0.010	0.005 - 0.012
0.001 - 0.004	0.002 - 0.005	0.002 - 0.008	0.003 - 0.012	0.003 - 0.012
0.003 - 0.007	0.004 - 0.008	0.005 - 0.010	0.005 - 0.010	0.005 - 0.012
0.003 - 0.007	0.004 - 0.008	0.005 - 0.010	0.005 - 0.010	0.005 - 0.012
0.003 - 0.010	0.004 - 0.010	0.005 - 0.012	0.005 - 0.012	0.005 - 0.015
0.003 - 0.007	0.004 - 0.008	0.005 - 0.010	0.005 - 0.010	0.005 - 0.012



CONDITIONS DE COUPE

Matières à usiner			CUTINOX	
			Vc [m/min]	
P	Acier fortement allié	700 – 1500 N/mm ²	100	150
M	Acier inoxydable	400 – 700 N/mm ²	250	400
M	Acier inox. DUPLEX, acier austénitique inox. sans nickel	> 800 N/mm ²	100	150

Matières à usiner			CARBURE	
			Vc [m/min]	
P	Acier non allié / faiblement allié	< 600 N/mm ²	80	140
P	Acier non allié / faiblement allié	600 – 1500 N/mm ²	50	80
P	Acier de décolletage au plomb		120	160
P	Acier fortement allié	700 – 1500 N/mm ²	50	80
M	Acier inoxydable	400 – 700 N/mm ²	80	120
M	Acier inox. DUPLEX, acier austénitique inox. sans nickel	> 800 N/mm ²	50	80
K	Fonte grise / Fonte à graphite sphéroïdal perlitique	< 250 HB	80	140
K	Fonte alliée / Fonte à graphite sphéroïdal perlitique	> 250 HB	50	80
K	Fonte à graphite sphéroïdal ferritique / Fonte malléable		50	80
S	Super alliages / Acier inox. réfractaire	Inconel Nimonic Hastelloy	20	30
S	Titane, alliage de titane		30	70
N	Alliage de cuivre / bonne usinabilité (laiton – bronze)		200	450
N	Alliage de cuivre / usinabilité difficile / Bronze à l'aluminium	(CuAlFe) (Ampco)	150	300



$$n \text{ [tr/min]} = \frac{Vc \text{ [m/min]} \times 1000}{\pi \times D_1 \text{ [mm]}}$$

$$Vf \text{ [mm/min]} = n \text{ [tr/min]} \times fz \text{ [mm]} \times z$$

Avance par dent **fz [mm]**

$\emptyset D_1$ 50	$\emptyset D_1$ 63	$\emptyset D_1$ 80	$\emptyset D_1$ 100
0.002 - 0.008	0.002 - 0.008	0.002 - 0.008	0.002 - 0.008
0.002 - 0.008	0.002 - 0.008	0.002 - 0.008	0.002 - 0.008
0.002 - 0.008	0.002 - 0.008	0.002 - 0.008	0.002 - 0.008

Avance par dent **fz [mm]**

$\emptyset D_1$ 15 - 30	$\emptyset D_1$ 30 - 40	$\emptyset D_1$ 40 - 50
0.0003 - 0.002	0.0003 - 0.002	0.0003 - 0.002
0.0003 - 0.002	0.0003 - 0.002	0.0003 - 0.002
0.0003 - 0.002	0.0003 - 0.002	0.0003 - 0.002
0.0003 - 0.002	0.0003 - 0.002	0.0003 - 0.002
0.0003 - 0.002	0.0003 - 0.002	0.0003 - 0.002
0.0003 - 0.002	0.0003 - 0.002	0.0003 - 0.002
0.0003 - 0.002	0.0003 - 0.002	0.0003 - 0.002
0.0003 - 0.002	0.0003 - 0.002	0.0003 - 0.002
0.0003 - 0.002	0.0003 - 0.002	0.0003 - 0.002
0.0003 - 0.002	0.0003 - 0.002	0.0003 - 0.002
0.0003 - 0.002	0.0003 - 0.002	0.0003 - 0.002
0.0003 - 0.002	0.0003 - 0.002	0.0003 - 0.002
0.0003 - 0.002	0.0003 - 0.002	0.0003 - 0.002
0.0003 - 0.002	0.0003 - 0.002	0.0003 - 0.002



CONDITIONS DE COUPE

Matières à usiner			CARBURE	CUTINOX
			Vc [m/min]	Vc [m/min]
P	Acier non allié / faiblement allié	< 600 N/mm ²	70 100	
P	Acier non allié / faiblement allié	600 – 1500 N/mm ²	70 90	
P	Acier de décolletage au plomb			70 100
P	Acier fortement allié	700 – 1500 N/mm ²	40 70	
M	Acier inoxydable	400 – 700 N/mm ²		60 90
M	Acier inox. DUPLEX, acier austénitique inox. sans nickel	> 800 N/mm ²		40 70
K	Fonte grise / Fonte à graphite sphéroïdal perlitique	< 250 HB	70 100	90 110
K	Fonte alliée / Fonte à graphite sphéroïdal perlitique	> 250 HB	40 70	70 90
K	Fonte à graphite sphéroïdal ferritique / Fonte malléable		70 100	90 110
S	Super alliages / Acier inox. réfractaire	Inconel Nimonic Hastelloy		25 35
N	Titane, alliage de titane		30 45	
N	Alliage de cuivre / bonne usinabilité (laiton – bronze)		140 160	
N	Alliage de cuivre / usinabilité difficile / Bronze à l'aluminium (CuAlFe) (Ampco)		120 140	170 190
N	Alliage d'aluminium	Si < 8%	180 260	230 340
N	Fonte d'aluminium	Si > 8%	140 160	210 230
N	Plastique		240 260	300 340
N	Or, argent		140 160	200 220



$$n \text{ [tr/min]} = \frac{Vc \text{ [m/min]} \times 1000}{\pi \times D_1 \text{ [mm]}}$$

$$Vf \text{ [mm/min]} = n \text{ [tr/min]} \times fz \text{ [mm]} \times Z$$

Avance par dent **fz [mm]**

Ø D ₁ 2.00 - 5.00	Ø D ₁ 5.00 - 8.00	Ø D ₁ 8.00 - 12.00	Ø D ₁ 12.00 - 15.00	Ø D ₁ 15.00 - 20.00	Ø D ₁ 20.00 - 25.00	Ø D ₁ 25.00 - 30.00
0.003 - 0.007	0.005 - 0.011	0.007 - 0.015	0.010 - 0.019	0.015 - 0.028	0.020 - 0.040	0.030 - 0.060
0.003 - 0.007	0.005 - 0.011	0.007 - 0.015	0.010 - 0.019	0.015 - 0.028	0.020 - 0.040	0.030 - 0.060
0.003 - 0.007	0.005 - 0.011	0.007 - 0.015	0.010 - 0.019	0.015 - 0.028	0.020 - 0.040	0.030 - 0.060
0.003 - 0.007	0.005 - 0.011	0.007 - 0.015	0.010 - 0.019	0.015 - 0.028	0.020 - 0.040	0.030 - 0.060
0.003 - 0.007	0.005 - 0.011	0.007 - 0.015	0.010 - 0.019	0.015 - 0.028	0.020 - 0.040	0.030 - 0.060
0.003 - 0.007	0.005 - 0.011	0.007 - 0.015	0.010 - 0.019	0.015 - 0.028	0.020 - 0.040	0.030 - 0.060
0.003 - 0.007	0.005 - 0.011	0.007 - 0.015	0.010 - 0.019	0.015 - 0.028	0.020 - 0.040	0.030 - 0.060
0.003 - 0.007	0.005 - 0.011	0.007 - 0.015	0.010 - 0.019	0.015 - 0.028	0.020 - 0.040	0.030 - 0.060
0.003 - 0.007	0.005 - 0.011	0.007 - 0.015	0.010 - 0.019	0.015 - 0.028	0.020 - 0.040	0.030 - 0.060
0.003 - 0.007	0.005 - 0.011	0.007 - 0.015	0.010 - 0.019	0.015 - 0.028	0.020 - 0.040	0.030 - 0.060
0.003 - 0.007	0.005 - 0.011	0.007 - 0.015	0.010 - 0.019	0.015 - 0.028	0.020 - 0.040	0.030 - 0.060
0.003 - 0.007	0.005 - 0.011	0.007 - 0.015	0.010 - 0.019	0.015 - 0.028	0.020 - 0.040	0.030 - 0.060
0.003 - 0.007	0.005 - 0.011	0.007 - 0.015	0.010 - 0.019	0.015 - 0.028	0.020 - 0.040	0.030 - 0.060
0.003 - 0.007	0.005 - 0.011	0.007 - 0.015	0.010 - 0.019	0.015 - 0.028	0.020 - 0.040	0.030 - 0.060
0.003 - 0.007	0.005 - 0.011	0.007 - 0.015	0.010 - 0.019	0.015 - 0.028	0.020 - 0.040	0.030 - 0.060
0.003 - 0.007	0.005 - 0.011	0.007 - 0.015	0.010 - 0.019	0.015 - 0.028	0.020 - 0.040	0.030 - 0.060
0.003 - 0.007	0.005 - 0.011	0.007 - 0.015	0.010 - 0.019	0.015 - 0.028	0.020 - 0.040	0.030 - 0.060
0.003 - 0.007	0.005 - 0.011	0.007 - 0.015	0.010 - 0.019	0.015 - 0.028	0.020 - 0.040	0.030 - 0.060
0.003 - 0.007	0.005 - 0.011	0.007 - 0.015	0.010 - 0.019	0.015 - 0.028	0.020 - 0.040	0.030 - 0.060
0.003 - 0.007	0.005 - 0.011	0.007 - 0.015	0.010 - 0.019	0.015 - 0.028	0.020 - 0.040	0.030 - 0.060
0.003 - 0.007	0.005 - 0.011	0.007 - 0.015	0.010 - 0.019	0.015 - 0.028	0.020 - 0.040	0.030 - 0.060





FILETAGE



GEWINDEN













THREADING



FILETTATURA









MENET

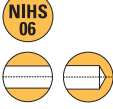

	SÉLECTION DES OUTILS À FILETER	278
	MICRO-TARAUDS COUPANTS	286
	MICRO-TARAUDS À REFOULER	289
	JAUGES FILETÉES	291
	OUTILS À TOURBILLONNER	293
	TOURBILLONNEURS-PERCEURS	299
	FILETAGE AUTOFREIN	301
	FRAISES À POLYGONER	304
	FRAISES À FILETER	305
	INFORMATIONS	315
	CONDITIONS DE COUPE	320

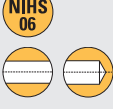
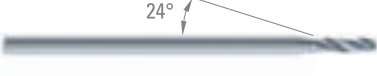
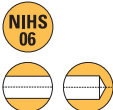
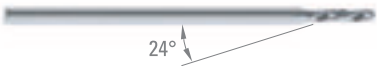
SÉLECTION DES OUTILS À FILETER





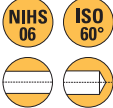

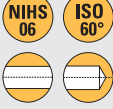





✓ = article de stock

		Z	Page		<input type="checkbox"/> CARBURE	<input checked="" type="checkbox"/> DI-TOP				
MICRO-TARAUDS COUPANTS										
DIXI 1712 R S 0.30 - M 2.00		3	286		<input checked="" type="checkbox"/>					
DIXI 1712 L S 0.60 - S 1.00		3	286		<input checked="" type="checkbox"/>					
DIXI 1713 S 0.40 - S 1.40		3	287		<input checked="" type="checkbox"/>					
DIXI 1708 S 0.30 - S 1.40		3	287		<input checked="" type="checkbox"/>	<input checked="" type="checkbox"/>				
DIXI 1710 S 0.30 - S 1.40		3	288		<input checked="" type="checkbox"/>					

MICRO-TARAUDS À REFOULER

DIXI 1715 S 0.40 - S 1.40 M 1.00 - M 2.20		-	289			<input checked="" type="checkbox"/>				
DIXI 1716 S 0.40 - S 1.40 M 1.00 - M 1.40		-	290			<input checked="" type="checkbox"/>				

JAUGES FILETÉES

DIXI 1718-NT R+L R S 0.30 - S 1.40 L S 0.50 - S 1.20		-	291		<input checked="" type="checkbox"/>					
DIXI 1718-RT S 0.30 - S 1.40		-	291		<input checked="" type="checkbox"/>					
DIXI 1719-NT/RT R+L R S 0.30 - S 1.40 L S 0.50 - S 1.20		-	291		<input checked="" type="checkbox"/>					
DIXI 1718-M M 1.00 - M 3.00		-	292		<input checked="" type="checkbox"/>					
DIXI 1719-M M 1.00 - M 3.00		-	292		<input checked="" type="checkbox"/>					
SET DE JAUGES		-	293		<input checked="" type="checkbox"/>					

○ bien ⊙ excellent

Acier + Pb	Acier faibl. allié	Aciers fort. allié	Acier inox aust.	Aciers Fontes 45-65 HRC	Fontes	Super alliages Ni / Co	Titane, alliages de titane	Alliage Cu Argent Or	Alliage Cu difficile	Alu	Graphite	Plastique
------------	--------------------	--------------------	------------------	-------------------------	--------	------------------------	----------------------------	----------------------	----------------------	-----	----------	-----------

○								⊙				
○								⊙				
⊙								○	○	○		
○								⊙	○			
○								⊙	○			

○	⊙	○	⊙					○	○	○		
○								⊙	⊙	⊙		

SÉLECTION DES OUTILS À FILETER

✓ = article de stock

		Z	Page		<input type="checkbox"/> CARBURE	<input checked="" type="checkbox"/> TiAIN	<input checked="" type="checkbox"/> CUTINOX	<input checked="" type="checkbox"/> DI-TOP	<input checked="" type="checkbox"/> DAC
DIXI 1739 S 0.30 - S 1.40 Profil partiel		1	293		✓				
DIXI 1738 S 0.70 - M 3.00 Profil partiel		3	294		✓		✓		
DIXI 1730 M 0.80 - M 10.00		3 - 6	295		✓	✓			
DIXI 1731 M 0.80 - M 10.00		3 - 6	296		✓	✓			
DIXI 1735 UNF N°1 - UNC 1/2"		3 - 6	297		✓	✓			
DIXI 1736 UNF N°1 - UNC 1/2"		3 - 6	298		✓	✓			

TOURBILLONNEURS-PERCEURS

DIXI 1740 S 0.80 - M 10.00		1 - 3	299		✓		✓		
DIXI 1742 M 5.00 - M 10.00		2	300						✓
DIXI 1744 M 5.00 - M 10.00		4	300				✓		

FILETAGE AUTOFREIN

DIXI 1712-AF/BT S 0.70 - M 1.40		3	301		✓				
DIXI 1716-AF/BT S 0.70 - M 1.40		-	301					✓	
DIXI 1738-AF/BT S 0.70 - M 3.00 Profil partiel		3	302		✓				
DIXI 1740-AF/BT S 0.80 - M 3.00		1 - 2	302		✓				

○ bien ⊙ excellent

Acier + Pb	Acier faibl. allié	Aciers fort. allié	Acier inox aust.	Aciers Fontes 45-65 HRC	Fontes	Super alliages Ni / Co	Titane, alliages de titane	Alliage Cu Argent Or	Alliage Cu difficile	Alu	Graphite	Plastique
------------	--------------------	--------------------	------------------	-------------------------	--------	------------------------	----------------------------	----------------------	----------------------	-----	----------	-----------





⊙	○	○	○				⊙	⊙	⊙	○		○
		⊙	⊙			○	⊙					
○	⊙	⊙	⊙		○	⊙	⊙	○	○	○	○	○
○	⊙	⊙	⊙		○	⊙	⊙	○	○	○	○	○
○	⊙	⊙	⊙		○	⊙	⊙	○	○	○	○	○
○	⊙	⊙	⊙		○	⊙	⊙	○	○	○	○	○

○	○	○	○		⊙	○	⊙	⊙	⊙	⊙	○	⊙
								⊙	⊙	⊙	○	⊙
○	⊙	⊙	⊙		⊙	⊙	⊙					



○								⊙				
○								⊙	⊙	⊙		
○	⊙	⊙	⊙			○	⊙	○	○	○		○
○	○	○	○		⊙	○	⊙	⊙	⊙	⊙	○	⊙

SÉLECTION DES OUTILS À FILETER

✓ = article de stock

FILETAGE AUTOFREIN	Z	Page		<input type="checkbox"/> CARBURE	<input checked="" type="checkbox"/> TITAIN	<input checked="" type="checkbox"/> CUTINOX			
DIXI 1718-AF/BT S 0.70 - M 3.00 	-	303		✓					
DIXI 1719-AF/BT S 0.70 - M 3.00 	-	303		✓					

FRAISES À FILETER PAR POLYGONAGE

DIXI 1660 S 0.40 - S 1.40 	94	304		✓					
---	----	-----	---	---	--	--	--	--	--

FRAISES À FILETER

DIXI 7910 M 1.4 - M 24.0 	2 - 4	305		✓	✓				
DIXI 7908 M 2.0 - M 24.0 	3 - 6	306		✓	✓				
DIXI 7913 M 10 - M 30 	4 - 5	307	 	✓		✓			
DIXI 7920 UNC N°2 - UNC 3/4" 	2 - 4	308		✓	✓				
DIXI 7918 UNF N°2 - UNC 3/4" 	3 - 5	309		✓	✓				
DIXI 7923 UNJF N°10 - UNJF 1/2" 	3 - 4	310	 	✓					
DIXI 7940 G1/16" - G1" 	3 - 4	310		✓					
DIXI 7946 R1/16" - R2-1/2" 	3 - 4	311		✓					
DIXI 7950 NPT 1/16" - NPT 2" 	3 - 4	311		✓					
DIXI 7956 NPTF 1/16" - NPTF 2" 	3 - 4	312		✓					

○ bien ⊙ excellent

Acier + Pb	Acier faibl. allié	Aciers fort. allié	Acier inox aust.	Aciers Fontes 45-65 HRC	Fontes	Super alliages Ni / Co	Titane, alliages de titane	Alliage Cu Argent Or	Alliage Cu difficile	Alu	Graphite	Plastique
------------	--------------------	--------------------	------------------	-------------------------	--------	------------------------	----------------------------	----------------------	----------------------	-----	----------	-----------

⊙	⊙	⊙	⊙				○	⊙	⊙			
---	---	---	---	--	--	--	---	---	---	--	--	--

⊙	○	○	○		⊙		○	⊙	⊙	⊙		⊙
⊙	○	○	○		⊙		○	⊙	⊙	⊙		⊙
⊙	○	○	○		⊙		○	⊙	⊙	⊙		⊙
⊙	○	○	○		⊙		○	⊙	⊙	⊙		⊙
⊙	○	○	○		⊙		○	⊙	⊙	⊙		⊙
⊙	○	○	○		⊙		○	⊙	⊙	⊙		⊙
⊙	○	○	○		⊙		○	⊙	⊙	⊙		⊙
⊙	○	○	○		⊙		○	⊙	⊙	⊙		⊙
⊙	○	○	○		⊙		○	⊙	⊙	⊙		⊙
⊙	○	○	○		⊙		○	⊙	⊙	⊙		⊙
⊙	○	○	○		⊙		○	⊙	⊙	⊙		⊙

SÉLECTION DES OUTILS À FILETER

✓ = article de stock

		Z	Page		<input type="checkbox"/> CARBURE	<input type="checkbox"/> CUTINOX			
FRAISES À FILETER ET CHANFREINER									
DIXI 7915 M 4.0 - M 16.0		3 - 4	312		✓	✓			
DIXI 7925 UNC N°8 - UNC 5/8"		3 - 4	313		✓	✓			
FRAISES À PERCER, FILETER ET CHANFREINER									
DIXI 7985 M 4.0 - M 16.0		2	314		✓	✓			



○ bien ⊙ excellent

Acier + Pb	Acier faibl. allié	Aciers fort. allié	Acier inox aust.	Aciers Fontes 45-65 HRC	Fontes	Super alliages Ni / Co	Titane, alliages de titane	Alliage Cu Argent Or	Alliage Cu difficile	Alu	Graphite	Plastique
⊙	○	○	○		⊙		○	⊙	⊙	⊙		⊙
⊙	○	○	○		⊙		○	⊙	⊙	⊙		⊙
					⊙			⊙	⊙	⊙		



DIXI 1712 R

MICRO-TARAUDS COUPANTS

Z = 3



P. 315
P. 318

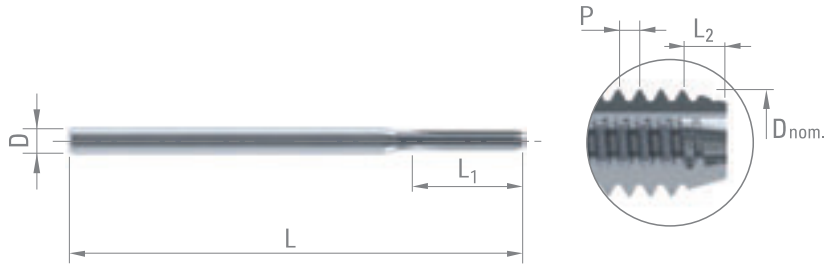
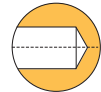
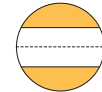

Acier
+ Pb

Alliage Cu
Argent
Or

D nom.	Pas	Ø perç. laiton	Ø perç. acier	L ₁	L ₂	D _{h5}	L	NIHS-3G CARBURE	NIHS-3G+ CARBURE	ISO2-6H CARBURE
S 0.30	0.08	0.23	0.24	1.0	0.25	1.5	30	62326		
S 0.35	0.09	0.27	0.28	1.5	0.27	1.5	30	965342		
S 0.40	0.10	0.32	0.33	2.0	0.30	1.5	30	62327	62328	
S 0.50	0.125	0.40	0.42	2.5	0.38	1.5	30	62329	62330	
S 0.60	0.15	0.48	0.50	3.0	0.45	1.5	30	62331	62332	
S 0.70	0.175	0.56	0.58	3.0	0.52	1.5	30	62334	62335	
S 0.80	0.20	0.64	0.66	3.5	0.60	1.5	30	62337	62338	
S 0.90	0.225	0.72	0.74	4.0	0.67	1.5	30	62342	62343	
S 1.00	0.25	0.80	0.82	4.0	0.76	1.5	30	62345	62346	
S 1.20	0.25	1.00	1.02	5.0	0.76	1.5	30	62348		
S 1.40	0.30	1.15	1.17	5.0	0.85	1.5	30	62351		
M 1.50	0.30	1.26	1.28	6.0	0.85	2.0	38			62353
M 2.00	0.40	1.65	1.68	11.0	1.00	2.5	43			62354

n Vitesse de rotation [tr/min]

500 - 2500

DIXI 1712 L

MICRO-TARAUDS COUPANTS
COUPE À GAUCHE

Z = 3



P. 315
P. 318

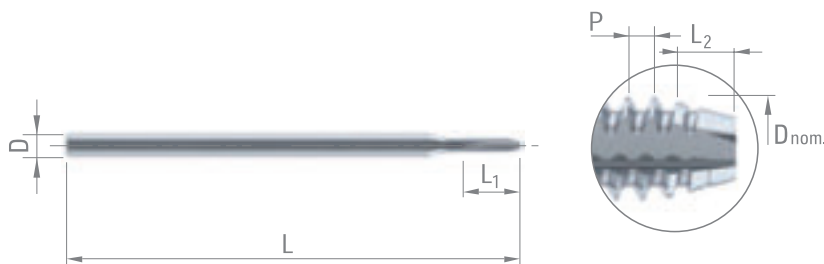
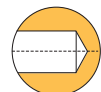
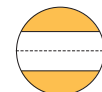

Acier
+ Pb

Alliage Cu
Argent
Or

D nom.	Pas	Ø perç. laiton	Ø perç. acier	L ₁	L ₂	D _{h5}	L	NIHS-3G CARBURE
S 0.60	0.15	0.49	0.51	4.0	0.45	1.5	30	969369
S 0.70	0.175	0.57	0.59	4.0	0.52	1.5	30	969370
S 0.80	0.20	0.65	0.67	4.0	0.60	1.5	30	969371
S 0.90	0.225	0.73	0.75	4.0	0.67	1.5	30	969372
S 1.00	0.25	0.81	0.83	4.0	0.75	1.5	30	969373

n Vitesse de rotation [tr/min]

500 - 2500



DIXI 1713

MICRO-TARAUDS COUPANTS
HAUTE PERFORMANCE

Z = 3

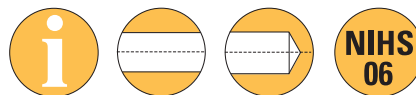

P. 315
P. 318

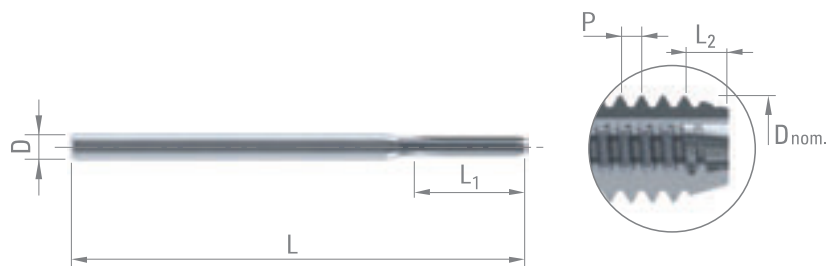
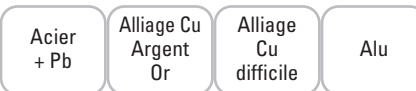

D nom.	Pas	Ø perç. laiton	Ø perç. acier	L ₁	L ₂	D _{h5}	L	NIHS-3G CARBURE
S 0.40	0.10	0.33	0.34	2.5	0.30	2.0	30	969795
S 0.50	0.125	0.41	0.43	3.5	0.38	2.0	30	969474
S 0.60	0.15	0.49	0.51	4.0	0.45	2.0	30	969497
S 0.70	0.175	0.57	0.59	4.0	0.52	2.0	30	969498
S 0.80	0.20	0.65	0.67	4.0	0.60	2.0	30	969499
S 0.90	0.225	0.73	0.75	4.0	0.67	2.0	30	969500
S 1.00	0.25	0.81	0.83	4.0	0.76	2.0	30	969501
S 1.20	0.25	1.01	1.03	5.0	0.76	2.0	30	969502
S 1.40	0.30	1.16	1.18	5.0	0.85	2.0	30	969503

n Vitesse de rotation [tr/min]

500 - 2500

DIXI 1708

MICRO-TARAUDS COUPANTS
HÉLICE À DROITE, COUPE À DROITE

Z = 3

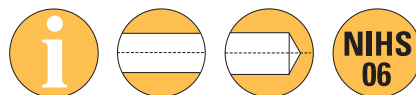

P. 315
P. 318

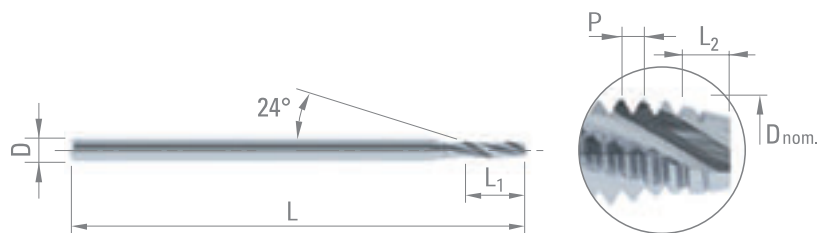

D nom.	Pas	Ø perç. laiton	Ø perç. acier	L ₁	L ₂	D _{h5}	L	NIHS-3G CARBURE	NIHS-3G DI-TOP
S 0.30	0.08	0.23	0.24	1.0	0.25	1.5	30	986881	303483
S 0.35	0.09	0.27	0.28	1.5	0.27	1.5	30	986882	303484
S 0.40	0.10	0.32	0.33	2.5	0.30	1.5	30	986883	303485
S 0.50	0.125	0.40	0.42	3.5	0.38	1.5	30	984405	303486
S 0.60	0.15	0.48	0.50	4.0	0.45	1.5	30	983633	303487
S 0.70	0.175	0.56	0.58	4.0	0.52	1.5	30	986884	303488
S 0.80	0.20	0.64	0.66	4.0	0.60	1.5	30	986885	303489
S 0.90	0.225	0.72	0.74	4.0	0.67	1.5	30	986886	303490
S 1.00	0.25	0.80	0.82	4.0	0.76	1.5	30	986887	303491
S 1.20	0.25	1.00	1.02	5.0	0.76	1.5	30	986888	303492
S 1.40	0.30	1.15	1.17	5.0	0.85	1.5	30	986889	303493

n Vitesse de rotation [tr/min]

500 - 2500



DIXI 1710

MICRO-TARAUDS COUPANTS
HÉLICE À GAUCHE, COUPE À DROITE

Z = 3



P. 315
P. 318

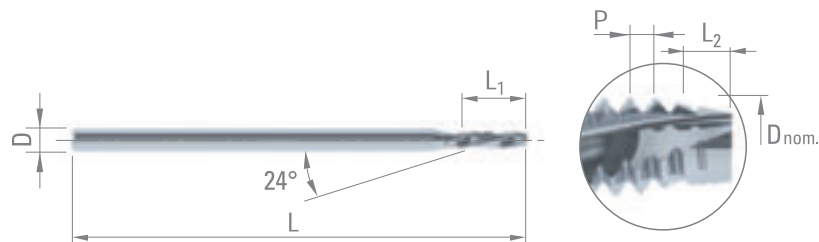

Acier de
décolletage

Alliage Cu
Argent
Or

Alliage
Cu
difficile

D nom.	Pas	Ø perç. laiton	Ø perç. acier	L ₁	L ₂	D _{h5}	L	NIHS-3G CARBURE
S 0.30	0.08	0.23	0.24	1.0	0.25	1.5	30	986890
S 0.35	0.09	0.27	0.28	1.5	0.27	1.5	30	986891
S 0.40	0.10	0.32	0.33	2.5	0.30	1.5	30	986892
S 0.50	0.125	0.40	0.42	3.5	0.38	1.5	30	986893
S 0.60	0.15	0.48	0.50	4.0	0.45	1.5	30	986894
S 0.70	0.175	0.56	0.58	4.0	0.52	1.5	30	986895
S 0.80	0.20	0.64	0.66	4.0	0.60	1.5	30	986896
S 0.90	0.225	0.72	0.74	4.0	0.67	1.5	30	986897
S 1.00	0.25	0.80	0.82	4.0	0.76	1.5	30	986898
S 1.20	0.25	1.00	1.02	5.0	0.76	1.5	30	986899
S 1.40	0.30	1.15	1.17	5.0	0.85	1.5	30	986900

n Vitesse de rotation [tr/min]

500 - 2500



DIXI 1715 DI-TOP

MICRO-TARAUDS À REFOULER

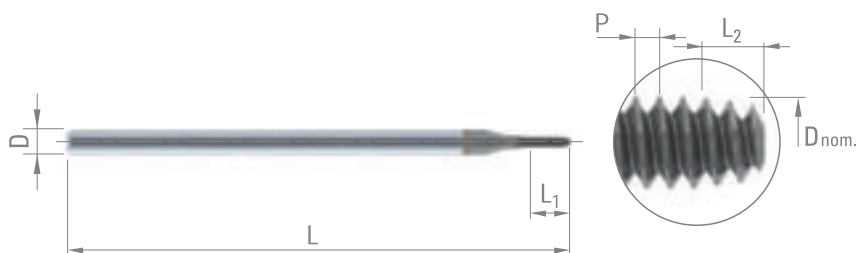

P. 315
P. 318

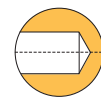
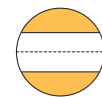

Acier
+ Pb

Acier
faibl.
allié

Acier
fort.
allié

Acier
inox
aust.

Alliage Cu
Argent
Or

Alliage
Cu
difficile

Alu

D nom.	Pas	Ø perç. laiton	Ø perç. acier	L ₁	L ₂	D _{h5}	L	NIHS-3GX DI-TOP
S 0.40	0.10	0.36 - 0.37	0.37 - 0.38	1.6	0.30	1.5	30	974654
S 0.50	0.125	0.45 - 0.46	0.46 - 0.47	2.0	0.37	1.5	30	972407
S 0.60	0.15	0.54 - 0.55	0.55 - 0.56	2.4	0.45	1.5	30	970899
S 0.70	0.175	0.62 - 0.63	0.63 - 0.64	2.8	0.52	1.5	30	970900
S 0.80	0.20	0.70 - 0.71	0.71 - 0.72	3.2	0.60	1.5	30	970901
S 0.90	0.225	0.81 - 0.82	0.82 - 0.83	3.6	0.67	1.5	30	970902
S 1.00	0.25	0.89 - 0.90	0.90 - 0.91	4.0	0.75	1.5	30	305793
S 1.20	0.20	1.11 - 1.12	1.12 - 1.13	4.8	0.60	1.5	30	305794
S 1.20	0.25	1.08 - 1.09	1.09 - 1.10	4.8	0.75	1.5	30	305795
S 1.40	0.20	1.30 - 1.32	1.32 - 1.33	5.6	0.60	1.5	30	305796
S 1.40	0.30	1.27 - 1.28	1.28 - 1.29	5.6	0.90	1.5	30	305797

D nom.	Pas	Ø perç. laiton	Ø perç. acier	L ₁	L ₂	D _{h5}	L	4HX DI-TOP	5HX DI-TOP	6HX DI-TOP
M 1.00	0.25	0.89 - 0.90	0.90 - 0.91	4.0	0.75	1.5	30		970903	
M 1.20	0.20	1.11 - 1.12	1.12 - 1.13	4.8	0.60	1.5	30	978772		
M 1.20	0.25	1.09 - 1.10	1.10 - 1.11	4.8	0.75	1.5	30		970904	
M 1.40	0.20	1.31 - 1.32	1.32 - 1.33	5.6	0.60	1.5	30	973645		
M 1.40	0.30	1.27 - 1.28	1.28 - 1.29	5.6	0.90	1.5	38		970905	
M 1.50	0.30	1.37 - 1.38	1.38 - 1.39	6.0	0.90	2.0	38			971650
M 1.60	0.35	1.45 - 1.46	1.46 - 1.47	6.0	1.05	2.0	38			970906
M 1.80	0.20	1.71 - 1.72	1.72 - 1.73	7.0	0.60	2.0	38	975090		
M 2.00	0.20	1.91 - 1.92	1.92 - 1.93	8.0	0.60	2.5	43	976259		
M 2.00	0.40	1.83 - 1.84	1.83 - 1.84	8.0	1.20	2.5	43			970907
M 2.20	0.25	2.09 - 2.10	2.10 - 2.11	8.0	0.75	2.5	43		974959	

n Vitesse de rotation [tr/min]

500 - 2500

DIXI 1716 DI-TOP

MICRO-TARAUDS À REFOULER



P. 315
P. 318

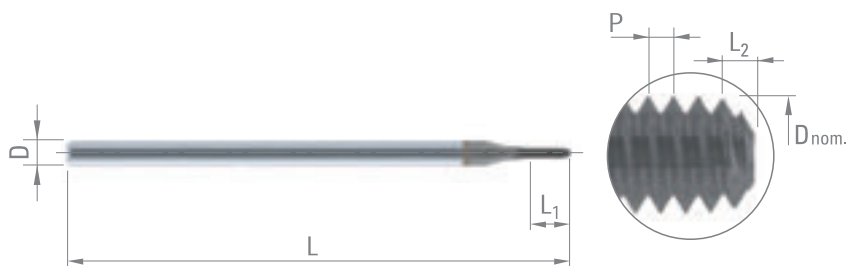

Acier + Pb	Alliage Cu Argent Or	Alliage Cu difficile	Alu
------------	----------------------	----------------------	-----

D nom.	Pas	Ø perç. laiton	Ø perç. acier	L ₁	L ₂	D _{h5}	L	NIHS-3GX DI-TOP
S 0.40	0.10	0.36 - 0.37	0.37 - 0.38	1.6	0.20	1.5	30	992498
S 0.50	0.125	0.45 - 0.46	0.46 - 0.47	2.0	0.25	1.5	30	992509
S 0.60	0.15	0.54 - 0.55	0.55 - 0.56	2.4	0.30	1.5	30	992514
S 0.70	0.175	0.62 - 0.63	0.63 - 0.64	2.8	0.35	1.5	30	992515
S 0.80	0.20	0.70 - 0.71	0.71 - 0.72	3.2	0.40	1.5	30	992516
S 0.90	0.225	0.81 - 0.82	0.82 - 0.83	3.6	0.45	1.5	30	992517
S 1.00	0.25	0.89 - 0.90	0.90 - 0.91	4.0	0.50	1.5	30	305799
S 1.20	0.20	1.11 - 1.12	1.12 - 1.13	4.8	0.40	1.5	30	305800
S 1.20	0.25	1.08 - 1.09	1.09 - 1.10	4.8	0.50	1.5	30	305801
S 1.40	0.20	1.31 - 1.32	1.32 - 1.33	5.6	0.40	1.5	30	305802
S 1.40	0.30	1.27 - 1.28	1.28 - 1.29	5.6	0.60	1.5	30	305804

D nom.	Pas	Ø perç. laiton	Ø perç. acier	L ₁	L ₂	D _{h5}	L	4HX DI-TOP	5HX DI-TOP
M 1.00	0.25	0.89 - 0.90	0.90 - 0.91	4.0	0.50	1.5	30		992518
M 1.20	0.20	1.11 - 1.12	1.12 - 1.13	4.8	0.40	1.5	30	992519	
M 1.20	0.25	1.08 - 1.09	1.09 - 1.10	4.8	0.50	1.5	30		992520
M 1.40	0.20	1.31 - 1.32	1.32 - 1.33	5.6	0.40	1.5	30	992521	
M 1.40	0.30	1.27 - 1.28	1.28 - 1.29	5.6	0.60	1.5	38		992522

n Vitesse de rotation [tr/min]

500 - 2500



DIXI 1718-NT, -RT - DIXI 1719-NT/RT

JAUGES FILETÉES NIHS
"GO" - "NO GO"



P. 316

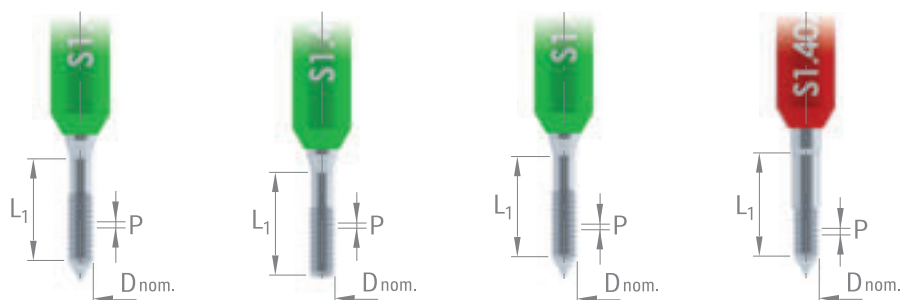

D nom.	Pas	L ₁	1718-NT GO	1718-NT (fond plat) GO	1718-RT GO	1719-NT/RT NO GO
S 0.30	0.08	1.0	965295	978958	983114	965312
S 0.35	0.09	1.3	965296	978959	983468	965313
S 0.40	0.10	2.0	965297	978960	983115	965314
S 0.50	0.125	2.5	965298	978961	983116	965315
S 0.60	0.15	3.0	965299	978962	983117	965316
S 0.70	0.175	3.0	965300	978963	983236	965317
S 0.80	0.20	3.5	965301	978964	983118	965318
S 0.90	0.225	4.0	965302	978965	983119	965319
S 1.00	0.25	4.0	965303	978966	983120	965320
S 1.20	0.25	5.0	965304	978967	983121	965321
S 1.40	0.30	5.0	965305	978968	983122	965322

Chaque jauge est livrée avec sa valeur de diamètre sur flancs

DIXI 1718-NT L - DIXI 1719-NT/RT L

JAUGES FILETÉES NIHS
"GO" - "NO GO"
POUR FILETAGE À GAUCHE



P. 316



D nom.	Pas	L ₁	1718-NT L GO	1719-NT/RT L NO GO
S 0.50	0.125	2.5	968369	968370
S 0.60	0.15	3.0	968345	968346
S 0.70	0.175	3.0	968344	968347
S 0.80	0.20	3.5	968343	968348
S 0.90	0.225	4.0	968925	968926
S 1.00	0.25	4.0	969395	969396
S 1.20	0.25	5.0	982638	982639

Chaque jauge est livrée avec sa valeur de diamètre sur flancs



DIXI 1718-M - DIXI 1719-M

JAUGES FILETÉES ISO
"GO" - "NO GO"

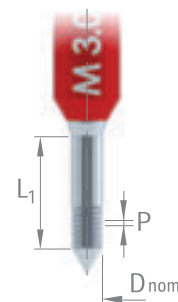
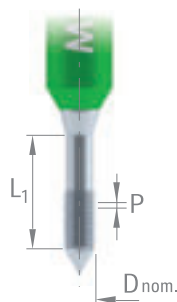

D nom.	Pas	L ₁	Tol.	1718-M GO	1719-M NO GO
M 1.00	0.25	5.0	5H	976633	976635
M 1.20	0.20	5.0	4H	305894	305900
M 1.20	0.20	5.0	5H	980934	980935
M 1.20	0.25	5.0	5H	976634	976636
M 1.40	0.20	5.0	4H	305895	305901
M 1.40	0.30	6.0	5H	976693	976710
M 1.50	0.30	6.0	6H	976694	976711
M 1.60	0.20	5.0	4H	305896	305902
M 1.60	0.20	5.0	5H	976695	976713
M 1.60	0.35	6.0	6H	975716	975717
M 1.80	0.20	5.0	4H	305897	305903
M 1.80	0.35	6.0	6H	976024	976026
M 2.00	0.20	5.0	4H	305898	305904
M 2.00	0.40	6.0	6H	976699	976716
M 2.20	0.20	5.0	4H	305899	305905
M 2.20	0.25	5.0	5H	976701	976718
M 2.20	0.45	8.0	6H	976702	976719
M 2.50	0.20	5.0	5H	976703	976720
M 2.50	0.25	5.0	5H	976706	976707
M 2.50	0.35	6.0	6H	303652	303653
M 2.50	0.45	8.0	6H	976704	976721
M 3.00	0.50	8.0	6H	976705	976722

Chaque jauge est livrée avec sa valeur de diamètre sur flancs



DIXI 1718 - SET

SET DE JAUGES FILETÉES NIHS
"GO" - "NO GO"



P. 316



Contenu	Art.
DIXI 1718-NT GO (S0.30-S1.40)	305989
DIXI 1719-NT/RT NO GO (S0.30-S1.40)	
DIXI 1718-RT GO (S0.30-S1.40)	305990
DIXI 1719-NT/RT NO GO (S0.30-S1.40)	
DIXI 1718-NT GO (S0.30-S1.40)	305991
DIXI 1718-RT GO (S0.30-S1.40)	
DIXI 1719-NT/RT NO GO (S0.30-S1.40)	



Composez votre propre sélection et personnalisez votre set de jauges.

NB: 2 x 11 emplacements ou 3 x 11 emplacements

DIXI 1739

OUTILS À TOURBILLONNER
PROFIL PARTIEL

Z = 1



P. 318



P. 320

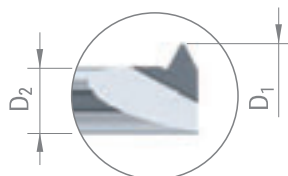

Acier + Pb	Acier faibl. allié	Acier fort. allié	Acier inox aust.	Titane, alliage de titane
Alliage Cu Argent Or	Alliage Cu difficile	Alu	Plastique	

D nom.	Pas	Ø perçage	D ₁	L ₁	D ₂	D _{h5}	L	CARBURE
S 0.30	0.08	0.23	0.22	0.70	0.13	3	38	961147
S 0.35	0.09	0.27	0.25	0.90	0.15	3	38	984299
S 0.40	0.10	0.32	0.30	0.90	0.19	3	38	961149
S 0.50	0.125	0.40	0.38	1.20	0.24	3	38	961163
S 0.60	0.15	0.48	0.46	1.50	0.29	3	38	961164
S 0.70	0.175	0.56	0.54	1.80	0.34	3	38	961165
S 0.80	0.20	0.64	0.60	2.00	0.37	3	38	961166
S 0.90	0.225	0.72	0.68	2.20	0.42	3	38	961167
S 1.00	0.25	0.80	0.76	2.40	0.48	3	38	961168
S 1.20	0.25	1.00	0.94	3.00	0.66	3	38	961169
S 1.40	0.30	1.15	1.10	3.30	0.76	3	38	961170



DIXI 1738

OUTILS À TOURBILLONNER PROFIL PARTIEL

Z = 3



P. 318



P. 320



NIHS
06



ISO
60°

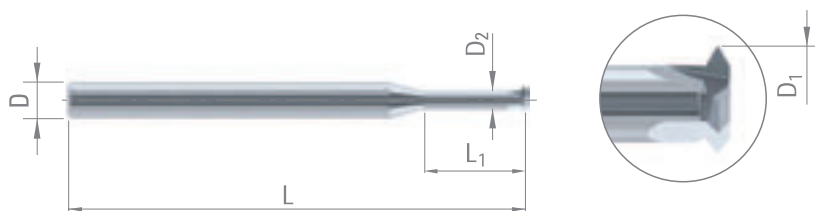

- Acier fort. allié
- Acier inox aust.
- Super alliages Ni / Co
- Titane, alliage de titane

D nom.		Pas	Ø perçage		D ₁	L ₁	D ₂	D _{h5}	L	CARBURE CUTINOX	
			ISO	NIHS							
	S 0.70	0.175		0.56	0.54	1.80	0.33	3	38	984319	985156
	S 0.80	0.20		0.64	0.62	2.30	0.38	3	38	965997	966008
	S 0.90	0.225		0.72	0.70	2.50	0.43	3	38	965996	966007
M 1.00	S 1.00	0.25	0.75	0.80	0.78	2.80	0.44	3	38	964485	966006
M 1.20	S 1.20	0.25	0.95	1.00	0.98	3.40	0.64	3	38	965664	965943
M 1.40	S 1.40	0.30	1.10	1.15	1.12	4.00	0.71	3	38	965988	965999
M 1.40		0.20	1.22		1.18	4.00	0.74	3	38	965989	965998
M 1.60		0.35	1.30		1.26	4.50	0.72	3	38	965990	966000
M 1.80		0.35 (0.20)	1.50 1.60		1.45	5.10	0.77	3	38	965991	966001
M 2.00		0.40 (0.20)	1.65 1.80		1.60	5.60	0.85	3	38	965992	966002
M 2.20		0.45 (0.25)	1.80 1.95		1.70	6.20	0.91	3	38	965993	966003
M 2.50		0.45 (0.35) (0.25) (0.20)	2.10 2.15 2.25 2.30		2.00	7.00	1.20	3	38	965994	966004
M 3.00		0.50 (0.35) (0.25) (0.20)	2.50 2.65 2.75 2.80		2.40	8.40	1.60	3	38	965995	966005

Un seul outil pour usiner plusieurs pas (exemple, de 0.20 à 0.50)

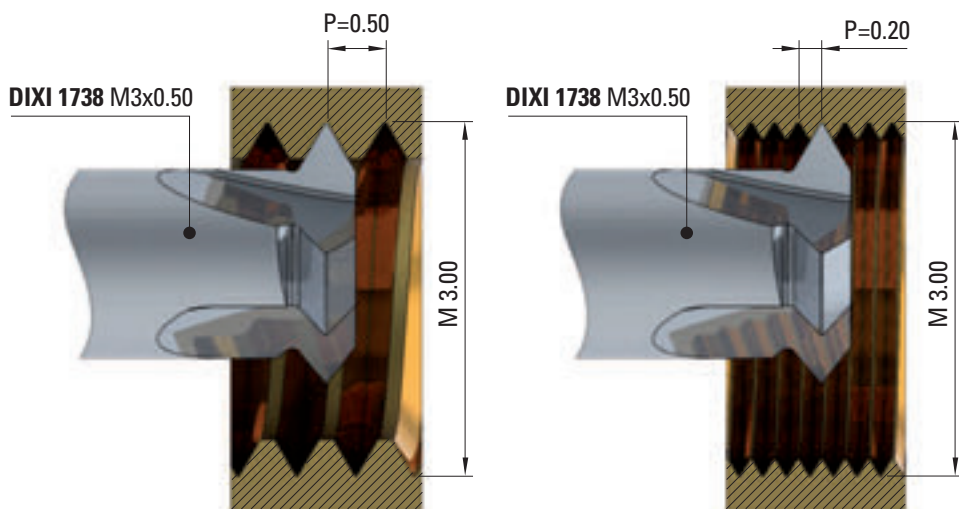

OUTILS À TOURBILLONNER PROFIL COMPLET

Z = 3-6



P. 318



P. 320



$$L_1 = 2 \times \emptyset \text{ nom.}$$

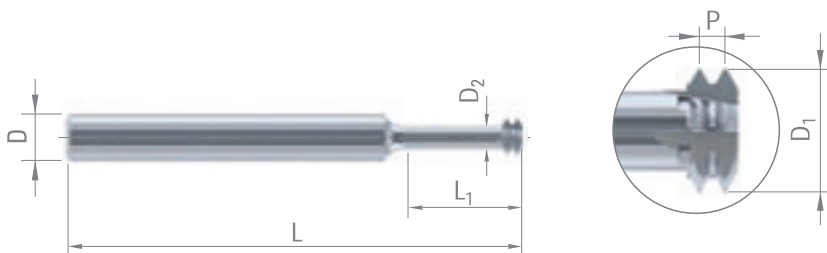

Acier + Pb	Acier faibl. allié	Acier fort. allié	Acier inox aust.	Fontes
Super alliages Ni / Co	Titane, alliage de titane	Alliage Cu Argent Or	Alliage Cu difficile	Alu
Graphite	Plastique			

D nom.	Pas	D ₁	L ₁	D ₂	D _{h5}	L	Z	CARBURE	TIAIN
M 0.80	0.20	0.60	1.85	0.27	3	38	3	958853	960446
M 0.90	0.225	0.66	2.10	0.33	3	38	3	953216	960117
M 1.00	0.25	0.73	2.30	0.34	3	38	3	953217	960118
M 1.20	0.25	0.92	2.80	0.53	3	38	3	953218	960450
M 1.40	0.30	1.05	3.20	0.60	3	38	3	953219	960451
M 1.60	0.35	1.21	3.70	0.69	3	38	3	953220	960453
M 1.80	0.20	1.41	4.10	0.89	3	38	3	961128	961130
M 1.80	0.35	1.41	4.10	0.89	3	38	3	953221	960454
M 2.00	0.40	1.55	4.60	0.96	3	38	3	953222	960455
M 2.20	0.20	1.72	5.10	1.08	3	38	3	961129	961132
M 2.20	0.45	1.72	5.10	1.08	3	38	3	953223	960456
M 2.50	0.25	2.00	5.80	1.35	3	38	3	960062	960459
M 2.50	0.35	2.00	5.80	1.35	3	38	3	960063	960460
M 2.50	0.45	2.00	5.80	1.35	3	38	3	953225	960461
M 3.00	0.50	2.44	7.00	1.70	4	42	3	955698	960462
M 4.00	0.70	3.20	9.30	2.25	4	42	3	955699	960463
M 5.00	0.80	4.00	11.50	2.80	6	57	4	957925	960464
M 6.00	1.00	4.85	13.80	3.15	6	57	4	957982	960465
M 8.00	1.25	6.50	18.40	4.65	8	75	6	958039	960466
M 10.00	1.50	7.90	23.00	5.60	8	75	6	958040	960467



OUTILS À TOURBILLONNER PROFIL COMPLET

Z = 3-6



P. 318



P. 320



$L_1 = 3 \times \emptyset$ nom.

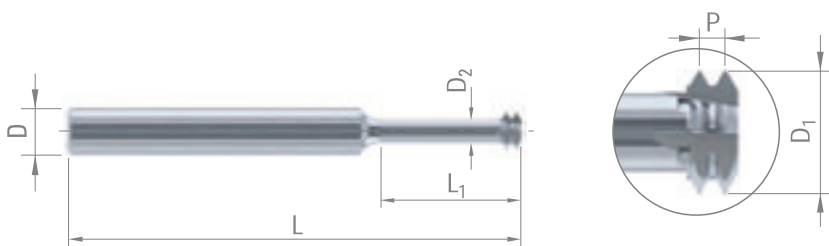

Acier + Pb	Acier faibl. allié	Acier fort. allié	Acier inox aust.	Fontes
Super alliages Ni / Co	Titane, alliage de titane	Alliage Cu Argent Or	Alliage Cu difficile	Alu
Graphite	Plastique			

D nom.	Pas	D ₁	L ₁	D ₂	D _{h5}	L	Z	CARBURE	TiAIN
M 0.80	0.20	0.60	2.60	0.27	3	38	3	961148	961176
M 0.90	0.225	0.66	2.90	0.33	3	38	3	961150	961177
M 1.00	0.25	0.73	3.20	0.34	3	38	3	961151	961178
M 1.20	0.25	0.92	3.85	0.53	3	38	3	961152	961179
M 1.40	0.30	1.05	4.50	0.60	3	38	3	961153	961180
M 1.60	0.35	1.21	5.10	0.69	3	38	3	961154	961181
M 1.80	0.20	1.41	5.80	0.89	3	38	3	961155	961182
M 1.80	0.35	1.41	5.80	0.89	3	38	3	961156	961183
M 2.00	0.40	1.55	6.40	0.96	3	38	3	961157	961184
M 2.20	0.20	1.72	7.10	1.08	3	38	3	961158	961185
M 2.20	0.45	1.72	7.10	1.08	3	38	3	961159	961186
M 2.50	0.25	2.00	8.00	1.35	3	38	3	961160	961187
M 2.50	0.35	2.00	8.00	1.35	3	38	3	961161	961188
M 2.50	0.45	2.00	8.00	1.35	3	38	3	961162	961189
M 3.00	0.50	2.44	9.60	1.70	4	42	3	961171	961190
M 4.00	0.70	3.20	12.80	2.25	4	42	3	961172	961191
M 5.00	0.80	4.00	16.00	2.80	6	57	4	961173	961192
M 6.00	1.00	4.85	19.20	3.15	6	57	4	961174	961193
M 8.00	1.25	6.50	25.60	4.65	8	75	6	961175	961194
M 10.00	1.50	7.90	32.00	5.60	8	75	6	960883	961195



OUTILS À TOURBILLONNER PROFIL COMPLET

Z = 3-6



P. 318



P. 320



$L_1 = 2 \times \varnothing \text{ nom.}$

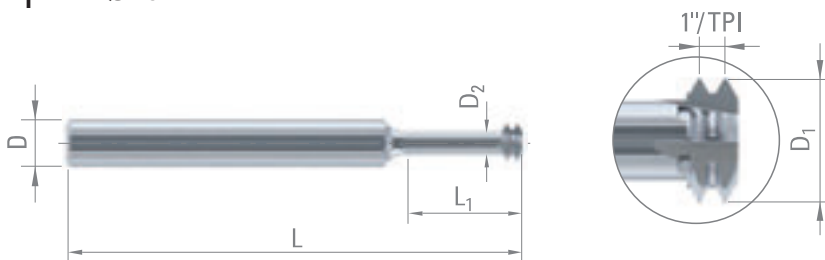

Acier + Pb	Acier faibl. allié	Acier fort. allié	Acier inox aust.	Fontes
Super alliages Ni / Co	Titane, alliage de titane	Alliage Cu Argent Or	Alliage Cu difficile	Alu
Graphite	Plastique			

UNC	UNF	UNEF	UN	TPI	D ₁	L ₁	D ₂	D _{h5}	L	Z	CARBURE	TiAIN
	N°1			72	1.40	4.3	0.85	3	38	3	966664	966833
N°1	N°2			64	1.40	4.3	0.80	3	38	3	966663	966834
N°2	N°3			56	1.65	5.0	0.95	3	38	3	966662	966835
N°3	N°4			48	1.90	5.8	1.10	3	38	3	966661	966836
	N°5			44	2.00	7.3	1.15	3	38	3	966660	966837
N°4				40	2.10	6.6	1.17	4	42	3	966659	966838
N°5	N°6			40	2.45	7.3	1.52	4	42	3	966658	966839
	N°8			36	3.30	9.6	2.15	4	42	3	966657	966841
N°6				32	2.55	8.1	1.30	4	42	3	960656	966840
N°8	N°10	N°12		32	3.10	9.6	1.90	4	55	3	960205	960628
	N°12		5/16"	28	4.20	12.6	2.85	6	63	3	966655	966842
	1/4"	7/16"	5/16"	28	5.00	14.6	3.55	6	63	4	966654	966843
N°10				24	3.40	11.1	1.90	4	55	3	960395	960629
N°12	5/16"			24	4.10	12.6	2.70	6	57	4	960396	960360
1/4"			5/16"	20	4.70	14.6	2.90	6	57	4	960397	960631
5/16"	9/16"			18	6.10	18.2	4.00	8	63	6	960398	960635
3/8"			7/16"	16	7.50	21.9	5.30	8	63	6	960399	960636
7/16"	7/8"			14	8.70	25.6	6.20	10	75	6	960400	960637
1/2"				13	10.00	29.2	7.30	12	75	6	960402	960638



OUTILS À TOURBILLONNER PROFIL COMPLET

Z = 3-6



P. 318



P. 320



$L_1 = 3 \times \varnothing$ nom.

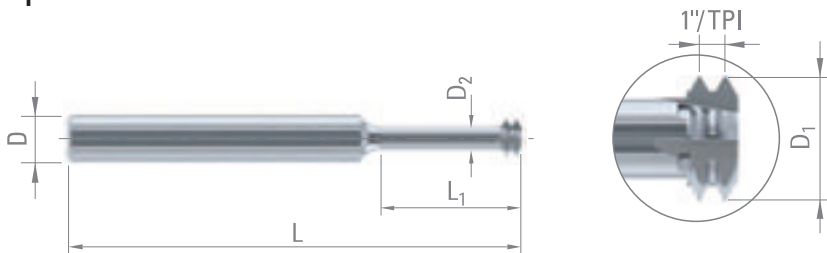

Acier + Pb	Acier faibl. allié	Acier fort. allié	Acier inox aust.	Fontes
Super alliages Ni / Co	Titane, alliage de titane	Alliage Cu Argent Or	Alliage Cu difficile	Alu
Graphite	Plastique			

UNC	UNF	UNEF	UN	TPI	D ₁	L ₁	D ₂	D _{h5}	L	Z	CARBURE	TiAIN
	N°1			72	1.40	6.0	0.85	3	38	3	96653	96652
N°1	N°2			64	1.40	6.0	0.80	3	38	3	96652	96651
N°2	N°3			56	1.65	7.0	0.95	3	38	3	96651	96650
N°3	N°4			48	1.90	8.1	1.10	3	38	3	96650	96649
	N°5			44	2.00	10.2	1.15	3	42	3	96649	96648
N°4				40	2.10	9.1	1.17	4	42	3	96648	96647
N°5	N°6			40	2.45	10.2	1.52	4	42	3	96647	96646
	N°8			36	3.30	13.4	2.15	4	42	3	96646	96645
N°6				32	2.55	11.3	1.30	4	42	3	96645	96644
N°8	N°10	N°12		32	3.10	13.4	1.90	4	55	3	961020	961062
	N°12	7/16''	5/16''	28	4.20	17.6	2.85	6	63	3	96644	96643
	1/4''	7/16''	5/16''	28	5.00	20.3	3.55	6	63	4	96641	96642
N°10				24	3.40	15.5	1.90	4	55	3	961052	961063
N°12	5/16''	9/16''		24	4.10	17.6	2.70	6	57	4	961053	961082
1/4''	1/2''		5/16''	20	4.70	20.3	2.90	6	63	4	961054	961085
5/16''	9/16''			18	6.10	25.4	4.00	8	75	6	961055	961086
3/8''	3/4''		7/16''	16	7.50	30.5	5.30	8	75	6	961056	961087
7/16''	7/8''			14	8.70	35.5	6.20	10	86	6	961057	961088
1/2''				13	10.00	40.6	7.30	12	93	6	961058	961060





P. 318



P. 322



ISO
60°

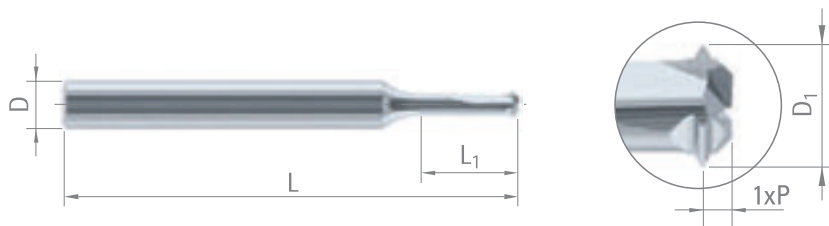

Acier + Pb	Acier faibl. allié	Acier fort. allié	Acier inox aust.	Fontes
Super alliages Ni / Co	Titane, alliage de titane	Alliage Cu Argent Or	Alliage Cu difficile	Alu
Graphite	Plastique			

D nom.	Pas	D ₁	L ₁	D _{h5}	L	Z	CARBURE CUTINOX	
S 0.80	0.20	0.60	2.4	3	38	1	977703	977716
S 0.90	0.225	0.66	2.7	3	38	1	977704	977717
M 1.00	0.20	0.80	3.0	3	38	1	985121	985134
M 1.00	0.25	0.73	3.0	3	38	1	977656	977698
M 1.20	0.20	1.00	3.6	3	38	1	985136	985143
M 1.20	0.25	0.92	3.6	3	38	1	977705	977718
M 1.40	0.20	1.20	4.2	3	38	1	985144	985145
M 1.40	0.30	1.05	4.2	3	38	1	977706	977719
M 1.60	0.35	1.21	4.8	3	38	1	977707	977720
M 2.00	0.40	1.55	6.0	3	38	2	977708	977721
M 2.50	0.45	2.00	7.5	3	38	2	977709	977722
M 3.00	0.50	2.44	9.0	6	57	2	977710	977723
M 4.00	0.70	3.20	12.0	6	57	2	977711	977724
M 5.00	0.80	4.00	15.0	6	57	2	977712	977725
M 6.00	1.00	4.85	18.0	6	57	3	977713	977726
M 8.00	1.25	6.50	24.0	8	75	3	977714	977727
M 10.00	1.50	7.90	30.0	8	75	3	977715	977728

Exemple pour usinage de matières difficiles (titane, acier inox).
Pour les matières faciles à usiner, l'opération n° 2 n'est pas nécessaire.

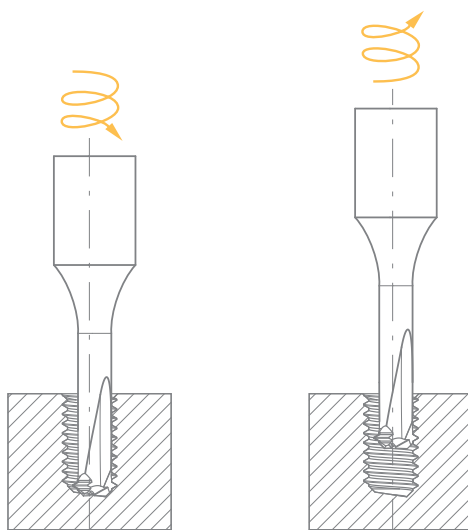

1

Plongée en spirale
au Ø d'ébauche
(Ø fini -2%)

2

Usinage au Ø fini
du filetage
en remontant



DIXI 1742

TOURBILLONNEURS-PERCEURS À TROU DE LUBRIFICATION

Z = 2



P. 318



P. 324

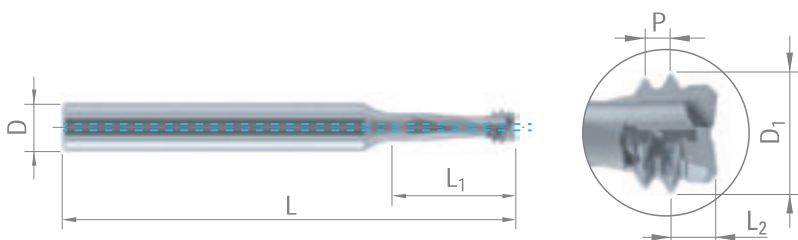

Alliage Cu Argent Or	Alliage Cu difficile	Alu	Graphite	Plastique
----------------------------	----------------------------	-----	----------	-----------

D nom.	Pas	D ₁	L ₁	L ₂	D _{h5}	L	DAC
M 5.00	0.80	4.00	12.5	1.50	8	75	303475
M 6.00	1.00	4.80	15.0	1.85	8	75	303476
M 8.00	1.25	6.40	20.0	2.30	8	75	303477
M 10.00	1.50	7.80	25.0	2.75	8	75	303478

DIXI 1744

TOURBILLONNEURS-PERCEURS À TROU DE LUBRIFICATION

Z = 4



P. 318



P. 324

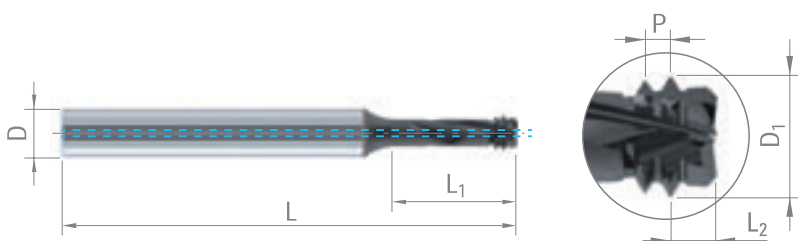

Acier + Pb	Acier faibl. allié	Acier fort. allié	Acier inox aust.	Fontes
Super alliages Ni / Co	Titane, alliage de titane			

D nom.	Pas	D ₁	L ₁	L ₂	D _{h5}	L	CUTINOX
M 5.00	0.80	4.00	12.5	1.50	8	75	303479
M 6.00	1.00	4.80	15.0	1.85	8	75	303480
M 8.00	1.25	6.40	20.0	2.30	8	75	303481
M 10.00	1.50	7.80	25.0	2.75	8	75	303482



DIXI 1712-AF/BT

MICRO-TARAUDS COUPANTS
PROFIL AUTOFREIN AF/BT

Z = 3



P. 317

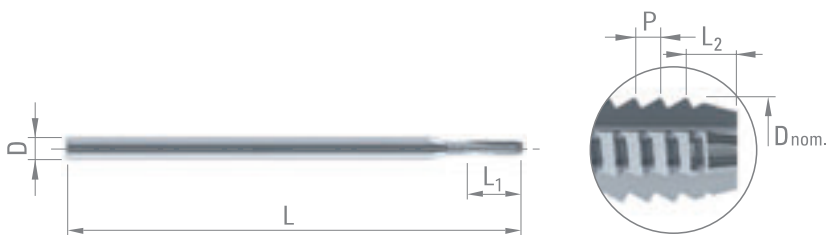

Acier
+ Pb

Alliage Cu
Argent
Or

D nom.	Pas	Ø perç.	L ₁	L ₂	D _{h5}	L	CARBURE
S 0.70	0.175	0.59	3.0	0.35	1.5	30	995574
S 0.80	0.20	0.68	3.5	0.40	1.5	30	995676
S 0.90	0.225	0.76	4.0	0.45	1.5	30	995677
M 1.00	0.25	0.84	4.0	0.50	1.5	30	995678
M 1.20	0.25	1.04	5.0	0.50	1.5	30	995679
M 1.40	0.30	1.21	5.0	0.60	1.5	30	995680

n Vitesse de rotation [tr/min]

500 - 2500

DIXI 1716-AF/BT

MICRO-TARAUDS À REFOULER
PROFIL AUTOFREIN AF/BT



P. 317

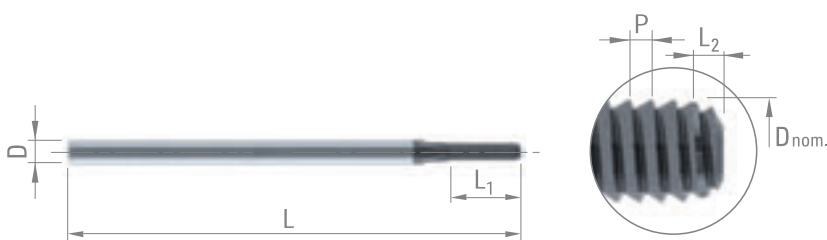

Acier
+ Pb

Alliage Cu
Argent
Or

Alliage
Cu
difficile

Alu

D nom.	Pas	Ø perç.	L ₁	L ₂	D _{h5}	L	DI-TOP
S 0.70	0.175	0.65	2.8	0.35	1.5	30	995723
S 0.80	0.20	0.74	3.2	0.40	1.5	30	995745
S 0.90	0.225	0.83	3.6	0.45	1.5	30	995746
M 1.00	0.25	0.92	4.0	0.50	1.5	30	995747
M 1.20	0.25	1.12	4.8	0.50	1.5	30	995748
M 1.40	0.30	1.31	5.6	0.60	1.0	30	995749

n Vitesse de rotation [tr/min]

500 - 2500



DIXI 1738-AF/BT

OUTILS À TOURBILLONNER
PROFIL PARTIEL
PROFIL AUTOFREIN AF/BT

Z = 3



P. 317



P. 320

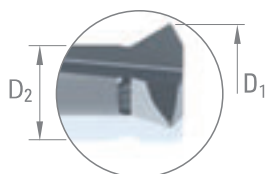
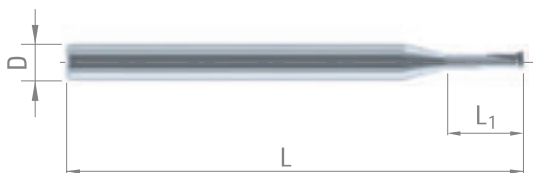

Acier + Pb	Acier faibl. allié	Acier fort. allié	Acier inox aust.	Super alliages Ni / Co
Titane, alliage de titane	Alliage Cu Argent Or	Alliage Cu difficile	Alu	Plastique

D nom.	Pas	Ø perç.	D ₁	L ₁	D ₂	D _{h5}	L	CARBURE
S 0.70	0.175	0.59	0.54	1.8	0.34	3	38	995725
S 0.80	0.20	0.68	0.62	2.3	0.39	3	38	995880
S 0.90	0.225	0.76	0.70	2.5	0.44	3	38	995881
M 1.00	0.25	0.84	0.80	2.8	0.51	3	38	995882
M 1.20	0.25	1.04	0.98	3.4	0.69	3	38	995883
M 1.40	0.30	1.21	1.12	4.0	0.77	3	38	995884
M 1.60	0.35	1.38	1.26	4.5	0.86	3	38	995885
M 2.00	0.40	1.75	1.60	5.6	1.14	3	38	995886
M 2.20	0.45	1.91	1.70	6.2	1.18	3	38	995887
M 3.00	0.50	2.68	2.40	8.4	1.82	3	38	995888

DIXI 1740-AF/BT

TOURBILLONNEURS-PERCEURS
PROFIL AUTOFREIN AF/BT

Z = 1-2



P. 317



P. 322

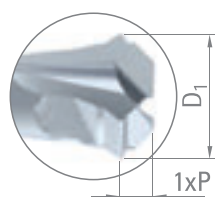

Acier + Pb	Acier faibl. allié	Aciers fort. allié	Acier inox aust.	Fontes
Super alliages Ni / Co	Titane, alliage de titane	Alliage Cu Argent Or	Alliage Cu difficile	Alu
Graphite	Plastique			

D nom.	Pas	D ₁	L ₁	D _{h5}	L	Z	CARBURE
S 0.80	0.20	0.60	2.4	3	38	1	300295
S 0.90	0.225	0.66	2.7	3	38	1	300435
M 1.00	0.25	0.73	3.0	3	38	1	300436
M 1.20	0.25	0.92	3.6	3	38	1	300437
M 1.40	0.30	1.05	4.2	3	38	1	300438
M 1.60	0.35	1.21	4.8	3	38	1	300439
M 2.00	0.40	1.55	6.0	3	38	2	300440
M 2.20	0.45	1.70	6.6	3	38	2	300441
M 2.50	0.45	2.00	7.5	3	38	2	300444
M 3.00	0.50	2.44	9.0	6	57	2	300445



DIXI 1718-AF/BT - DIXI 1719-AF/BT

JAUGES FILETÉES
 "GO" - "NO GO"
 PROFIL AUTOFREIN AF/BT



P. 317

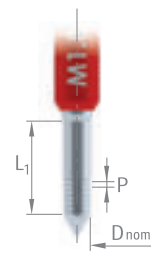
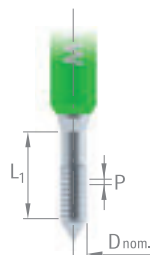

D nom.	Pas	L ₁	1718-AF/BT GO	1719-AF/BT NO GO
S 0.70	0.175	3.0	995572	995573
S 0.80	0.20	3.5	995615	995664
S 0.90	0.225	4.0	995616	995665
M 1.00	0.25	4.0	995617	995666
M 1.20	0.25	5.0	995619	995667
M 1.40	0.30	5.0	995620	995668
M 1.60	0.35	6.0	995621	995669
M 1.80	0.35	6.0	995622	995670
M 2.00	0.40	6.0	995623	995671
M 2.20	0.45	8.0	995624	995672
M 2.50	0.45	8.0	995631	995674
M 3.00	0.50	8.0	995626	995675



FRAISES À FILETER PAR POLYAGONAGE POUR VIS HORLOGÈRES NIHS

Z = 94

NIHS
06

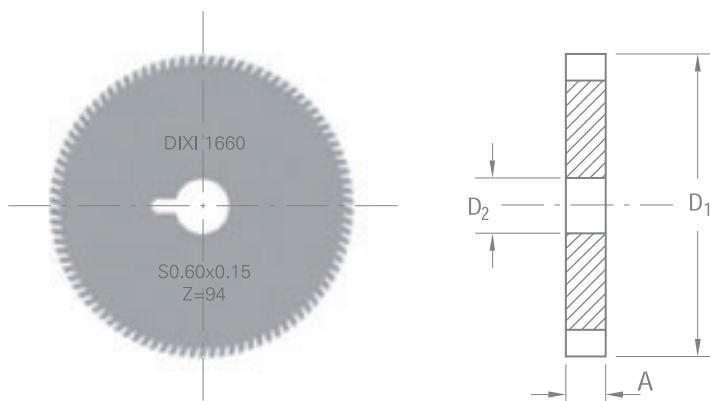

Acier + Pb	Acier faibl. allié	Acier fort. allié	Acier inox aust.	Titane, alliage de titane
Alliage Cu Argent Or	Alliage Cu difficile			

D nom.	Pas	D ₁ ±0.03	D ₂ h5	A	L ₁	D ₃	Réf.	CARBURE
S 0.40	0.10	45	8	3	1.00	35	B	301926
					1.00	35	C	301927
S 0.50	0.125	45	8	3	1.10	35	B	301928
					1.10	35	C	301929
S 0.60	0.15	45	8	3	1.35	35	B	301930
					1.35	35	C	301305
					3.00	-	A	301931
S 0.70	0.175	45	8	3	1.60	35	B	301932
					1.60	35	C	301943
					3.00	-	A	301945
S 0.80	0.20	45	8	3	1.80	35	B	301946
					1.80	35	C	301947
					3.00	-	A	301948
S 0.90	0.225	45	8	3	2.00	35	B	301949
					2.00	35	C	301950
					3.00	-	A	301951
S 1.00	0.25	45	8	3	3.00	-	A	301952
S 1.40	0.30	45	8	3	3.00	-	A	301953

Réf. A

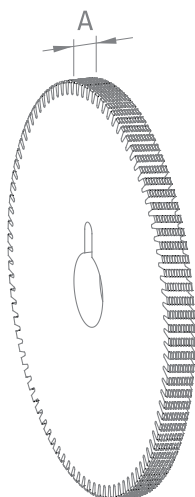

Réf. B

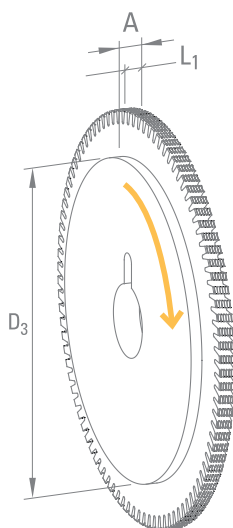

Réf. C

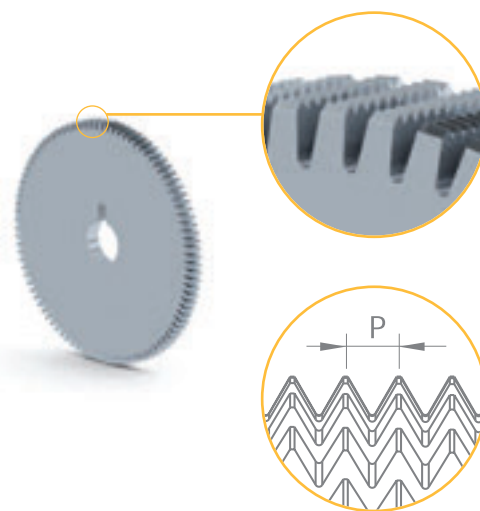
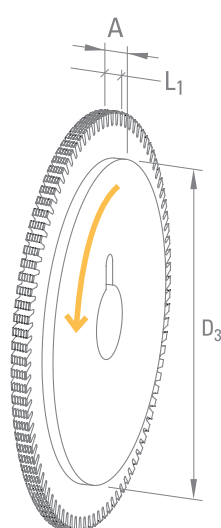

DIXI 7910

FRAISES À FILETER

Z = 2-4



P. 318



P. 326



ISO
60°

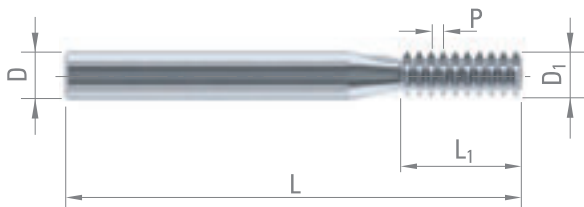

Acier + Pb	Acier faibl. allié	Acier fort. allié	Acier inox aust.	Fontes
Titane, alliage de titane	Alliage Cu Argent Or	Alliage Cu difficile	Alu	Plastique

D nom.	Pas	D ₁	L ₁	D _{h5}	L	Z	CARBURE	TAIN
M 1.4	0.30	0.90	2.10	3	38	2	41565	56990
M 1.6	0.35	1.00	2.45	3	38	2	41566	56991
M 2.0	0.40	1.30	3.20	3	38	2	41568	56993
M 2.3	0.40	1.50	3.20	3	38	2	41569	56994
M 2.5	0.35	1.30	2.80	3	38	2	41567	56992
M 2.5	0.45	1.50	3.60	3	38	2	41570	56995
M 3.0	0.50	2.10	4.50	3	38	3	41571	56996
M 4.0	0.50	2.60	5.50	3	38	3	41572	56997
M 4.0	0.70	2.60	6.30	3	38	3	41573	56998
M 4.5	0.75	3.00	6.75	4	42	3	41574	56999
M 5.0	0.80	3.60	8.00	4	42	3	41576	57001
M 6.0	1.00	4.00	9.00	6	57	3	42578	55510
M 8.0	0.75	5.90	15.00	6	57	3	42577	57000
M 8.0	1.25	5.00	12.50	6	57	3	42579	57003
M 10.0	1.50	5.90	15.00	6	57	3	42580	57004
M 12.0	1.00	7.90	20.00	8	63	4	42554	57002
M 12.0	1.75	7.90	19.25	8	63	4	42590	57007
M 14.0	1.50	9.90	24.00	10	72	4	42561	57005
M 14.0	2.00	9.90	24.00	10	72	4	42591	57008
M 18.0	1.50	11.90	30.00	12	83	4	42589	57006
M 18.0	2.00	11.90	30.00	12	83	4	42592	57009
M 18.0	2.50	11.90	30.00	12	83	4	42593	57010
M 24.0	3.00	15.90	36.00	16	92	4	42594	

DIXI 7910 E = Extérieur

D nom.	Pas	D ₁	L ₁	D _{h5}	L	Z	CARBURE	TAIN
M 3.0	0.50	5.90	15.00	6	57	3	42597	57013
M 4.5	0.75	7.90	19.50	8	63	4	42598	57014
M 6.0	1.00	9.90	24.00	10	72	4	41471	57015
M 10.0	1.50	11.90	30.00	12	83	4	41472	57016
M 14.0	2.00	11.90	30.00	12	83	4	41473	57017



DIXI 7908

FRAISES À FILETER HÉLICOÏDALES

Z = 3-6



P. 318



P. 328



ISO
60°

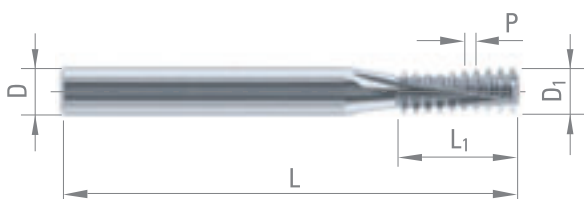

Acier + Pb	Acier faibl. allié	Acier fort. allié	Acier inox aust.	Fontes
Titane, alliage de titane	Alliage Cu Argent Or	Alliage Cu difficile	Alu	Plastique

D nom.	Pas	D ₁	L ₁	D _{h5}	L	Z	CARBURE	TiAIN
M 2.0	0.40	1.30	3.20	3	38	3	67417	952932
M 2.3	0.40	1.50	3.20	3	38	3	951593	952933
M 2.5	0.45	1.50	3.60	3	38	3	67419	952937
M 3.0	0.50	2.10	4.50	3	38	3	67420	952938
M 4.0	0.50	2.60	5.50	3	38	3	951594	952939
M 4.0	0.70	2.60	6.30	3	38	3	67452	952940
M 4.5	0.75	3.00	6.75	4	42	3	67453	952941
M 5.0	0.80	3.60	8.00	4	42	3	67454	952942
M 6.0	1.00	4.00	9.00	6	57	3	67455	952013
M 8.0	0.75	5.90	15.00	6	57	5	67461	952944
M 8.0	1.25	5.00	12.50	6	57	3	67274	952014
M 10.0	1.50	5.90	15.00	6	57	5	67456	952015
M 12.0	0.50	9.90	10.00	10	50	5	957036	957037
M 12.0	1.00	7.90	20.00	8	63	5	67462	952946
M 12.0	1.75	7.90	19.25	8	63	5	67457	952016
M 14.0	1.50	9.90	24.00	10	72	5	67463	952948
M 14.0	2.00	9.90	24.00	10	72	5	67459	952949
M 18.0	1.50	11.90	30.00	12	83	5	67464	952951
M 18.0	2.00	11.90	30.00	12	83	5	67465	952956
M 18.0	2.50	11.90	30.00	12	83	5	67458	952851
M 24.0	3.00	15.90	36.00	16	92	6	67460	952953

DIXI 7908 E = Extérieur

D nom.	Pas	D ₁	L ₁	D _{h5}	L	Z	CARBURE	TiAIN
M 3.0	0.50	5.90	15.00	6	57	5	67466	952943
M 4.5	0.75	7.90	19.50	8	63	5	67467	952945
M 6.0	1.00	9.90	24.00	10	72	5	67468	952947
M 10.0	1.50	11.90	30.00	12	83	5	67469	952950
M 14.0	2.00	11.90	30.00	12	83	5	67470	952952



DIXI 7913

FRAISES À FILETER ISO, PAS FIN À TROU DE LUBRIFICATION

Z = 4-5



P. 318



P. 328

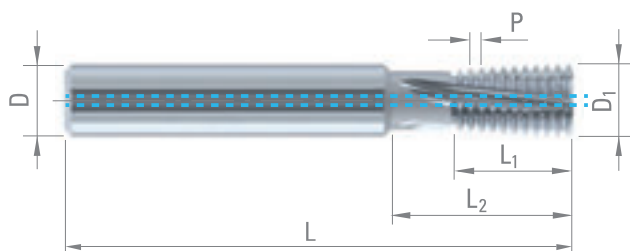

Acier + Pb	Acier faibl. allié	Acier fort. allié	Acier inox aust.	Fontes
Titane, alliage de titane	Alliage Cu Argent Or	Alliage Cu difficile	Alu	Plastique

Pas	D nom.	D ₁	L ₁	L ₂	D _{h5}	L	Z	CARBURE	CUTINOX
0.50	M 10	7.95	16	-	8	64	4	303435	303455
	M 14	11.95	20	31	12	80	4	303436	303456
0.75	M 10	7.95	16	-	8	64	4	303437	303457
	M 12	9.95	16	25	10	70	4	303438	303458
1.00	M 14	11.95	20	31	12	80	4	303439	303459
	M 12	9.95	16	25	10	70	4	303440	303460
	M 16	11.95	20	31	12	80	4	303441	303461
	M 20	15.95	25	40	16	90	5	303442	303462
1.25	M 24	19.95	33	50	20	105	5	303443	303463
	M 14	9.95	16	25	10	70	4	303444	303464
1.50	M 16	11.95	20	31	12	80	4	303445	303465
	M 14	9.95	16	25	10	70	4	303446	303466
	M 16	11.95	20	31	12	80	4	303447	303467
	M 22	15.95	25	40	16	90	5	303448	303468
2.00	M 26	19.95	33	50	20	105	5	303449	303469
	M 16	11.95	20	31	12	80	4	303450	303470
	M 22	15.95	25	40	16	90	5	303451	303471
2.50	M 27	19.95	33	50	20	105	5	303452	303472
	M 22	15.95	25	40	16	90	5	303453	303473
	M 30	19.95	33	50	20	105	5	303454	303474

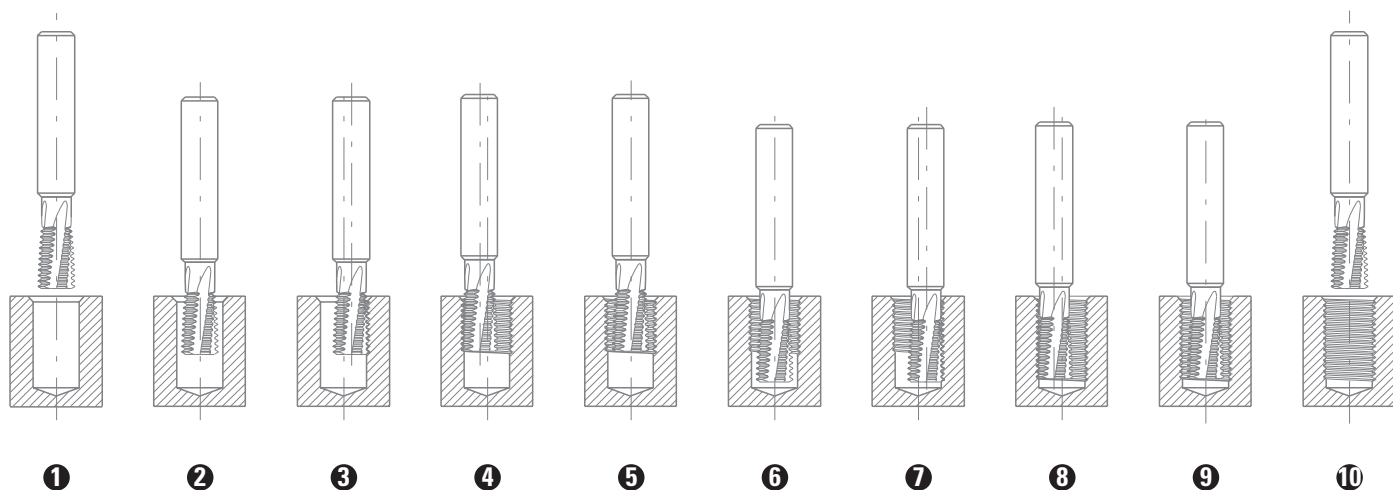

FRAISES À FILETER

Z = 2-4



P. 318



P. 326

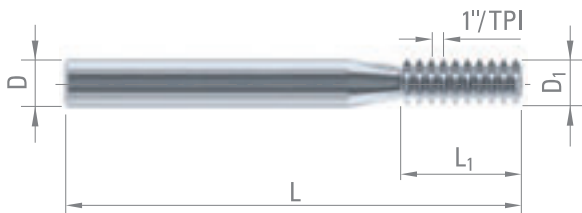

Acier + Pb	Acier faibl. allié	Acier fort. allié	Acier inox aust.	Fontes
Titane, alliage de titane	Alliage Cu Argent Or	Alliage Cu difficile	Alu	Plastique

UNC	UNF	UNEF	UN	TPI	D ₁	L ₁	D _{h5}	L	Z	CARBURE	TiAIN
N°2	N°3			56	1.50	3.17	3	38	2	41581	953797
N°3	N°4			48	1.50	3.17	3	38	2	39808	953796
N°5	N°6			40	2.10	4.44	3	38	3	41582	953798
	N°8			36	3.00	6.35	4	42	3	39811	953799
N°8	N°10	N°12		32	3.00	6.35	4	42	3	41583	65997
		5/16"	7/16"	32	5.90	14.28	6	57	3	39813	953806
		N°12	5/16"	28	3.60	8.16	4	42	3	41584	64133
		7/16"	9/16"	28	7.90	19.95	8	63	4	39815	953812
N°12	5/16"			24	4.00	8.46	6	57	3	41585	953802
1/4"			5/16"	20	4.00	10.16	6	57	3	42599	953800
	1/2"	3/4"	9/16"	20	9.90	22.86	10	72	4	41475	953819
5/16"				18	5.00	12.70	6	57	3	41587	953803
	9/16"			18	9.90	23.98	10	72	4	41476	953817
3/8"			7/16"	16	5.90	14.28	6	57	3	42600	953804
			5/8"	16	11.90	28.57	12	83	4	42601	63605
7/16"				14	7.90	16.33	8	63	4	41478	953808
1/2"				13	7.90	19.53	8	63	4	39824	953807
9/16"			5/8"	12	9.90	23.28	10	72	4	39825	953815
	1"		1-1/16"	12	11.90	29.63	12	83	4	39826	63606
5/8"				11	9.90	23.09	10	72	4	39827	953814
3/4"				10	11.90	27.94	12	83	4	39828	953820

DIXI 7920 E = Extérieur

D nom.	TPI	D ₁	L ₁	D _{h5}	L	Z	CARBURE	TiAIN
UNC N°6	32	5.90	14.28	6	57	3	39850	953805
UNF N°12	28	7.90	19.95	8	63	4	39851	953810
UNC 1/4"	20	9.90	22.86	10	72	4	39852	953818
UNC 5/16"	18	9.90	23.98	10	72	4	39853	953816
UNC 3/8"	16	11.90	28.57	12	83	4	39854	953822
UNC 9/16"	12	11.90	29.63	12	83	4	39855	953821



DIXI 7918

FRAISES À FILETER HÉLICOÏDALES

Z = 3-5



P. 318



P. 328



Acier + Pb	Acier faibl. allié	Acier fort. allié	Acier inox aust.	Fontes
Titane, alliage de titane	Alliage Cu Argent Or	Alliage Cu difficile	Alu	Plastique

UNC	UNF	UNEF	UN	TPI	D ₁	L ₁	D _{h5}	L	Z	CARBURE	TiAIN
	N°2			64	1.50	3.17	3	38	3	951595	952964
N°2	N°3			56	1.50	3.17	3	38	3	67489	952963
N°3	N°4			48	1.50	3.17	3	38	3	67490	952962
	N°5			44	2.10	4.62	3	38	3	951482	952966
N°5	N°6			40	2.10	4.44	3	38	3	67491	952965
	N°8			36	3.00	6.35	4	42	3	67492	952968
N°8	N°10	N°12		32	3.00	6.35	4	42	3	67493	952967
		5/16"	7/16"	32	5.90	14.28	6	57	5	67497	952975
	N°12		5/16"	28	3.60	8.16	4	42	3	67494	952969
		7/16"	9/16"	28	7.90	19.95	8	63	5	67498	952979
N°12	5/16"	5/8"		24	4.00	8.46	6	57	3	67495	952971
1/4"			5/16"	20	4.00	10.16	6	57	3	67496	952970
	1/2"	3/4"	9/16"	20	9.90	22.86	10	72	5	67499	952985
5/16"				18	5.00	12.70	6	57	3	67500	952972
	9/16"			18	9.90	23.98	10	72	5	67501	952983
3/8"			7/16"	16	5.90	14.28	6	57	5	67502	952973
			5/8"	16	11.90	28.57	12	83	5	67503	952990
7/16"				14	7.90	16.33	8	63	5	67504	952977
1/2"				13	7.90	19.53	8	63	5	67505	952976
9/16"				12	9.90	23.28	10	72	5	67512	952981
	1"		1-1/16"	12	11.90	29.63	12	83	5	67506	952988
5/8"				11	9.90	23.09	10	72	5	951597	952980
3/4"				10	11.90	27.94	12	83	5	951667	952986

DIXI 7918 E = Extérieur

D nom.	TPI	D ₁	L ₁	D _{h5}	L	Z	CARBURE	TiAIN
UNC N°6	32	5.90	14.28	6	57	5	67507	952974
UNF N°12	28	7.90	19.95	8	63	5	67508	952978
UNC 1/4"	20	9.90	22.86	10	72	5	67509	952984
UNC 5/16"	18	9.90	23.98	10	72	5	67510	952982
UNC 3/8"	16	11.90	28.57	12	83	5	67511	952989
UNC 9/16"	12	11.90	29.63	12	83	5	951668	952987



DIXI 7923

FRAISES À FILETER HÉLICOÏDALES À TROU DE LUBRIFICATION

$$L_1 = 2 \times \emptyset \text{ nom.}$$

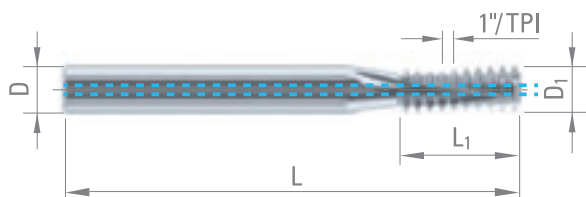

Z = 3-4



P. 319



P. 328



Acier + Pb	Acier faibl. allié	Acier fort. allié	Acier inox aust.	Fontes
Titane, alliage de titane	Alliage Cu Argent Or	Alliage Cu difficile	Alu	Plastique

UNJF	TPI	D ₁	L ₁	D _{h5}	L	Z	CARBURE
N°10	32	3.90	11.50	6	54	3	303381
1/4"	28	5.20	14.00	6	54	3	303382
5/16"	24	5.95	17.40	6	54	3	303383
3/8"	24	7.95	20.60	8	64	4	303384
7/16"	20	7.95	24.70	8	64	4	303385
1/2"	20	9.95	27.30	10	74	4	303386

DIXI 7940

FRAISES À FILETER

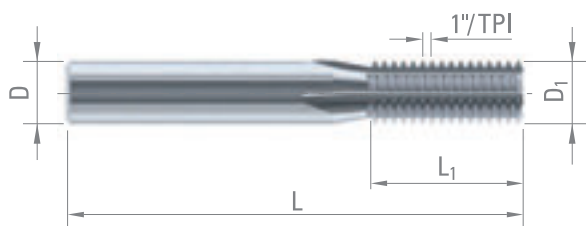

Z = 3-4



P. 319



P. 326



Acier + Pb	Acier faibl. allié	Acier fort. allié	Acier inox aust.	Fontes
Titane, alliage de titane	Alliage Cu Argent Or	Alliage Cu difficile	Alu	Plastique

BSP	TPI	D ₁	L ₁	D _{h5}	L	Z	CARBURE
G1/16" – G1/8"	28	5.90	14.51	6	57	3	42603
G1/4" – G3/8"	19	7.90	18.71	8	63	4	42604
G1/2" – G5/8" – G3/4" – G7/8"	14	11.90	29.02	12	83	4	42605
G1"	11	15.90	34.63	16	92	4	42606

Pour filetages intérieurs et extérieurs



DIXI 7946

FRAISES À FILETER

Z = 3-4



P. 326

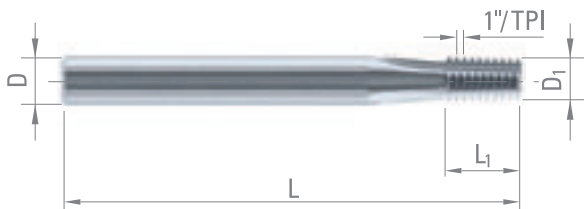

Acier + Pb	Acier faibl. allié	Acier fort. allié	Acier inox aust.	Fontes
Titane, alliage de titane	Alliage Cu Argent Or	Alliage Cu difficile	Alu	Plastique

BSPT	TPI	D ₁	L ₁	D _{h5}	L	Z	CARBURE
R1/16" – R1/8"	28	5.34	9.97	6	57	3	42607
R1/4" – R3/8"	19	7.07	14.70	8	63	4	42608
R1/2" – R5/8" – R3/4" – R7/8"	14	10.77	19.95	12	83	4	41590
R1" => R2-1/2"	11	14.32	27.70	16	92	4	42610

Pour filetages intérieurs et extérieurs

DIXI 7950

FRAISES À FILETER

Z = 3-4



P. 326



Acier + Pb	Acier faibl. allié	Acier fort. allié	Acier inox aust.	Fontes
Titane, alliage de titane	Alliage Cu Argent Or	Alliage Cu difficile	Alu	Plastique

NPT	TPI	D ₁	L ₁	D _{h5}	L	Z	CARBURE
1/16" – 1/8"	27	5.37	9.40	6	57	3	39789
1/4" – 3/8"	18	7.10	14.11	8	63	4	41592
1/2" – 3/4"	14	10.65	19.95	12	83	4	42611
1" – 1-1/4" – 1-1/2" – 2"	11.5	14.38	26.50	16	92	4	39792

Pour filetages intérieurs et extérieurs



DIXI 7956

FRAISES À FILETER

Z = 3-4



P. 326



Acier + Pb	Acier faibl. allié	Acier fort. allié	Acier inox aust.	Fontes
Titane, alliage de titane	Alliage Cu Argent Or	Alliage Cu difficile	Alu	Plastique

NPTF	TPI	D ₁	L ₁	D _{h5}	L	Z	CARBURE
1/16" – 1/8"	27	5.37	9.40	6	57	3	39794
1/4" – 3/8"	18	7.10	14.11	8	63	4	39795
1/2" – 3/4"	14	10.65	19.95	12	83	4	39796
1" – 1-1/4" – 1-1/2" – 2"	11.5	14.38	26.50	16	92	4	41591

Pour filetages intérieurs et extérieurs

DIXI 7915

FRAISES À FILETER ET CHANFREINER À TROU DE LUBRIFICATION

Z = 3-4

L₁ = 2 x Ø nom.

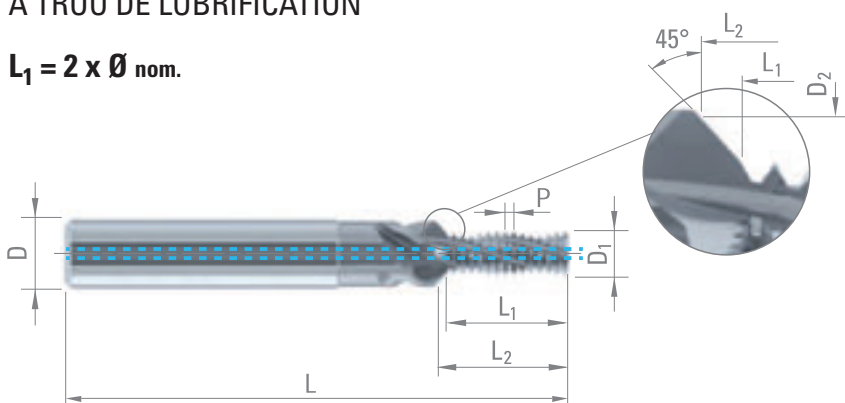

P. 318



P. 328



Acier + Pb	Acier faibl. allié	Acier fort. allié	Acier inox aust.	Fontes
Titane, alliage de titane	Alliage Cu Argent Or	Alliage Cu difficile	Alu	Plastique

D nom.	Pas	D ₁	D ₂	L ₁	L ₂	D _{h5}	L	Z	CARBURE	CUTINOX
M 4.0	0.70	3.10	4.2	8.70	9.3	6	48	3	303387	303394
M 5.0	0.80	3.90	5.3	10.70	11.5	6	54	3	303388	303395
M 6.0	1.00	4.70	6.3	13.40	14.3	8	62	3	303389	303396
M 8.0	1.25	6.40	8.4	18.10	19.1	10	74	3	303390	303397
M 10.0	1.50	8.10	10.5	21.70	22.9	12	80	4	303391	303398
M 12.0	1.75	9.95	12.6	25.30	26.7	14	90	4	303392	303399
M 16.0	2.00	13.40	16.8	34.90	36.6	18	102	4	303393	303400



DIXI 7925

FRAISES À FILETER ET CHANFREINER À TROU DE LUBRIFICATION

$L_1 = 2 \times \varnothing_{nom.}$

Z = 3-4

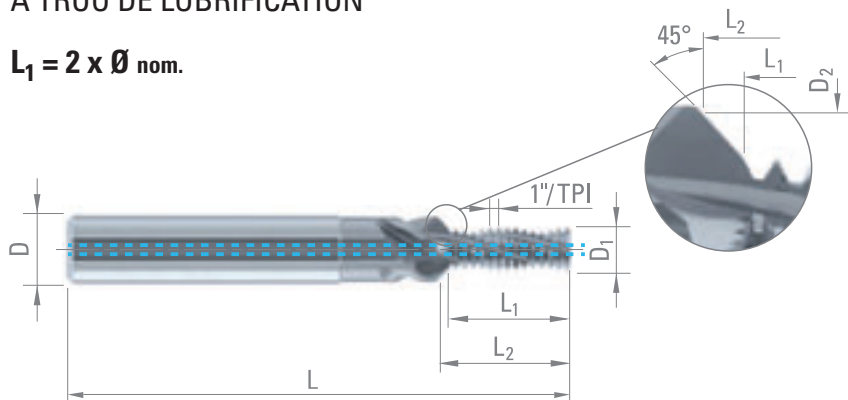

P. 318



P. 328



Acier + Pb	Acier faibl. allié	Acier fort. allié	Acier inox aust.	Fontes
Titane, alliage de titane	Alliage Cu Argent Or	Alliage Cu difficile	Alu	Plastique

UNC	TPI	D ₁	D ₂	L ₁	L ₂	D _{h5}	L	Z	CARBURE CUTINOX
N°8	32	3.10	4.4	9.10	9.7	6	48	3	303401 303411
N°10	24	3.60	5.1	11.00	11.9	6	54	3	303402 303412
N°12	24	4.10	5.8	12.10	13.0	6	54	3	303403 303413
1/4"	20	4.80	6.7	14.50	15.6	8	62	3	303404 303414
5/16"	18	5.95	8.3	17.60	18.7	10	74	3	303405 303415
3/8"	16	7.50	10.0	21.40	22.6	12	80	4	303406 303416
7/16"	14	8.80	11.7	24.40	25.9	12	80	4	303407 303417
1/2"	13	10.30	13.3	28.20	29.8	14	90	4	303408 303418
9/16"	12	10.80	15.0	30.60	32.3	16	102	4	303409 303419
5/8"	11	11.90	16.7	35.70	37.6	18	102	4	303410 303420

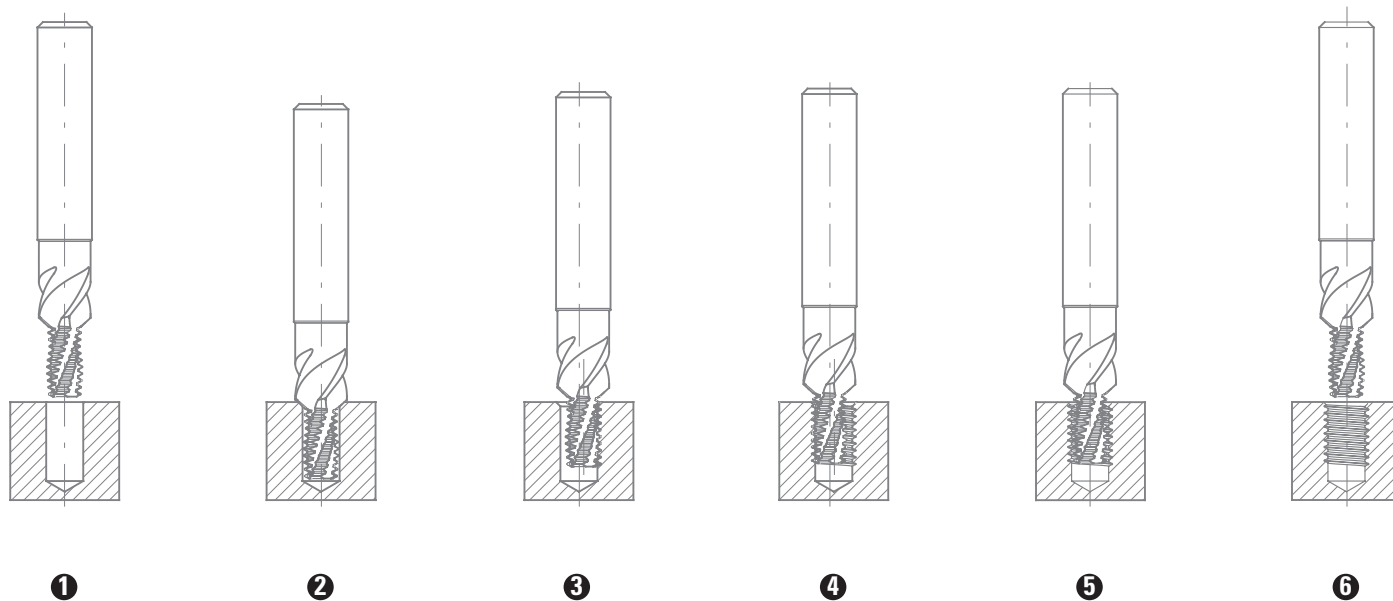

DIXI 7985

FRAISES À PERCER, FILETER ET CHANFREINER À TROUS DE LUBRIFICATION

Z = 2

$L_1 = 2 \times \emptyset \text{ nom.}$

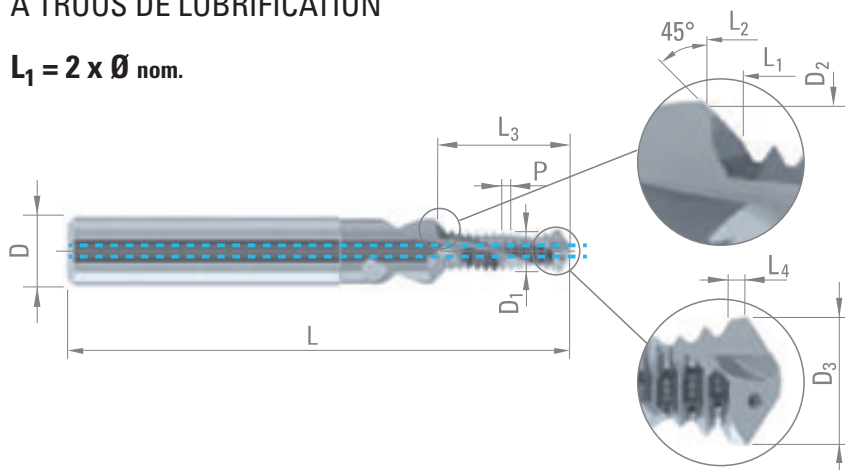

P. 318



P. 330



Fontes

Alliage Cu
Argent
Or

Alliage
Cu
difficile

Alu

D nom.	Pas	D ₁	D ₂	D ₃	L ₁	L ₂	L ₃	L ₄	D _{h5}	L	CARBURE CUTINOX
M 4.0	0.70	3.20	4.2	3.30	8.90	8.9	9.5	0.7	6	48	303421 303428
M 5.0	0.80	4.00	5.3	4.20	11.10	11.0	11.8	0.8	6	54	303422 303429
M 6.0	1.00	4.75	6.3	5.00	13.85	13.7	14.6	1.0	8	62	303423 303430
M 8.0	1.25	6.35	8.4	6.75	18.60	18.4	19.6	1.3	10	74	303424 303431
M 10.0	1.50	7.95	10.5	8.50	22.40	22.2	23.7	1.5	12	80	303425 303432
M 12.0	1.75	9.95	12.6	10.25	26.00	25.5	27.4	1.5	14	90	303426 303433
M 16.0	2.00	13.20	16.8	14.00	35.90	35.1	37.6	1.5	18	102	303427 303434

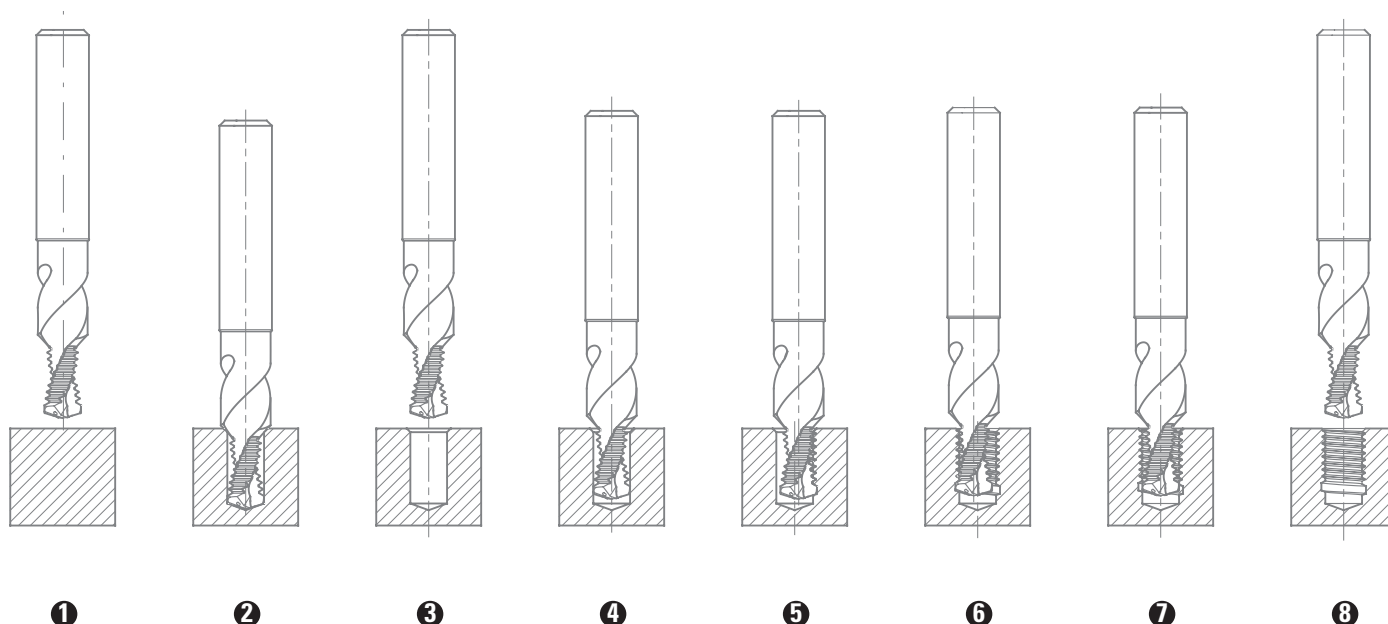



POSITIONNEMENT DES TOLÉRANCES DE DIAMÈTRES SUR FLANCS POUR LES FILETAGES MINIATURES S (ISO 1501 / NIHS 06-05 / DIN 14)

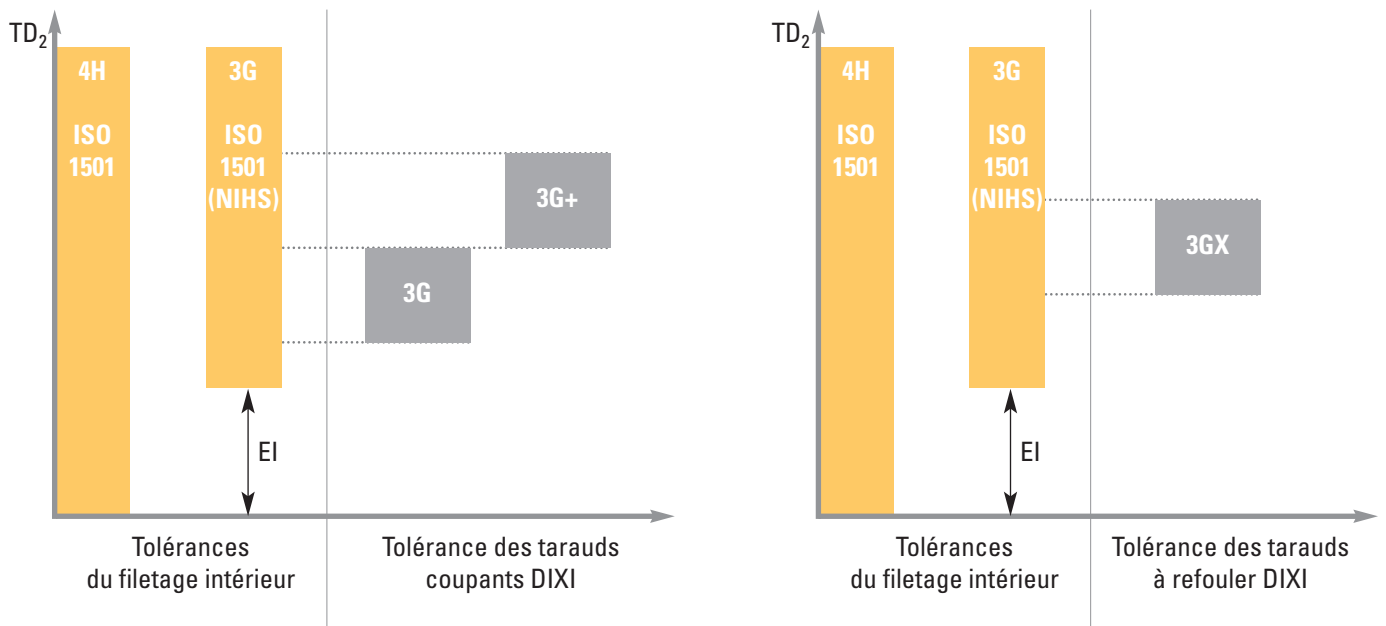

POSITIONNEMENT DES TOLÉRANCES DE DIAMÈTRES SUR FLANCS POUR LES FILETAGES INTÉRIEURS MÉTRIQUES M (ISO 965 / NIHS 06-06 / DIN 13)

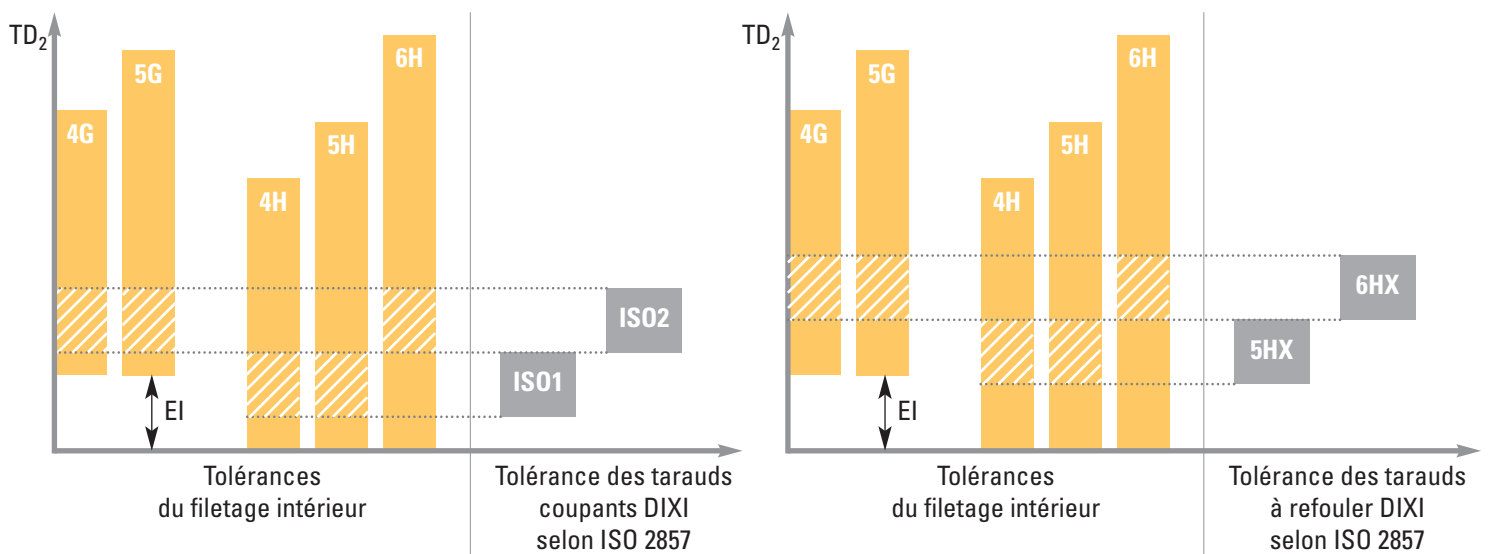



LEXIQUE TECHNIQUE JAUGES NIHS

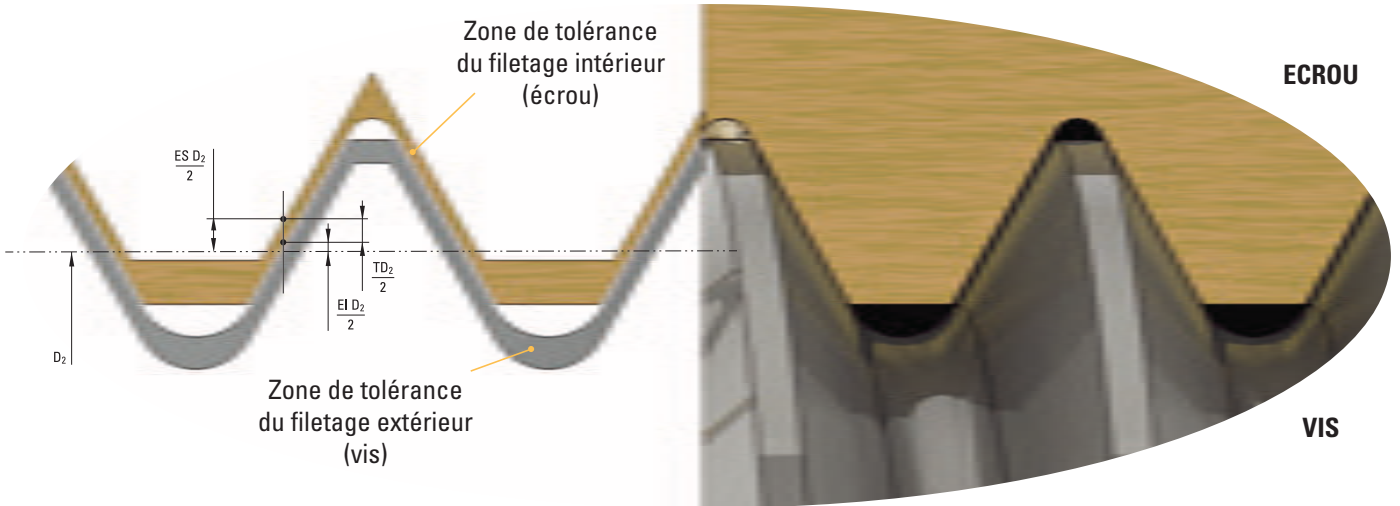

D_2	Diamètre sur flancs.
Ecart $EI D_2$	Ecart inférieur du diamètre sur flancs D_2 .
Ecart $ES D_2$	Ecart supérieur du diamètre sur flancs D_2 .
Tolérance TD_2	Tolérance du diamètre sur flancs D_2 . Elle est égale à $ES D_2 - EI D_2$.
Critère de tolérance NIHS NT	NT est l'abréviation de "Normal Tolerance". Ce critère est utilisé pour le contrôle des taraudages S de pièces terminées (avec ou sans revêtement galvanique).
Critère de tolérance NIHS RT	RT est l'abréviation de "Reduced Tolerance" ou tolérance réduite. Ce critère est utilisé pour le contrôle des taraudages S de pièces brutes en production (avant revêtement galvanique).
Jauges NO GO	Les jauges NO GO sont identiques, que ce soit en critère de tolérance NT ou RT. Elles sont utilisées pour le contrôle de pièces brutes (au stade de la production) ou de pièces finies (avec ou sans revêtement galvanique).

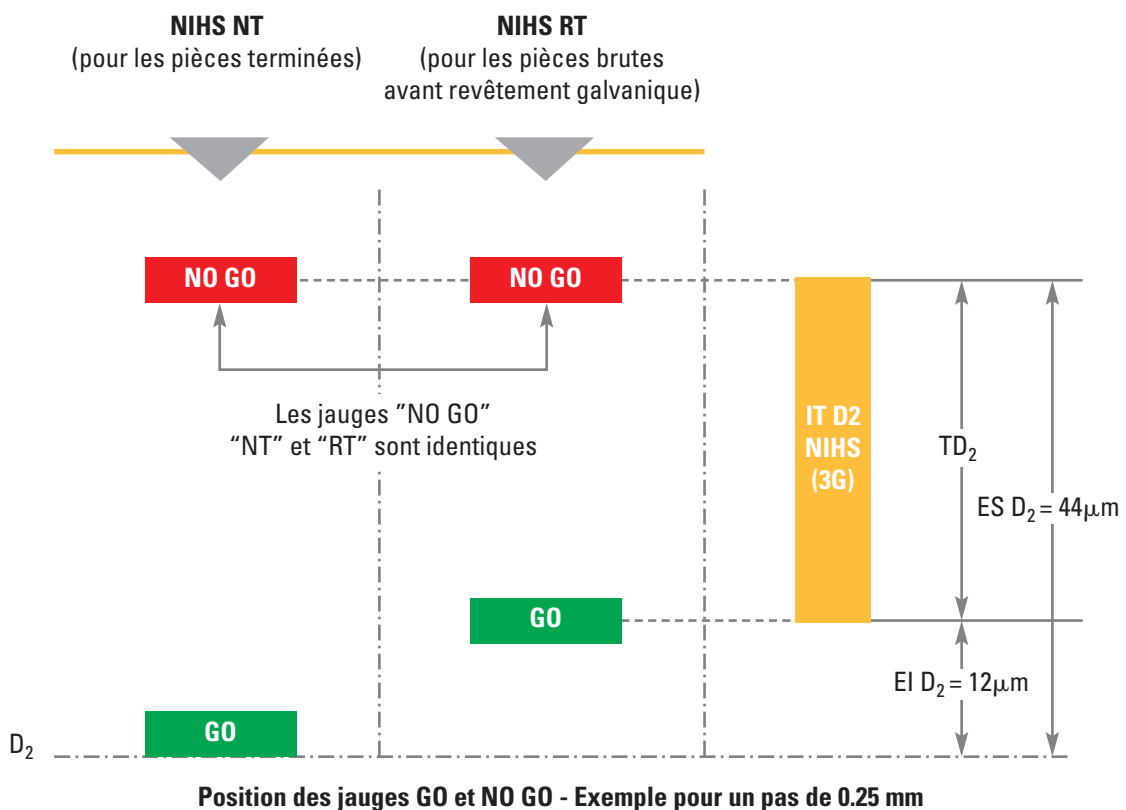

FILETAGE AF - AVANTAGES TECHNIQUES

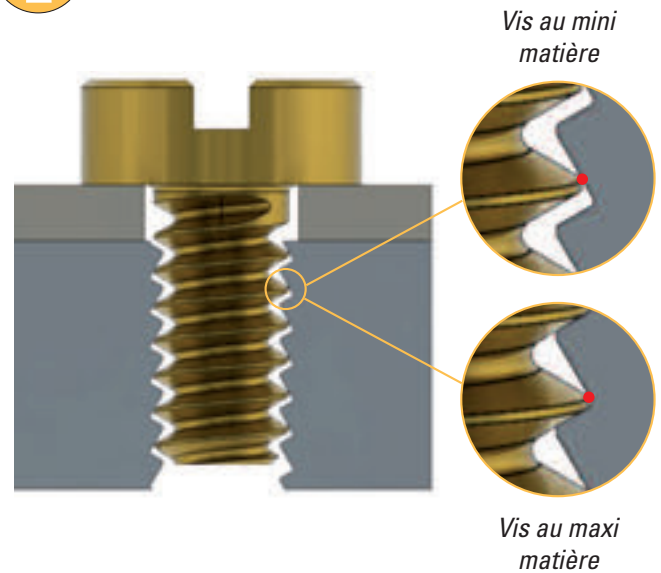
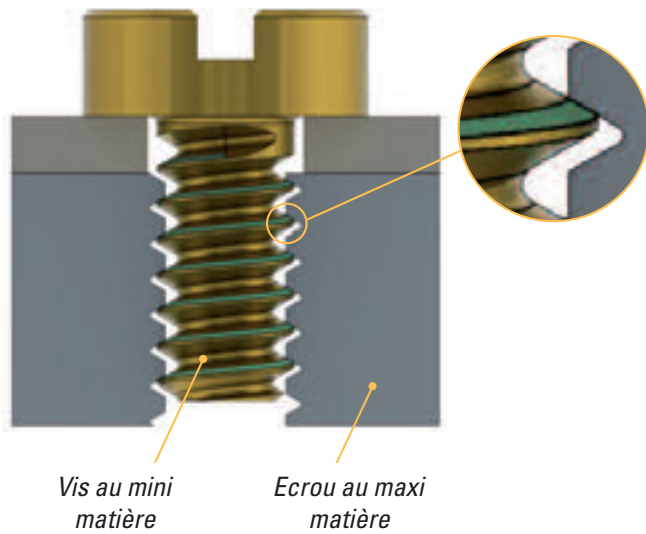

Au jeu des tolérances, sur un assemblage S 1.00x0.25, il peut y avoir jusqu'à 0.05 mm au rayon d'espace libre entre le \varnothing extérieur de la vis et le \varnothing extérieur de l'écrrou. Tout cet espace laisse un degré de liberté à la vis qui, sous l'effet de vibrations, peut se desserrer. Le phénomène est d'autant plus accentué que la surface de contact théorique entre la vis et l'écrrou est faible. Pour éviter les phénomènes de vibrations et ainsi le desserrage, il est possible d'utiliser du frein-filet. Mais cette solution n'est pas appropriée pour les assemblages dont l'aspect visuel a une grande importance (horlogerie, ...).

Avec un filetage autofrein AF, que la vis soit au maxi ou au mini matière, le contact entre la vis et l'écrrou ne varie pas. Les tolérances de fabrication n'ont donc aucune influence sur la qualité de l'assemblage.

**Avec un filetage autofrein AF,
nul besoin d'utiliser de frein filet.**

SENS DE PROFIL - SENS DE TRAVAIL

Le profil du filetage AF n'est pas symétrique comme peut l'être un filetage ISO à 60°. Selon le sens de travail de l'outil, le profil coupant est inversé.

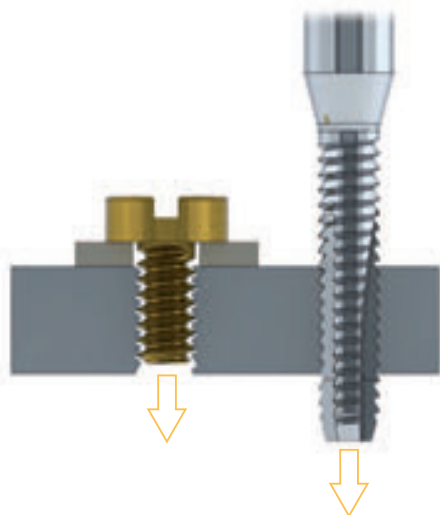

AF/BT

L'outil et la vis entrent dans le même sens de vissage.
OUTILS STOCKÉS

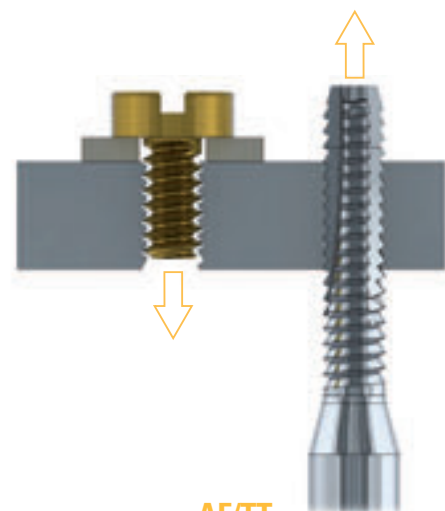

AF/TT

L'outil et la vis entrent dans une direction de vissage inversée.
OUTILS SUR DEMANDE



Ø DE PERÇAGE AVANT TARAUDAGE OU FILETAGE



UNEF (ANSI B1.1 / ISO 5854)

Ø nominal	Pas	Tolérance	Ø noyau		Ø perçage
			min.	max.	
N°12	32	2B	4.623	4.826	4.70
1/4"	32	2B	5.487	5.689	5.60
5/16"	32	2B	7.087	7.264	7.20
3/8"	32	2B	8.662	8.864	8.75
7/16"	28	2B	10.135	10.337	10.25
1/2"	28	2B	11.710	11.938	11.85
9/16"	24	2B	13.132	13.385	13.20
5/8"	24	2B	14.732	14.986	14.80
11/16"	24	2B	16.307	16.560	16.40
3/4"	20	2B	17.679	17.957	17.80

UNJF (ISO 3161)

Ø nominal	Pas	Tolérance	Ø noyau		Ø perçage
			min.	max.	
N°10	32	3B	4.054	4.255	4.10
1/4"	28	3B	5.466	5.662	5.55
5/16"	24	3B	6.906	7.109	7.00
3/8"	24	3B	8.494	8.679	8.60
7/16"	20	3B	9.876	10.084	10.00
1/2"	20	3B	11.463	11.661	11.55

BSP (ISO 228)

Ø nominal	Pas	Ø noyau		Ø perçage
		min.	max.	
G 1/16"	28	6.561	6.843	6.75
G 1/8"	28	8.566	8.848	8.75
G 1/4"	19	11.445	11.890	11.60
G 3/8"	19	14.950	15.395	15.20
G 1/2"	14	18.631	19.172	18.90
G 5/8"	14	20.587	21.128	20.90
G 3/4"	14	24.117	24.658	24.40
G 7/8"	14	27.877	28.418	28.20
hG 1"	11	30.291	30.931	30.70

COMBINAISONS DE DIAMÈTRES NOMINAUX ET PAS SELON NORME ANSI B1.1 / ISO 5854

Ø nom.		80	72	64	56	48	44	40	36	32	28	24	20	18	16	14	13	12	11	10	TPI	
inch	mm	0.318	0.353	0.397	0.454	0.529	0.577	0.635	0.706	0.794	0.907	1.058	1.270	1.411	1.588	1.814	1.954	2.117	2.309	2.54	mm	
N°0	1.524	UNF																				
N°1	1.854		UNF	UNC																		
N°2	2.184			UNF	UNC																	
N°3	2.515				UNF	UNC																
N°4	2.845					UNF		UNC														
N°5	3.175						UNF	UNC														
N°6	3.505							UNF		UNC												
N°8	4.166								UNF	UNC												
N°10	4.826									UNF		UNC										
N°12	5.486									UNEF	UNF	UNC										
1/4"	6.350									UNEF	UNF		UNC									
5/16"	7.938									UNEF	UN	UNF	UN	UNC								
3/8"	9.525									UNEF	UN	UNF	UN		UNC							
7/16"	11.113									UN	UNEF	UNF			UN	UNC						
1/2"	12.700									UN	UNEF		UNF		UN		UNC					
9/16"	14.288									UN	UN	UNEF	UN	UNF	UN				UNC			
5/8"	15.875									UN	UN	UNEF	UN	UNF	UN				UN	UNC		
11/16"	17.463									UN	UN	UNEF	UN		UN				UN			
3/4"	19.050									UN	UN		UNEF		UNF				UN		UNC	
13/16"	20.638									UN	UN		UNEF		UN				UN			
7/8"	22.225									UN	UN		UNEF		UN	UNF			UN			
15/16"	23.813									UN	UN		UNEF		UN				UN			
1"	25.400									UN	UN		UNEF		UN				UNF			
1-1/16"	26.988										UN		UN	UN	UN				UN			

CONDITIONS DE COUPE

USINAGE AVEC PIÈCE FIXE

Matières à usiner			CARBURE		TiAlN		CUTINOX	
			Vc [m/min]		Vc [m/min]		Vc [m/min]	
P	Acier non allié / faiblement allié	< 600 N/mm ²	65	80	70	100		
P	Acier non allié / faiblement allié	600 – 1500 N/mm ²			40	60		
P	Acier fortement allié	700 – 1500 N/mm ²			25	50	60	80
M	Acier inoxydable	400 – 700 N/mm ²	35	40	40	60	70	90
M	Acier inox. DUPLEX, acier austénitique inox. sans nickel	> 800 N/mm ²			25	50	60	80
K	Fonte grise / Fonte à graphite sphéroïdal perlitique	< 250 HB	65	80	70	100		
K	Fonte allié / Fonte à graphite sphéroïdal perlitique	> 250 HB	35	40	40	60		
K	Fonte à graphite sphéroïdal ferritique / Fonte malléable		35	40	40	60		
S	Super alliages / Acier inox. réfractaire	Inconel Nimonic Hastelloy			25	50	40	60
S	Titane, alliage de titane		15	35				
N	Alliage de cuivre / bonne usinabilité (laiton – bronze)		80	200				
N	Alliage de cuivre / usinabilité difficile / Bronze à l'aluminium	(CuAlFe) (Ampco)	70	150				
N	Or, argent		80	200				

USINAGE AVEC DÉCOLLETEUSE - la pièce tourne

Matières à usiner		CARBURE	fz [mm]	fz [mm]	fz [mm]	fz [mm]
		Vc [m/min]	pas 0.20 - 0.25	pas 0.30 - 0.35	pas 0.40 - 0.50	pas 0.70 - 1.00
P	Aciers	50 - 100	0.002 - 0.004	0.002 - 0.004	0.003 - 0.006	0.005 - 0.013
M	Acier inoxydable	40 - 80	0.002 - 0.003	0.002 - 0.004	0.002 - 0.005	0.004 - 0.01
S	Titane, alliage de titane	50 - 90	0.002 - 0.003	0.002 - 0.004	0.002 - 0.005	0.004 - 0.01
N	Alliage de cuivre	60 - 150	0.002 - 0.005	0.002 - 0.006	0.003 - 0.007	0.005 - 0.013



$$n \text{ [tr/min]} = \frac{Vc \text{ [m/min]} \times 1000}{\pi \times D_1 \text{ [mm]}}$$

$$Vf \text{ [mm/min]} = n \text{ [tr/min]} \times fz \text{ [mm]} \times z$$

Avance par dent

fz [mm]

$\varnothing D_1$ 0.20 - 0.60	$\varnothing D_1$ 0.60 - 1.20	$\varnothing D_1$ 1.20 - 2.00	$\varnothing D_1$ 2.00 - 3.00	$\varnothing D_1$ 3.00 - 5.00	$\varnothing D_1$ 5.00 - 8.00
0.003 - 0.006	0.004 - 0.01	0.01 - 0.03	0.02 - 0.04	0.03 - 0.05	0.04 - 0.07
0.003 - 0.006	0.004 - 0.01	0.01 - 0.03	0.02 - 0.04	0.03 - 0.05	0.04 - 0.07
0.003 - 0.006	0.004 - 0.01	0.01 - 0.03	0.02 - 0.04	0.03 - 0.05	0.04 - 0.07
0.003 - 0.006	0.004 - 0.01	0.01 - 0.03	0.02 - 0.04	0.03 - 0.05	0.04 - 0.07
0.003 - 0.006	0.004 - 0.01	0.01 - 0.03	0.02 - 0.04	0.03 - 0.05	0.04 - 0.07
0.003 - 0.006	0.004 - 0.01	0.01 - 0.03	0.02 - 0.04	0.03 - 0.05	0.04 - 0.07
0.003 - 0.006	0.004 - 0.01	0.01 - 0.03	0.02 - 0.04	0.03 - 0.05	0.04 - 0.07
0.003 - 0.006	0.004 - 0.01	0.01 - 0.03	0.02 - 0.04	0.03 - 0.05	0.04 - 0.07
0.003 - 0.006	0.004 - 0.01	0.01 - 0.03	0.02 - 0.04	0.03 - 0.05	0.04 - 0.07
0.003 - 0.006	0.004 - 0.01	0.01 - 0.03	0.02 - 0.04	0.03 - 0.05	0.04 - 0.07
0.003 - 0.006	0.004 - 0.01	0.01 - 0.03	0.02 - 0.04	0.03 - 0.05	0.04 - 0.07
0.003 - 0.006	0.004 - 0.01	0.01 - 0.03	0.02 - 0.04	0.03 - 0.05	0.04 - 0.07
0.003 - 0.006	0.004 - 0.01	0.01 - 0.03	0.02 - 0.04	0.03 - 0.05	0.04 - 0.07
0.003 - 0.006	0.004 - 0.01	0.01 - 0.03	0.02 - 0.04	0.03 - 0.05	0.04 - 0.07
0.003 - 0.006	0.004 - 0.01	0.01 - 0.03	0.02 - 0.04	0.03 - 0.05	0.04 - 0.07
0.003 - 0.006	0.004 - 0.01	0.01 - 0.03	0.02 - 0.04	0.03 - 0.05	0.04 - 0.07
0.003 - 0.006	0.004 - 0.01	0.01 - 0.03	0.02 - 0.04	0.03 - 0.05	0.04 - 0.07
0.003 - 0.006	0.004 - 0.01	0.01 - 0.03	0.02 - 0.04	0.03 - 0.05	0.04 - 0.07

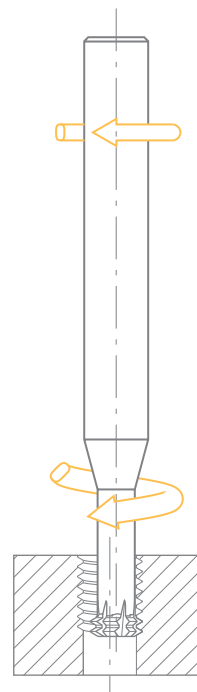

Exemple pour M2 x 0.40 dans le titane, DIXI 1730 $\varnothing D_1 = 1.55$

① Rotation outil $n \text{ (min}^{-1}\text{)} = \frac{1000 \times Vc}{\pi \times \varnothing D_1}$

$$\frac{1000 \times 90}{(\pi \times 1.55)} \Rightarrow 19'000 \text{ min}^{-1}$$

② Avance $Vf \text{ mm/min} = n \times fz \times z$

$$19'000 \times 0.004 \times 3 = 223 \text{ mm/min}$$

③ Rotation pièce $\text{min}^{-1} = \frac{Vf}{\varnothing \text{ fileté} \times \pi}$

$$\frac{223}{M2 \times \pi} \Rightarrow 36 \text{ min}^{-1}$$

Si nécessaire, convertir en degrés $nb^\circ = \text{min}^{-1} \times 360^\circ \Rightarrow 36 \text{ min}^{-1} \times 360^\circ = 12960^\circ$

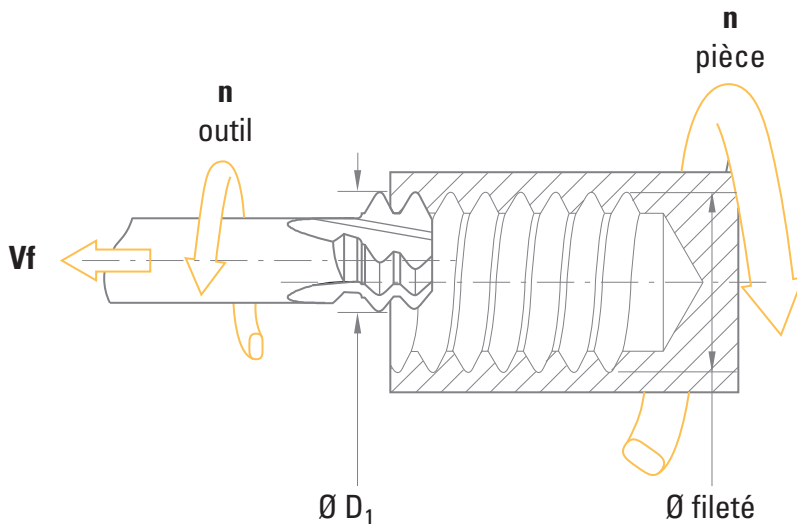

CONDITIONS DE COUPE

Matières à usiner			CARBURE		CUTINOX	
			Vc [m/min]		Vc [m/min]	
P	Acier non allié / faiblement allié	< 600 N/mm ²	100	150	120	180
P	Acier non allié / faiblement allié	600 – 1500 N/mm ²	90	130	110	150
P	Acier de décolletage au plomb		100	180	120	200
P	Acier fortement allié	700 – 1500 N/mm ²	40	70	50	80
M	Acier inoxydable	400 – 700 N/mm ²	50	80	60	110
M	Acier inox. DUPLEX, acier austénitique inox. sans nickel	> 800 N/mm ²	35	60	45	75
K	Fonte grise / Fonte à graphite sphéroïdal perlitique	< 250 HB	100	200	150	250
K	Fonte alliée / Fonte à graphite sphéroïdal perlitique	> 250 HB	100	140	120	160
K	Fonte à graphite sphéroïdal ferritique / Fonte malléable		70	110	80	140
S	Super alliages / Acier inox. réfractaire	Inconel Nimonic Hastelloy	20	45	30	60
S	Titane, alliage de titane		40	65	40	65
N	Alliage de cuivre / bonne usinabilité (laiton – bronze)		100	200	100	200
N	Alliage de cuivre / usinabilité difficile / Bronze à l'aluminium	(CuAlFe) (Ampco)	80	150	80	150
N	Alliage d'aluminium	Si < 8%	100	250	100	250
N	Fonte d'aluminium	Si > 8%	100	200	100	200
N	Graphite		100	200	100	200
N	Plastique		100	250	100	250
N	Or, argent		100	200	100	200



$$n \text{ [tr/min]} = \frac{Vc \text{ [m/min]} \times 1000}{\pi \times D_1 \text{ [mm]}}$$

$$Vf \text{ [mm/min]} = n \text{ [tr/min]} \times fz \text{ [mm]} \times z$$

Avance par dent **fz [mm]**

$\emptyset D_1$ 0.60 - 1.00	$\emptyset D_1$ 1.00 - 1.50	$\emptyset D_1$ 1.50 - 2.00	$\emptyset D_1$ 2.00 - 3.00	$\emptyset D_1$ 3.00 - 4.00	
0.008 - 0.015	0.010 - 0.025	0.015 - 0.030	0.020 - 0.050	0.030 - 0.070	
0.005 - 0.012	0.008 - 0.020	0.013 - 0.025	0.020 - 0.045	0.025 - 0.060	
0.012 - 0.030	0.020 - 0.040	0.025 - 0.055	0.030 - 0.070	0.035 - 0.080	
0.002 - 0.011	0.008 - 0.015	0.012 - 0.023	0.015 - 0.038	0.023 - 0.060	
0.003 - 0.016	0.011 - 0.023	0.018 - 0.034	0.023 - 0.056	0.034 - 0.090	
0.002 - 0.009	0.007 - 0.014	0.011 - 0.020	0.014 - 0.034	0.020 - 0.054	
0.012 - 0.030	0.020 - 0.040	0.025 - 0.055	0.030 - 0.070	0.050 - 0.100	
0.005 - 0.012	0.008 - 0.020	0.013 - 0.025	0.020 - 0.045	0.025 - 0.060	
0.005 - 0.012	0.008 - 0.020	0.013 - 0.025	0.020 - 0.045	0.025 - 0.060	
0.001 - 0.007	0.005 - 0.010	0.008 - 0.015	0.010 - 0.025	0.015 - 0.040	
0.008 - 0.015	0.010 - 0.020	0.015 - 0.040	0.030 - 0.060	0.040 - 0.080	
0.015 - 0.035	0.020 - 0.040	0.025 - 0.050	0.030 - 0.070	0.050 - 0.100	
0.012 - 0.030	0.020 - 0.040	0.025 - 0.055	0.030 - 0.070	0.050 - 0.100	
0.015 - 0.035	0.020 - 0.040	0.025 - 0.055	0.030 - 0.070	0.050 - 0.100	
0.015 - 0.035	0.020 - 0.040	0.025 - 0.055	0.030 - 0.070	0.050 - 0.100	
0.015 - 0.035	0.020 - 0.040	0.025 - 0.055	0.030 - 0.070	0.050 - 0.100	
0.015 - 0.035	0.020 - 0.040	0.025 - 0.055	0.030 - 0.070	0.050 - 0.100	
0.015 - 0.035	0.020 - 0.040	0.025 - 0.055	0.030 - 0.070	0.050 - 0.100	



CONDITIONS DE COUPE

Matières à usiner

		DAC	
		Vc [m/min]	
N	Alliage de cuivre / bonne usinabilité (laiton – bronze)		200
N	Alliage de cuivre / usinabilité difficile / Bronze à l'aluminium (CuAlFe) (Ampco)		150
N	Alliage d'aluminium	Si < 8%	250
N	Fonte d'aluminium	Si > 8%	200
N	Graphite		200
N	Plastique		250
N	Or, argent		200

CONDITIONS DE COUPE

Matières à usiner

		CUTINOX	
		Vc [m/min]	
P	Acier non allié / faiblement allié	< 600 N/mm ²	150
P	Acier non allié / faiblement allié	600 – 1500 N/mm ²	120
P	Acier de décolletage au plomb		160
P	Acier fortement allié	700 – 1500 N/mm ²	70
M	Acier inoxydable	400 – 700 N/mm ²	90
M	Acier inox. DUPLEX, acier austénitique inox. sans nickel	> 800 N/mm ²	60
K	Fonte grise / Fonte à graphite sphéroïdal perlitique	< 250 HB	200
K	Fonte allié / Fonte à graphite sphéroïdal perlitique	> 250 HB	130
K	Fonte à graphite sphéroïdal ferritique / Fonte malléable		110
S	Super alliages / Acier inox. réfractaire	Inconel Nimonic Hastelloy	50
S	Titane, alliage de titane		60



$$n \text{ [tr/min]} = \frac{Vc \text{ [m/min]} \times 1000}{\pi \times D_1 \text{ [mm]}}$$

$$Vf \text{ [mm/min]} = n \text{ [tr/min]} \times fz \text{ [mm]} \times z$$

Avance centre outil

Vf [mm/min]

M5	M6	M8	M10
1000	1000	1000	1000
1000	1000	1000	1000
1000	1000	1000	1000
1000	1000	1000	1000
1000	1000	1000	1000
1000	1000	1000	1000
1000	1000	1000	1000

$$Vf \text{ centre outil} = Vf \times \left(1 - \frac{M}{D_1}\right)$$

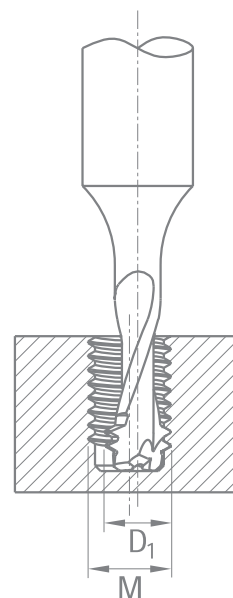

Avance centre outil

Vf [mm/min]

M5	M6	M8	M10
800	600	500	500
600	500	350	350
1200	1000	800	800
450	400	250	250
500	450	350	350
400	300	200	200
1000	800	500	500
600	500	350	350
550	450	300	300
250	200	150	150
300	250	200	200



CONDITIONS DE COUPE

Matières à usiner			CARBURE		TiALN	
			Vc [m/min]		Vc [m/min]	
P	Acier non allié / faiblement allié	< 600 N/mm ²	70	100	90	110
P	Acier non allié / faiblement allié	600 – 1500 N/mm ²			70	90
P	Acier de décolletage au plomb		70	100	90	110
P	Acier fortement allié	700 – 1500 N/mm ²			40	55
M	Acier inoxydable	400 – 700 N/mm ²	40	60	70	90
M	Acier inox. DUPLEX, acier austénitique inox. sans nickel	> 800 N/mm ²			40	55
K	Fonte grise / Fonte à graphite sphéroïdal perlitique	< 250 HB	70	100	90	110
K	Fonte alliée / Fonte à graphite sphéroïdal perlitique	> 250 HB	40	70	70	90
K	Fonte à graphite sphéroïdal ferritique / Fonte malléable		70	100	90	110
S	Titane, alliage de titane		30	45	40	60
N	Alliage de cuivre / bonne usinabilité (laiton – bronze)		140	160	200	220
N	Alliage de cuivre / usinabilité difficile / Bronze à l'aluminium	(CuAlFe) (Ampco)	120	140	170	190
N	Alliage d'aluminium	Si < 8%	180	260	230	340
N	Fonte d'aluminium	Si > 8%	140	160	210	230
N	Plastique		240	260	300	340
N	Or, argent		140	160	200	220



$$n \text{ [tr/min]} = \frac{Vc \text{ [m/min]} \times 1000}{\pi \times D_1 \text{ [mm]}}$$

$$Vf \text{ [mm/min]} = n \text{ [tr/min]} \times fz \text{ [mm]} \times z$$

Avance par dent **fz [mm]**

$\emptyset D_1$ 0.90 - 1.50	$\emptyset D_1$ 1.50 - 2.00	$\emptyset D_1$ 2.00 - 2.50	$\emptyset D_1$ 2.50 - 3.00	$\emptyset D_1$ 3.00 - 4.00	$\emptyset D_1$ 4.00 - 6.00	$\emptyset D_1$ 6.00 - 8.00	$\emptyset D_1$ 8.00 - 10.00	$\emptyset D_1$ 10.00 - 12.00	$\emptyset D_1$ 12.00 - 16.00
		0.008 - 0.02	0.010 - 0.02	0.012 - 0.03	0.016 - 0.04	0.024 - 0.06	0.03 - 0.07	0.04 - 0.08	0.05 - 0.11
		0.006 - 0.01	0.008 - 0.01	0.009 - 0.02	0.012 - 0.03	0.018 - 0.04	0.02 - 0.05	0.03 - 0.06	0.04 - 0.08
0.005 - 0.015	0.008 - 0.020	0.010 - 0.03	0.013 - 0.03	0.015 - 0.04	0.020 - 0.06	0.030 - 0.08	0.04 - 0.10	0.05 - 0.12	0.06 - 0.16
			0.008 - 0.01	0.009 - 0.02	0.012 - 0.03	0.018 - 0.04	0.02 - 0.05	0.03 - 0.06	0.04 - 0.08
		0.006 - 0.01	0.008 - 0.01	0.009 - 0.02	0.012 - 0.03	0.018 - 0.04	0.02 - 0.05	0.03 - 0.06	0.04 - 0.08
			0.008 - 0.01	0.009 - 0.02	0.012 - 0.03	0.018 - 0.04	0.02 - 0.05	0.03 - 0.06	0.04 - 0.08
		0.008 - 0.02	0.010 - 0.02	0.012 - 0.03	0.016 - 0.04	0.024 - 0.06	0.03 - 0.07	0.04 - 0.08	0.05 - 0.11
			0.008 - 0.01	0.009 - 0.02	0.012 - 0.03	0.018 - 0.04	0.02 - 0.05	0.03 - 0.06	0.04 - 0.08
	0.006 - 0.014	0.008 - 0.02	0.010 - 0.02	0.012 - 0.03	0.016 - 0.04	0.024 - 0.06	0.03 - 0.07	0.04 - 0.08	0.05 - 0.11
		0.006 - 0.01	0.008 - 0.01	0.009 - 0.02	0.012 - 0.03	0.018 - 0.04	0.02 - 0.05	0.03 - 0.06	0.04 - 0.08
0.005 - 0.015	0.008 - 0.020	0.010 - 0.03	0.013 - 0.03	0.015 - 0.04	0.020 - 0.06	0.030 - 0.08	0.04 - 0.10	0.05 - 0.12	0.06 - 0.16
0.003 - 0.008	0.005 - 0.010	0.006 - 0.01	0.008 - 0.01	0.009 - 0.02	0.012 - 0.03	0.018 - 0.04	0.02 - 0.05	0.03 - 0.06	0.04 - 0.08
0.005 - 0.015	0.008 - 0.020	0.010 - 0.03	0.013 - 0.03	0.015 - 0.04	0.020 - 0.06	0.030 - 0.08	0.04 - 0.10	0.05 - 0.12	0.06 - 0.16
0.005 - 0.015	0.008 - 0.020	0.010 - 0.03	0.013 - 0.03	0.015 - 0.04	0.020 - 0.06	0.030 - 0.08	0.04 - 0.10	0.05 - 0.12	0.06 - 0.16
0.006 - 0.023	0.011 - 0.030	0.014 - 0.04	0.018 - 0.04	0.021 - 0.06	0.028 - 0.09	0.042 - 0.12	0.06 - 0.15	0.07 - 0.18	0.08 - 0.24
0.005 - 0.015	0.008 - 0.020	0.010 - 0.03	0.013 - 0.03	0.015 - 0.04	0.020 - 0.06	0.030 - 0.08	0.04 - 0.10	0.05 - 0.12	0.06 - 0.16



CONDITIONS DE COUPE

Matières à usiner			CARBURE		TiALN	
			Vc [m/min]		Vc [m/min]	
P	Acier non allié / faiblement allié	< 600 N/mm ²	70	100	90	110
P	Acier non allié / faiblement allié	600 – 1500 N/mm ²	40	60	70	90
P	Acier de décolletage au plomb		70	100	90	110
P	Acier fortement allié	700 – 1500 N/mm ²	40	60	70	90
M	Acier inoxydable	400 – 700 N/mm ²	30	45	40	55
M	Acier inox. DUPLEX, acier austénitique inox. sans nickel	> 800 N/mm ²	40	60	70	90
K	Fonte grise / Fonte à graphite sphéroïdal perlitique	< 250 HB	70	100	90	110
K	Fonte alliée / Fonte à graphite sphéroïdal perlitique	> 250 HB	40	70	70	90
K	Fonte à graphite sphéroïdal ferritique / Fonte malléable		70	100	90	110
S	Titane, alliage de titane		30	45	40	60
N	Alliage de cuivre / bonne usinabilité (laiton – bronze)		140	160	200	220
N	Alliage de cuivre / usinabilité difficile / Bronze à l'aluminium	(CuAlFe) (Ampco)	120	140	170	190
N	Alliage d'aluminium	Si < 8%	180	260	230	270
N	Fonte d'aluminium	Si > 8%	140	160	210	230
N	Plastique		240	260	300	340
N	Or, argent		140	160	200	220



$$n \text{ [tr/min]} = \frac{Vc \text{ [m/min]} \times 1000}{\pi \times D_1 \text{ [mm]}}$$

$$Vf \text{ [mm/min]} = n \text{ [tr/min]} \times fz \text{ [mm]} \times z$$

Avance par dent **fz [mm]**

Ø D ₁ 0.90 - 1.50	Ø D ₁ 1.50 - 2.00	Ø D ₁ 2.00 - 2.50	Ø D ₁ 2.50 - 3.00	Ø D ₁ 3.00 - 4.00	Ø D ₁ 4.00 - 6.00	Ø D ₁ 6.00 - 8.00	Ø D ₁ 8.00 - 10.00	Ø D ₁ 10.00 - 12.00	Ø D ₁ 12.00 - 16.00
0.005 - 0.012	0.009 - 0.016	0.012 - 0.02	0.015 - 0.02	0.018 - 0.03	0.024 - 0.05	0.036 - 0.06	0.05 - 0.08	0.06 - 0.10	0.07 - 0.13
0.004 - 0.009	0.006 - 0.012	0.008 - 0.02	0.010 - 0.02	0.012 - 0.02	0.016 - 0.04	0.024 - 0.05	0.03 - 0.06	0.04 - 0.07	0.05 - 0.10
0.006 - 0.018	0.011 - 0.024	0.014 - 0.03	0.018 - 0.03	0.021 - 0.05	0.028 - 0.07	0.042 - 0.10	0.06 - 0.12	0.07 - 0.14	0.08 - 0.19
0.004 - 0.009	0.006 - 0.012	0.008 - 0.02	0.010 - 0.02	0.012 - 0.02	0.016 - 0.04	0.024 - 0.05	0.03 - 0.06	0.04 - 0.07	0.05 - 0.10
0.004 - 0.009	0.006 - 0.012	0.008 - 0.02	0.010 - 0.02	0.012 - 0.02	0.016 - 0.04	0.024 - 0.05	0.03 - 0.06	0.04 - 0.07	0.05 - 0.10
0.004 - 0.009	0.006 - 0.012	0.008 - 0.02	0.010 - 0.02	0.012 - 0.02	0.016 - 0.04	0.024 - 0.05	0.03 - 0.06	0.04 - 0.07	0.05 - 0.10
0.005 - 0.012	0.009 - 0.016	0.012 - 0.02	0.015 - 0.02	0.018 - 0.03	0.024 - 0.05	0.036 - 0.06	0.05 - 0.08	0.06 - 0.10	0.07 - 0.13
0.004 - 0.009	0.006 - 0.012	0.008 - 0.02	0.010 - 0.02	0.012 - 0.02	0.016 - 0.04	0.024 - 0.05	0.03 - 0.06	0.04 - 0.07	0.05 - 0.10
0.005 - 0.012	0.009 - 0.016	0.012 - 0.02	0.015 - 0.02	0.018 - 0.03	0.024 - 0.05	0.036 - 0.06	0.05 - 0.08	0.06 - 0.10	0.07 - 0.13
0.004 - 0.009	0.006 - 0.012	0.008 - 0.02	0.010 - 0.02	0.012 - 0.02	0.016 - 0.04	0.024 - 0.05	0.03 - 0.06	0.04 - 0.07	0.05 - 0.10
0.006 - 0.018	0.011 - 0.024	0.014 - 0.03	0.018 - 0.03	0.021 - 0.05	0.028 - 0.07	0.042 - 0.10	0.06 - 0.12	0.07 - 0.14	0.08 - 0.19
0.004 - 0.009	0.006 - 0.012	0.008 - 0.02	0.010 - 0.02	0.012 - 0.02	0.016 - 0.04	0.024 - 0.05	0.03 - 0.06	0.04 - 0.07	0.05 - 0.10
0.006 - 0.018	0.011 - 0.024	0.014 - 0.03	0.018 - 0.03	0.021 - 0.05	0.028 - 0.07	0.042 - 0.10	0.06 - 0.12	0.07 - 0.14	0.08 - 0.19
0.006 - 0.018	0.011 - 0.024	0.014 - 0.03	0.018 - 0.03	0.021 - 0.05	0.028 - 0.07	0.042 - 0.10	0.06 - 0.12	0.07 - 0.14	0.08 - 0.19
0.007 - 0.027	0.012 - 0.036	0.016 - 0.05	0.020 - 0.05	0.024 - 0.07	0.032 - 0.11	0.048 - 0.14	0.06 - 0.18	0.08 - 0.22	0.10 - 0.29
0.006 - 0.018	0.011 - 0.024	0.014 - 0.03	0.018 - 0.03	0.021 - 0.05	0.028 - 0.07	0.042 - 0.10	0.06 - 0.12	0.07 - 0.14	0.08 - 0.19



CONDITIONS DE COUPE

Matières à usiner			CARBURE		CUTINOX	
			Vc [m/min]		Vc [m/min]	
K	Fonte grise / Fonte à graphite sphéroïdal perlitique	< 250 HB	80	140	100	200
N	Alliage de cuivre / bonne usinabilité (laiton – bronze)		100	250	150	350
N	Alliage de cuivre / usinabilité difficile / Bronze à l'aluminium	(CuAlFe) (Ampco)	100	250	150	350
N	Alliage d'aluminium	Si < 8%	100	200	150	350
N	Fonte d'aluminium	Si > 8%			150	350



$$n \text{ [tr/min]} = \frac{Vc \text{ [m/min]} \times 1000}{\pi \times D_1 \text{ [mm]}}$$

PERÇAGE

$$Vf \text{ [mm/min]} = n \text{ [tr/min]} \times f \text{ [mm]}$$

Avance par tour (f)

$\emptyset D_1$ 3.00 - 700	$\emptyset D_1$ 7.00 - 14.00
0.08 - 0.24	0.18 - 0.40
0.08 - 0.18	0.14 - 0.30
0.14 - 0.28	0.18 - 0.40
0.14 - 0.28	0.18 - 0.40
0.14 - 0.28	0.18 - 0.40

FILETAGE

$$Vf \text{ [mm/min]} = n \text{ [tr/min]} \times fz \text{ [mm]} \times z$$

Avance par dent (fz)

$\emptyset D_1$ 3.00 - 700	$\emptyset D_1$ 7.00 - 14.00
0.03 - 0.07	0.05 - 0.12
0.04 - 0.07	0.06 - 0.15
0.04 - 0.07	0.05 - 0.15
0.03 - 0.07	0.06 - 0.15
0.03 - 0.07	0.06 - 0.15

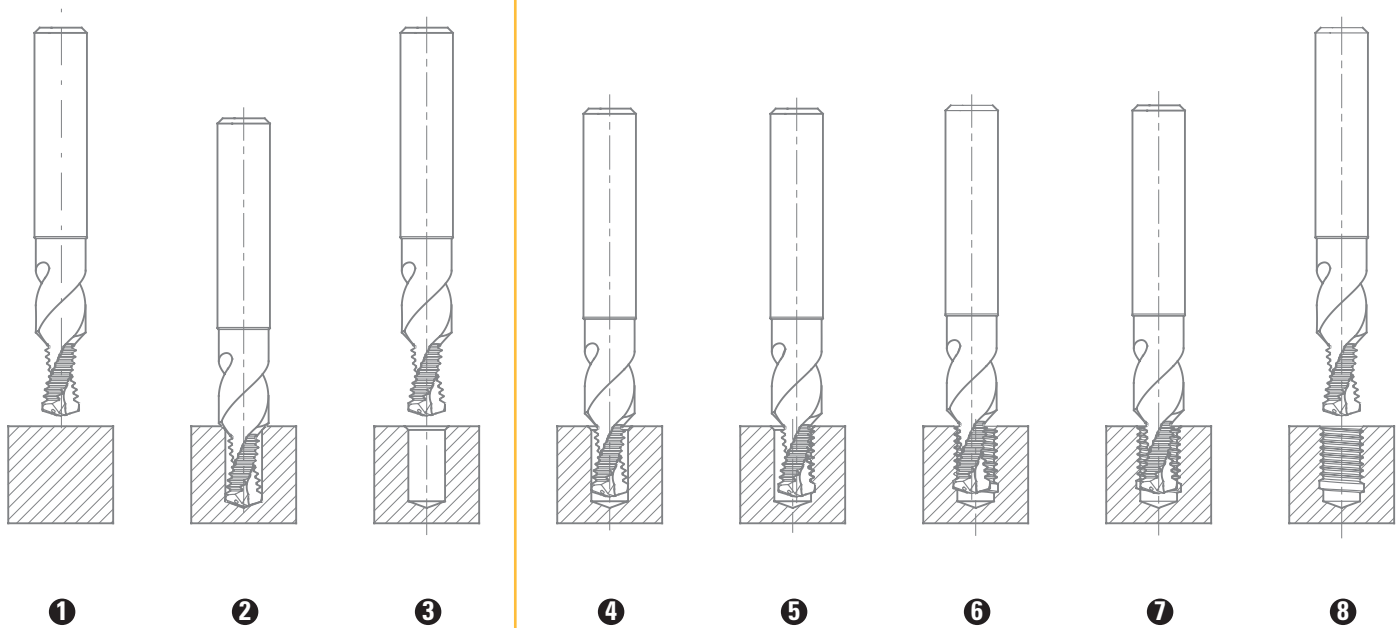



ALÉSAGE

REIBEN

REAMING

ALESATURA

FURAT

SÉLECTION DES OUTILS À ALÉSER ET ALÉSOIRS **334**



OUTILS À ALÉSER ET CHANFREINER **336**



OUTILS À ALÉSER **338**



ALÉSOIRS **343**





CONDITIONS DE COUPE **346**



OUTILS SUR DEMANDE **349**

SELECTION DES ALÉSOIRS ET OUTILS À ALÉSER

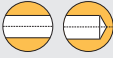
✓ = article de stock

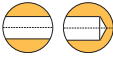
		Z	Page		<input type="checkbox"/> CARBURE				
OUTILS À ALÉSER ET CHANFREINER									
DIXI 2577 Ø 0.26 - 0.86		-	336		✓				
DIXI 2567 Ø 0.20 - 1.00		-	337		✓				

OUTILS À ALÉSER

DIXI 2578 Ø 0.30 - 1.00		-	338		✓				
DIXI 2579 Ø 0.60 - 3.00		-	339		✓				
DIXI 2580 Ø 0.50 - 20.00		-	339		✓				
DIXI 2581 Ø 0.50 - 18.00		-	341		✓				
DIXI 2764		-	338						

ALÉSOIRS

POLY 4001 Ø 0.40 - 12.02		3 - 6	343		✓				
POLY 4005 Ø 2.97 - 6.50		4 - 6	344		✓				
POLY 4007 Ø 0.37 - 12.02		3 - 6	345		✓				

Pour tous les autres types d'alésors, voir notre catalogue POLYTOOL



○ bien ⊙ excellent

Acier + Pb	Acier > 600MPa	Aciers fort. allié	Acier inox aust.	Aciers Fontes 45-65 HRC	Fontes	Super alliages Ni / Co	Titane, alliages de titane	Alliage Cu Argent Or	Alliage Cu difficile	Alu	Graphite	Plastique
------------	----------------	--------------------	------------------	-------------------------	--------	------------------------	----------------------------	----------------------	----------------------	-----	----------	-----------

⊙	⊙	○	○		⊙	○	⊙	⊙	⊙	⊙		⊙
⊙	⊙	○	○		⊙	○	⊙	⊙	⊙	⊙		⊙

⊙	⊙	○	○		⊙	○	⊙	⊙	⊙	⊙		⊙
⊙	⊙	○	○		⊙	○	⊙	⊙	⊙	⊙		⊙
⊙	⊙	○	○		⊙	○	⊙	⊙	⊙	⊙		⊙
⊙	⊙	○	○		⊙	○	⊙	⊙	⊙	⊙		⊙

⊙	⊙	○	○		⊙	○	⊙	⊙	⊙	⊙		⊙
⊙	⊙	○	○		⊙	○	⊙	⊙	⊙	⊙		⊙
⊙	⊙	○	○		⊙	○	⊙	⊙	⊙	⊙		⊙



OUTILS À ALÉSER ET CHANFREINER

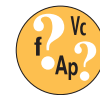

P. 348

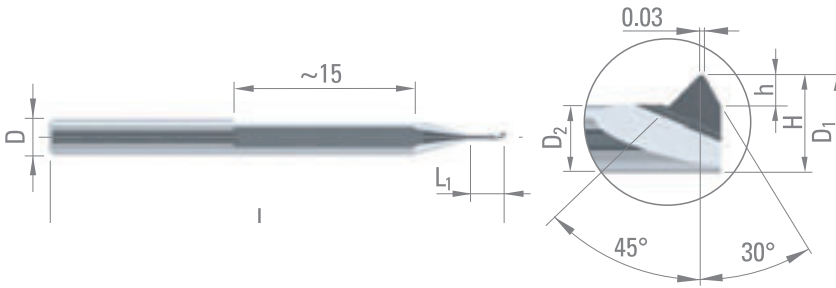
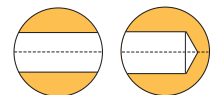

Acier + Pb	Acier > 600MPa	Acier fort. allié	Acier inox aust.	Fontes
Super alliages Ni / Co	Titane, alliage de titane	Alliage Cu Argent Or	Alliage Cu difficile	Alu
Plastique				

pour...	D ₁	L ₁	D ₂	h	H	D _{h5}	L	CARBURE
S 0.30	0.26	0.84	0.14	0.06	0.20	3	46	968880
S 0.40	0.35	1.04	0.21	0.07	0.28	3	46	969086
S 0.50	0.44	1.35	0.28	0.08	0.36	3	46	969087
S 0.60	0.53	1.66	0.33	0.10	0.43	3	46	969088
S 0.70	0.66	2.04	0.36	0.15	0.51	3	46	969089
S 0.80	0.75	2.30	0.43	0.16	0.58	3	46	969090
S 0.90	0.86	2.72	0.46	0.20	0.66	3	46	969091

Alésage trou borgne

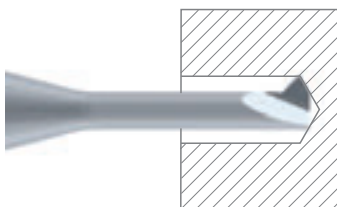

Alésage trou passant

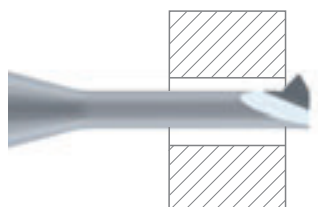

Anglage

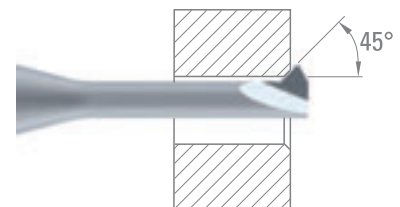

tasseaux p. 338



BURINS À ALÉSER ET CHANFREINER



P. 348

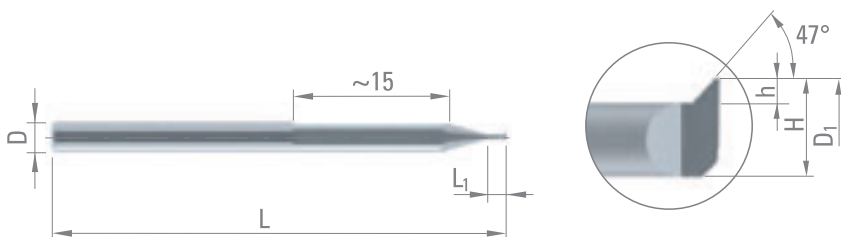
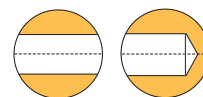

Acier + Pb	Acier > 600MPa	Acier fort. allié	Acier inox aust.	Fontes
Super alliages Ni / Co	Titane, alliage de titane	Alliage Cu Argent Or	Alliage Cu difficile	Alu
Plastique				

D ₁	L ₁	h	H	D _{h5}	L	CARBURE
0.20	0.2	0.04	0.16	3	46	997972
	0.4					997973
0.30	0.3	0.06	0.24	3	46	997974
	0.6					997975
0.40	0.4	0.08	0.32	3	46	997976
	0.8					997977
0.50	0.5	0.10	0.40	3	46	997978
	1.0					997979
0.60	0.6	0.12	0.48	3	46	997980
	1.2					997981
0.70	0.7	0.14	0.56	3	46	997982
	1.4					997983
0.80	0.8	0.16	0.64	3	46	997984
	1.6					997985
0.90	0.9	0.18	0.72	3	46	997986
	1.8					997987
1.00	1.0	0.20	0.80	3	46	997988
	2.0					997989

Alésage trou borgne

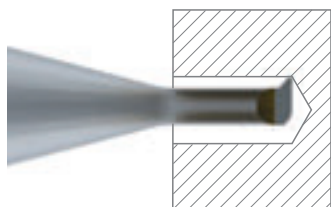

Alésage trou passant

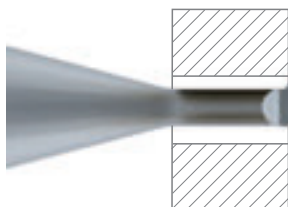

Anglage

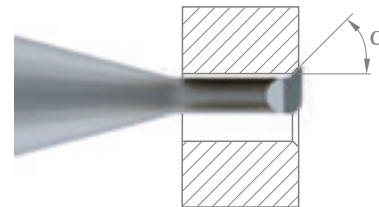

tasseaux p. 338



DIXI 2578

BURINS À ALÉSER



P. 348

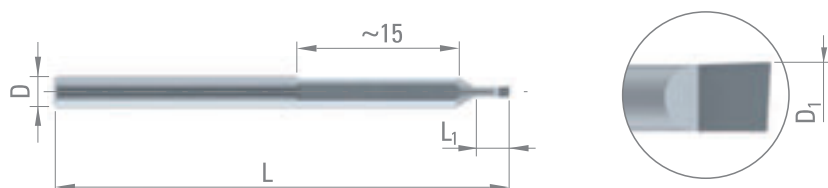
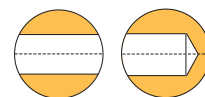

Acier + Pb	Acier > 600MPa	Acier fort. allié	Acier inox aust.	Fontes
Super alliages Ni / Co	Titane, alliage de titane	Alliage Cu Argent Or	Alliage Cu difficile	Alu
Plastique				

D ₁	L ₁	D _{h5}	L	CARBURE
0.30	0.6	3	46	997948
	0.9			997949
	1.2			997950
0.40	0.8	3	46	997951
	1.2			997952
	1.6			997953
0.50	1.0	3	46	997954
	1.5			997955
	2.0			997956
0.60	1.2	3	46	997957
	1.8			997958
	2.4			997959
0.70	1.4	3	46	997960
	2.1			997961
	2.8			997962
0.80	1.6	3	46	997963
	2.4			997964
	3.6			997965
0.90	1.8	3	46	997966
	2.7			997967
	3.6			997968
1.00	2.0	3	46	997969
	3.0			997970
	4.0			997971

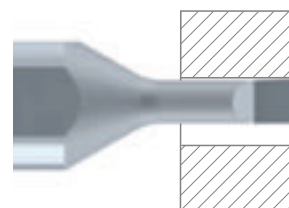
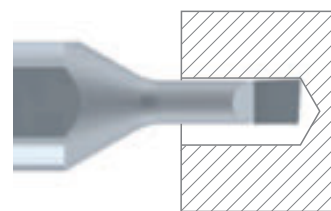

DIXI 2764

PORTE-BURINS

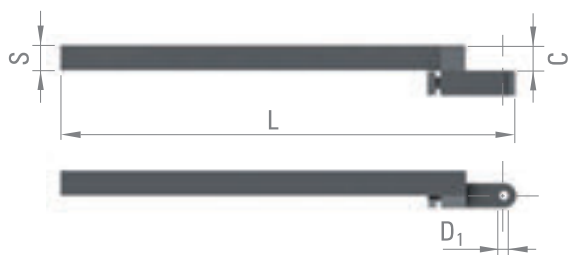

S	L	D ₁	C	Art.
7 x 7	146	3	7	305008
8 x 8	146	3	8	305009
10 x 10	150	3	10	305010



DIXI 2579

OUTILS À ALÉSER



P. 348

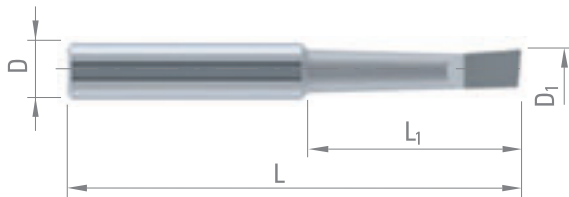
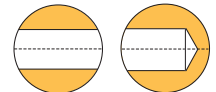

Acier + Pb	Acier > 600MPa	Acier fort. allié	Acier inox aust.	Fontes
Super alliages Ni / Co	Titane, alliage de titane	Alliage Cu Argent Or	Alliage Cu difficile	Alu
Plastique				

D ₁	L ₁	D _{h5}	L	CARBURE
0.60	3	4	25	53197
0.80	4	4	25	53198
1.00	5	4	25	53199
1.20	6	4	25	53200
1.50	8	4	32	53201
1.80	9	4	32	53202
2.00	10	4	32	53203
2.50	12	4	32	53204
3.00	15	4	32	53205

DIXI 2580

OUTILS À ALESER TROU BORGNE



P. 348

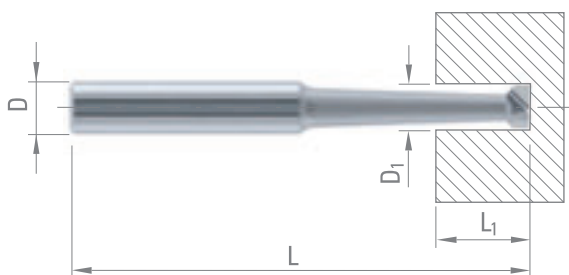
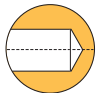

Acier + Pb	Acier > 600MPa	Acier fort. allié	Acier inox aust.	Fontes
Super alliages Ni / Co	Titane, alliage de titane	Alliage Cu Argent Or	Alliage Cu difficile	Alu
Plastique				

D ₁	L ₁	D _{h5}	L	CARBURE
0.50	3	4	25	36091
0.80	4	4	25	36092
1.00	4	4	25	33855
1.20	6	4	25	33856
1.50	7	4	28	33857
1.70	7	4	28	33858





D ₁	L ₁	D _{h5}	L	CARBURE
2.00	9	4	30	33859
2.20	9	4	30	33860
2.50	12	4	33	33861
3.00	14	4	35	33862
3.50	14	4	35	33863
4.00	17	4	38	33864
5.00	23	4	38	794
2.00	9	6	38	33865
2.50	12	6	40	33866
3.00	14	6	42	33867
4.00	17	6	45	33868
5.00	22	6	52	795
6.00	24	6	52	796
7.00	30	6	52	797
8.00	32	6	52	798
10.00	40	6	60	800
3.00	17	8	47	790
4.00	21	8	51	791
5.00	22	8	52	801
6.00	25	8	55	802
7.00	28	8	60	803
10.00	45	8	65	804
12.00	54	8	70	805
13.00	54	8	78	5603
3.00	17	10	45	792
4.00	21	10	49	793
5.00	22	10	50	806
6.00	25	10	54	807
7.00	28	10	56	808
9.00	32	10	65	809
10.00	32	10	65	810
12.00	45	10	70	811
13.00	55	10	80	812
15.00	75	10	100	813
18.00	75	10	100	814
8.00	30	12	70	815
10.00	40	12	80	816
13.00	60	12	90	817
15.00	70	12	100	818
18.00	70	12	100	819
13.00	60	16	115	820
15.00	60	16	115	821
18.00	75	16	115	822
20.00	75	16	115	824

Acier + Pb	Acier > 600MPa	Acier fort. allié	Acier inox aust.	Fontes
Super alliages Ni / Co	Titane, alliage de titane	Alliage Cu Argent Or	Alliage Cu difficile	Alu
Plastique				

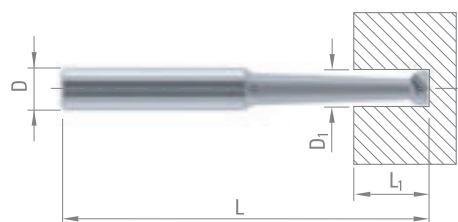

OUTILS À ALÉSER TROU PASSANT



P. 348

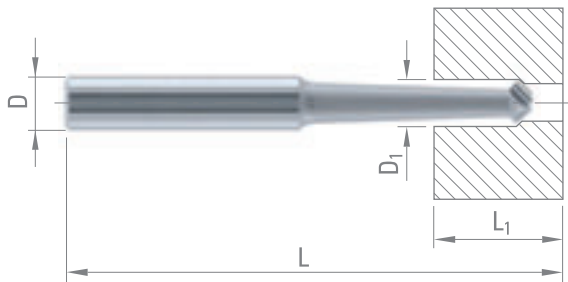
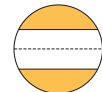

Acier + Pb	Acier > 600MPa	Acier fort. allié	Acier inox aust.	Fontes
Super alliages Ni / Co	Titane, alliage de titane	Alliage Cu Argent Or	Alliage Cu difficile	Alu
Plastique				

D ₁	L ₁	D _{h5}	L	CARBURE
0.50	3	4	25	36093
0.80	4	4	25	36094
1.00	4	4	25	33869
1.20	6	4	25	33870
1.50	7	4	28	33871
1.70	7	4	28	33872
2.00	9	4	30	33873
2.20	9	4	30	33874
2.50	12	4	33	33875
3.00	14	4	35	33876
3.50	14	4	35	33877
4.00	17	4	38	33878
5.00	23	4	38	745
2.00	9	6	38	33879
2.50	12	6	40	33880
3.00	14	6	42	33881
4.00	17	6	45	33882
5.00	22	6	52	746
6.00	24	6	52	747
8.00	32	6	52	749
10.00	40	6	60	751
3.00	17	8	47	740
4.00	21	8	51	741
5.00	22	8	52	752
6.00	25	8	55	753
7.00	28	8	60	754
9.00	45	8	65	755
11.00	54	8	70	756
13.00	54	8	78	5661





P. 348

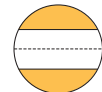

D_1	L_1	D_{h5}	L	CARBURE
3.00	17	10	45	742
4.00	21	10	49	743
5.00	22	10	50	757
6.00	25	10	54	758
7.00	28	10	56	759
9.00	32	10	65	760
10.00	32	10	65	761
12.00	45	10	70	762
13.00	55	10	80	763
15.00	75	10	100	764
18.00	75	10	100	765
8.00	30	12	70	766
10.00	40	12	80	767
13.00	60	12	90	768
15.00	70	12	100	769
18.00	70	12	100	770
20.00	80	12	110	825
13.00	60	16	115	771
15.00	60	16	115	772
18.00	75	16	115	773

Acier + Pb	Acier > 600MPa	Acier fort. allié	Acier inox aust.	Fontes
Super alliages Ni / Co	Titane, alliage de titane	Alliage Cu Argent Or	Alliage Cu difficile	Alu
Plastique				

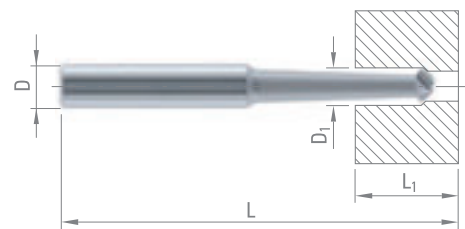

POLY 4001

ALÉSOIRS DENTURE IRRÉGULIÈRE DROITE



P. 346



> Ø 2.98



Ref. A

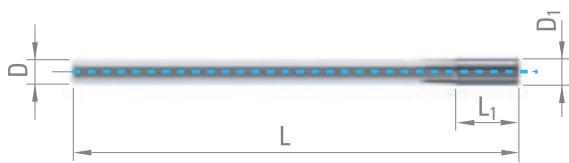

Ref. B

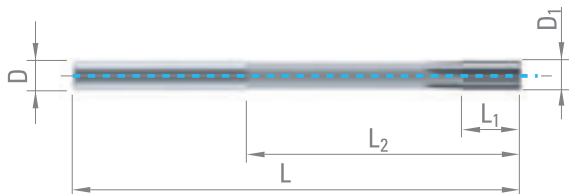

Acier + Pb	Acier > 600MPa	Acier fort. allié	Acier inox aust.	Fontes
Super alliages Ni / Co	Titane, alliage de titane	Alliage Cu Argent Or	Alliage Cu difficile	Alu
Plastique				

D _{1H7}	L ₁	L ₂	D _{h5}	L	Z	Ref.	CARBURE
0.40 - 0.50	3.0	5	3.0	38	3	B	☐
0.51 - 0.60	4.0	6	3.0	38	3	B	☐
0.61 - 0.70	4.0	7	3.0	38	3	B	☐
0.71 - 0.80	4.0	8	3.0	38	3	B	☐
0.81 - 0.90	5.0	9	3.0	38	3	B	☐
0.91 - 1.00	5.0	10	3.0	38	3	B	☐
1.01 - 1.08	5.0	11	3.0	38	3	B	☐
1.09 - 1.20	5.0	12	3.0	38	3	B	☐
1.21 - 1.40	6.0	13	3.0	38	3	B	☐
1.41 - 1.50	7.0	15	3.0	38	3	B	☐
1.51 - 1.60	7.0	15	3.0	50	3	B	☐
1.61 - 1.70	7.0	16	3.0	50	3	B	☐
1.71 - 1.80	7.0	17	3.0	50	3	B	☐
1.81 - 1.90	8.0	17	3.0	50	3	B	☐
1.91 - 2.30	8.0	18	3.0	50	3	B	☐
2.31 - 2.50	10.0	20	3.0	50	3	B	☐
2.51 - 2.60	10.0	20	3.0	61	4	B	☐
2.61 - 2.97	10.0	25	3.0	61	4	B	☐
2.98 - 3.02	10.0	25	3.0	65	4	B	☐
3.03 - 3.08	10.0	25	3.0	70	4	B	☐
3.09 - 3.52	10.0	-	3.0	70	4	A	☐
3.53 - 3.57	10.0	25	3.5	75	4	B	☐
3.58 - 4.02	10.0	-	3.5	75	4	A	☐
4.03 - 4.09	12.0	40	4.0	80	6	B	☐
4.10 - 4.52	12.0	-	4.0	80	6	A	☐
4.53 - 4.57	12.0	50	4.5	86	6	B	☐
4.58 - 5.03	12.0	-	4.5	86	6	A	☐
5.04 - 5.08	12.0	57	5.0	93	6	B	☐
5.09 - 5.79	12.0	-	5.0	93	6	A	☐
5.80 - 6.00	12.0	57	6.0	93	6	B	☐
6.01 - 6.70	14.0	63	6.0	101	6	B	☐
6.71 - 7.30	16.0	69	7.0	109	6	B	☐
7.31 - 7.50	16.0	69	8.0	117	6	B	☐
7.51 - 8.40	16.0	75	8.0	117	6	B	☐
8.42 - 8.50	16.0	75	8.0	125	6	B	☐
8.51 - 9.48	19.0	81	9.0	125	6	B	☐
9.49 - 9.50	19.0	81	9.0	133	6	B	☐
9.51 - 10.60	19.0	87	10.0	133	6	B	☐
10.61 - 11.80	19.0	96	12.0	142	6	B	☐
11.81 - 12.02	19.0	105	12.0	151	6	B	☐

Tous les 0.01 mm de stock

Tout Ø avec tolérance ±2µm livrable sur demande via notre service rapide

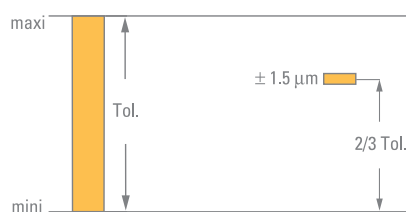

POLY 4005

ALÉSOIRS HÉLICOÏDAUX,
HÉLICE À DROITE, COUPE À DROITE

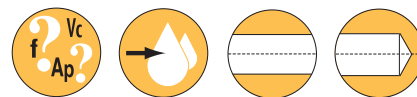

P. 346

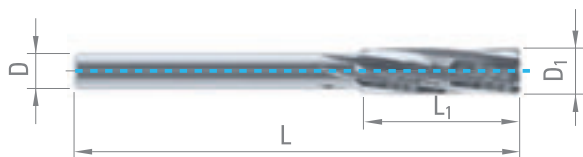

Acier + Pb	Acier > 600MPa	Acier fort. allié	Acier inox aust.	Fontes
Super alliages Ni / Co	Titane, alliage de titane	Alliage Cu Argent Or	Alliage Cu difficile	Alu
Plastique				

D_{1H7}	L_1	D_{h5}	L	Z	CARBURE
2.97 - 3.49	20.0	2.5	56	4	<input type="checkbox"/>
3.50 - 4.00	20.0	3.0	56	4	<input type="checkbox"/>
4.10 - 4.40	22.0	3.5	63	6	<input type="checkbox"/>
4.50 - 5.40	22.0	4.0	63	6	<input type="checkbox"/>
5.50 - 6.50	22.0	5.0	63	6	<input type="checkbox"/>

Tous les 0.01 mm de stock

Tout Ø avec tolérance $\pm 2\mu\text{m}$ livrable sur demande
via notre service rapide

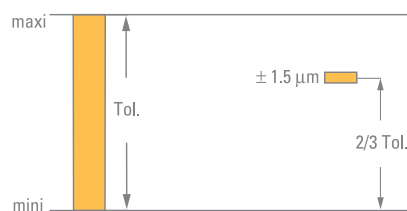

POLY 4007

ALÉSOIRS HÉLICOÏDAUX HÉLICE À GAUCHE, COUPE À DROITE



P. 346



> Ø 2.98



Ref. A

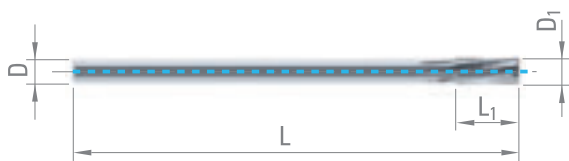

Ref. B

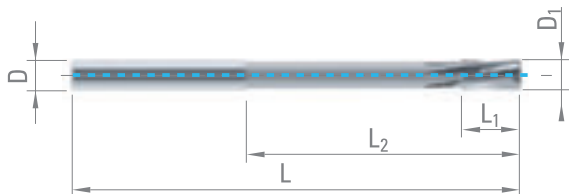

Acier + Pb	Acier > 600MPa	Acier fort. allié	Acier inox aust.	Fontes
Super alliages Ni / Co	Titane, alliage de titane	Alliage Cu Argent Or	Alliage Cu difficile	Alu
Plastique				

D ₁ 0/+0.003	L ₁	L ₂	D _{h5}	L	Z	Ref.	CARBURE
0.37 - 0.50	3.0	5	3.0	38	3	B	<input type="checkbox"/>
0.51 - 0.60	4.0	6	3.0	38	3	B	<input type="checkbox"/>
0.61 - 0.70	4.0	7	3.0	38	3	B	<input type="checkbox"/>
0.71 - 0.80	4.0	8	3.0	38	3	B	<input type="checkbox"/>
0.81 - 0.90	5.0	9	3.0	38	3	B	<input type="checkbox"/>
0.91 - 1.00	5.0	10	3.0	38	3	B	<input type="checkbox"/>
1.01 - 1.08	5.0	11	3.0	38	3	B	<input type="checkbox"/>
1.09 - 1.20	5.0	12	3.0	38	3	B	<input type="checkbox"/>
1.21 - 1.40	6.0	13	3.0	38	3	B	<input type="checkbox"/>
1.41 - 1.50	7.0	15	3.0	38	3	B	<input type="checkbox"/>
1.51 - 1.60	7.0	15	3.0	50	3	B	<input type="checkbox"/>
1.61 - 1.70	7.0	16	3.0	50	3	B	<input type="checkbox"/>
1.71 - 1.80	7.0	17	3.0	50	3	B	<input type="checkbox"/>
1.81 - 1.90	8.0	17	3.0	50	3	B	<input type="checkbox"/>
1.91 - 2.30	8.0	18	3.0	50	3	B	<input type="checkbox"/>
2.31 - 2.50	10.0	20	3.0	50	3	B	<input type="checkbox"/>
2.51 - 2.60	10.0	20	3.0	61	4	B	<input type="checkbox"/>
2.61 - 2.97	10.0	25	3.0	61	4	B	<input type="checkbox"/>
2.98 - 3.02	10.0	25	3.0	65	4	B	<input type="checkbox"/>
3.03 - 3.06	10.0	25	3.0	70	4	B	<input type="checkbox"/>
3.07 - 3.52	10.0	-	3.0	70	4	A	<input type="checkbox"/>
3.53 - 3.57	10.0	25	3.5	75	4	B	<input type="checkbox"/>
3.58 - 4.02	10.0	-	3.5	75	4	A	<input type="checkbox"/>
4.03 - 4.05	12.0	40	4.0	80	6	B	<input type="checkbox"/>
4.06 - 4.52	12.0	-	4.0	80	4	A	<input type="checkbox"/>
4.53 - 4.55	12.0	50	4.5	86	6	B	<input type="checkbox"/>
4.56 - 5.03	12.0	-	4.5	86	6	A	<input type="checkbox"/>
5.04 - 5.05	12.0	57	5.0	93	6	B	<input type="checkbox"/>
5.06 - 5.75	12.0	-	5.0	93	6	A	<input type="checkbox"/>
5.76 - 6.00	12.0	57	6.0	93	6	B	<input type="checkbox"/>
6.01 - 6.70	14.0	63	6.0	101	6	B	<input type="checkbox"/>
6.71 - 7.30	16.0	69	7.0	109	6	B	<input type="checkbox"/>
7.31 - 7.50	16.0	69	8.0	117	6	B	<input type="checkbox"/>
7.51 - 8.49	16.0	75	8.0	117	6	B	<input type="checkbox"/>
8.50 - 8.52	16.0	75	8.0	125	6	B	<input type="checkbox"/>
8.53 - 9.52	19.0	81	9.0	125	6	B	<input type="checkbox"/>
9.53 - 10.60	19.0	87	10.0	133	6	B	<input type="checkbox"/>
10.61 - 11.80	19.0	96	12.0	142	6	B	<input type="checkbox"/>
11.81 - 12.02	19.0	105	12.0	151	6	B	<input type="checkbox"/>

Tous les 0.01 mm de stock

Tout Ø avec tolérance ±2µm livrable sur demande
via notre service rapide



CONDITIONS DE COUPE

Matières à usiner

Matières à usiner		CARBURE	
		Vc [m/min]	
P	Acier non allié / faiblement allié	< 600 N/mm ²	14
			16
			20
P	Acier non allié / faiblement allié	600 – 1500 N/mm ²	12
			14
			16
P	Acier de décolletage au plomb		25
			50
			70
P	Acier fortement allié	700 – 1500 N/mm ²	8
			10
			12
M	Acier inoxydable	400 – 700 N/mm ²	10
			12
			16
M	Acier inox. DUPLEX, acier austénitique inox. sans nickel	> 800 N/mm ²	8
			10
			12
K	Fonte grise / Fonte à graphite sphéroïdal perlitique	< 250 HB	20
			30
			40
K	Fonte alliée / Fonte à graphite sphéroïdal perlitique	> 250 HB	12
			18
			24
K	Fonte à graphite sphéroïdal ferritique / Fonte malléable		14
			20
			32
S	Super alliages / Acier inox. réfractaire	Inconel Nimonic Hastelloy	8
			10
			12
S	Titane, alliage de titane		10
			12
			16
N	Alliage de cuivre / bonne usinabilité (laiton – bronze)		20
			30
			40
N	Alliage de cuivre / usinabilité difficile / Bronze à l'aluminium	(CuAlFe) (Ampco)	16
			24
			30
N	Alliage d'aluminium	Si < 8%	20
			40
			60
N	Fonte d'aluminium	Si > 8%	20
			36
			50
N	Plastique		20
			40
			60
N	Plastique avec fibres		10
			20
			30
N	Or, argent		20
			30
			40



$$n \text{ [tr/min]} = \frac{Vc \text{ [m/min]} \times 1000}{\pi \times D_1 \text{ [mm]}}$$

$$Vf \text{ [mm/min]} = n \text{ [tr/min]} \times f \text{ [mm]}$$

Avance par tour **f [mm]**

Ø D ₁ < 2.00	Ø D ₁ 2.00 - 4.03	Ø D ₁ 4.03 - 7.51	Ø D ₁ 7.51 - 12.02
0.05	0.10	0.30	0.40
0.15	0.20	0.50	0.60
0.20	0.30	0.70	0.80
0.05	0.10	0.25	0.30
0.15	0.20	0.40	0.50
0.20	0.30	0.65	0.70
0.05	0.20	0.40	0.60
0.15	0.40	0.60	0.80
0.20	0.50	0.80	1.00
0.05	0.10	0.20	0.30
0.15	0.15	0.30	0.40
0.20	0.25	0.40	0.50
0.05	0.10	0.20	0.30
0.15	0.15	0.30	0.40
0.20	0.20	0.40	0.50
0.05	0.10	0.20	0.30
0.15	0.15	0.30	0.40
0.20	0.25	0.40	0.50
0.05	0.10	0.40	0.60
0.15	0.15	0.50	0.70
0.20	0.25	0.60	0.80
0.05	0.10	0.30	0.40
0.15	0.15	0.40	0.50
0.20	0.20	0.50	0.60
0.05	0.10	0.30	0.40
0.15	0.20	0.40	0.50
0.20	0.30	0.50	0.60
0.05	0.10	0.20	0.30
0.15	0.15	0.30	0.40
0.20	0.20	0.40	0.50
0.05	0.10	0.30	0.40
0.15	0.20	0.40	0.50
0.20	0.30	0.50	0.60
0.05	0.10	0.40	0.60
0.20	0.25	0.60	0.80
0.30	0.40	0.80	1.00
0.05	0.10	0.40	0.60
0.20	0.25	0.60	0.80
0.30	0.40	0.80	1.00
0.05	0.10	0.40	0.50
0.20	0.25	0.50	0.60
0.30	0.40	0.60	0.70
0.05	0.10	0.30	0.40
0.20	0.25	0.40	0.50
0.30	0.40	0.50	0.60
0.05	0.10	0.40	0.60
0.15	0.20	0.60	0.80
0.20	0.30	0.80	1.00

0.05	0.10	0.10	0.10	Surépaisseur Ø [mm]
0.10	0.15	0.15	0.15	
0.15	0.20	0.20	0.20	



CONDITIONS DE COUPE

$$n \text{ [tr/min]} = \frac{Vc \text{ [m/min]} \times 1000}{\pi \times D_1 \text{ [mm]}}$$

$$Vf \text{ [mm/min]} = n \text{ [tr/min]} \times f \text{ [mm]}$$

Matières à usiner			Outil fixe Vc [m/min]	Outil tournant Vc [m/min]	Avance f [mm/tr]
P	Acier non allié / faiblement allié	< 600 N/mm ²	100 - 150	70 - 120	0.05 - 0.15
P	Acier non allié / faiblement allié	600 – 1500 N/mm ²	70 - 120	50 - 90	0.04 - 0.10
P	Acier de décolletage au plomb		120 - 160	90 - 130	0.05 - 0.15
P	Acier fortement allié	700 – 1500 N/mm ²	30 - 70	20 - 50	0.03 - 0.10
M	Acier inoxydable	400 – 700 N/mm ²	60 - 80	40 - 60	0.04 - 0.10
M	Acier inox. DUPLEX, acier austénitique inox. sans nickel	> 800 N/mm ²	30 - 70	20 - 50	0.03 - 0.10
K	Fonte grise / Fonte à graphite sphéroïdal perlitique	< 250 HB	60 - 150	40 - 120	0.05 - 0.15
K	Fonte alliée / Fonte à graphite sphéroïdal perlitique	> 250 HB	20 - 80	15 - 50	0.04 - 0.10
K	Fonte à graphite sphéroïdal ferritique / Fonte malléable		30 - 90	20 - 60	0.03 - 0.10
S	Super alliages / Acier inox. réfractaire	Inconel Nimonic Hastelloy	10 - 20	8 - 15	0.03 - 0.10
S	Titane, alliage de titane		15 - 30	10 - 25	0.03 - 0.10
N	Alliage de cuivre / bonne usinabilité (laiton – bronze)		150 - 250	120 - 180	0.08 - 0.20
N	Alliage de cuivre / usinabilité difficile / Bronze à l'aluminium (CuAlFe) (Ampco)		120 - 160	100 - 140	0.04 - 0.10
N	Alliage d'aluminium	Si < 8%	200 - 400	150 - 300	0.05 - 0.15
N	Fonte d'aluminium	Si > 8%	180 - 350	150 - 250	0.05 - 0.155
N	Plastique		200 - 300	150 - 250	0.10 - 0.30
N	Or, argent		150 - 250	120 - 180	0.08 - 0.20





POLY 4001 SP

Z =

Quantités

Dimensions et tolérance
du trou à usiner

Matière à usiner

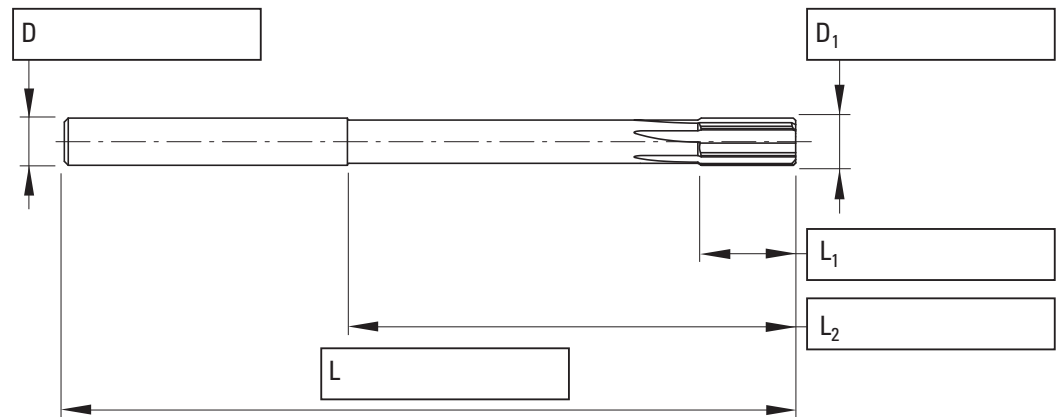

POLY 4007 SP

Z =

Quantités

Dimensions et tolérance
du trou à usiner

Matière à usiner

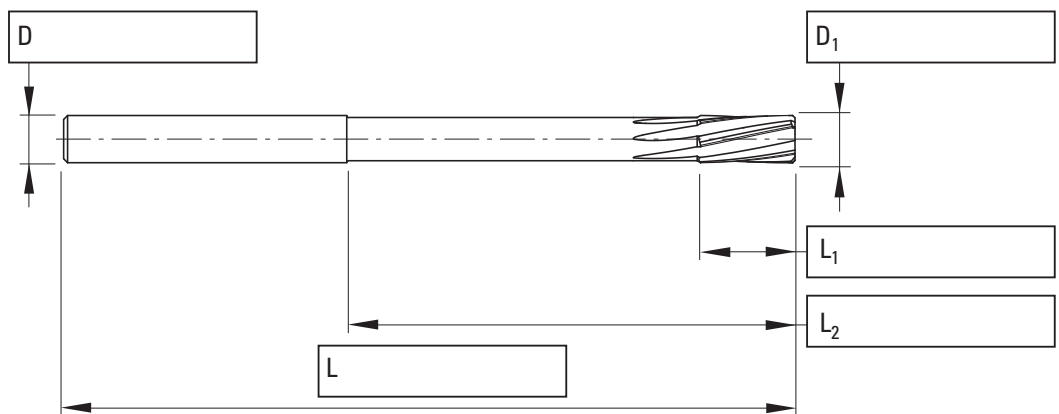

POLY 4005 SP

Z =

Quantités

Dimensions et tolérance
du trou à usiner

Matière à usiner

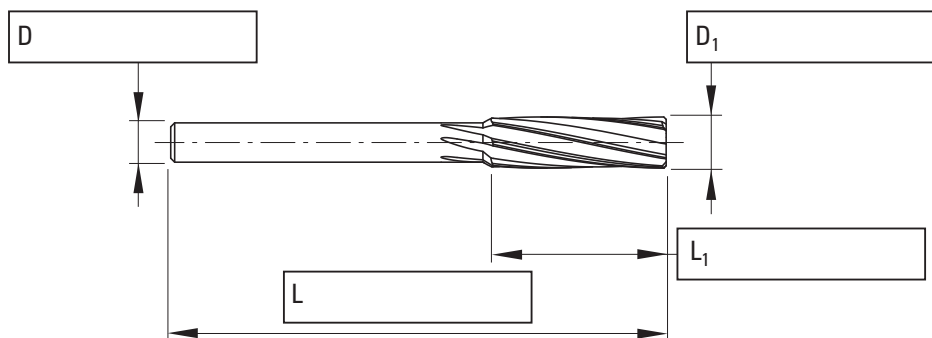



DIAMANT

DIAMANT



DIAMOND



DIAMANTE



GYÉMÁNT



352



358



364



365



366



368



369



370

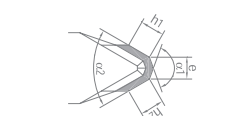

371



375



377

380

	Z			●	■	◆	▲	
DIXI 72420 Ø 2.00 - 20.00 	1 - 2	358		✓	✓		□	
DIXI 70520 PCD Ø 1.00 - 20.00 	1 - 2	359		✓	□		□	
DIXI 70600 PCD Ø 1.00 - 6.00 	1	360		✓				
DIXI 70600 DIA Ø 3.00 - 6.00 	1	360				✓		
DIXI 72310 DIA Ø 0.30 - 2.00 	1	361				✓		
DIXI 72421 DIA Ø 6.00 - 12.00 	1	362				✓		
DIXI 70320 PCD Ø 2.00 - 20.00 	1 - 2	363		✓	□		□	
DIXI 76230 DIA Ø 0.10 - 0.30 	1	364				✓		
DIXI 76230 	1	364		□	□		□	
DIXI 70170 DIA DIXI 70180 DIA Ø 0.05 - 0.10 	1	365				✓		
DIXI 70170 PCD DIXI 70180 PCD Ø 0.10 - 0.20 	1	365		✓				

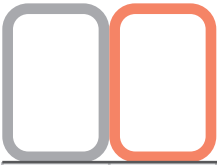

⊙	○
⊙	○
⊙	○



⊙	⊙	⊙	○	○	○	⊙	○		
⊙	⊙	⊙	○	○	○	⊙	○		
⊙	⊙	⊙	○	○	○	⊙	○		
⊙	⊙	⊙	○			⊙			
⊙	⊙	⊙	○			⊙			
						⊙			
⊙	⊙	⊙	○	○	○	⊙	○		

⊙	⊙	⊙	○			⊙			
⊙	⊙	⊙	○			⊙			

⊙	⊙	⊙	○			⊙			
⊙	⊙	⊙	○	○	○	⊙	○		



		Z			●	■	◆	▲	
DIXI 81000 Ø 40 - 100		2	368	  	✓		✓		
DIXI 80000 Ø 40 - 125		6 - 16	369	  	✓	□		□	
DIXI 11140		1	369		□				
DIXI 11180		2	369		□				
POLY 40010-2 Ø 8.00 - 22.10		4	370	 	□			□	
POLY 40010-3 Ø 8.00 - 22.10		4	370	 	□			□	
DIXI 25800		-	370		□	□	□	□	
DIXI 25810		-	370		□	□	□	□	
DIXI 20610		-	371		□	□	□	□	
DIXI 20770		-	371		□	□	□	□	
ARTDECO 26500 TR		-	372		✓	□	□	□	
ARTDECO 26500 FT		-	372		✓	□	□	□	

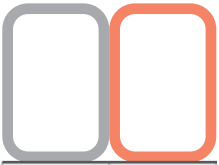

◎	○

◎	○
◎	○
◎	○
◎	○

◎	○
◎	○
◎	○
◎	○







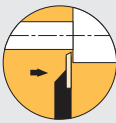

◎	◎	◎	○			◎			
◎	◎	◎	○						

◎	◎	◎	○	○	○	◎	○		
◎	◎	◎	○	○	○	◎	○		

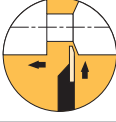
◎	◎	◎	○	○	○	◎	○		
◎	◎	◎	○	○	○	◎	○		
◎	◎	◎	○	○	○	◎	○		
◎	◎	◎	○	○	○	◎	○		

◎	◎	◎	○	○	○	◎	○		
◎	◎	◎	○	○	○	◎	○		
◎	◎	◎	○	○	○	◎	○		
◎	◎	◎	○	○	○	◎	○		

	Z			●	■	◆	▲	
ARTDECO 26500 AV 	-	372		✓	☐	☐	☐	
ARTDECO 26500 AR 	-	372		✓	☐	☐	☐	
DIXI 264X0 	-	371		☐	☐	☐	☐	
DIXI 1973 	-	377						
DIXI 1978 	-	377		✓	✓			



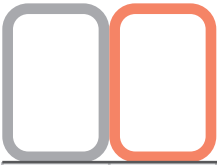

◎	○
◎	○
◎	○



◎	◎	◎	○	○	○	◎	○		
◎	◎	◎	○	○	○	◎	○		
◎	◎	◎	○	○	○	◎	○		



DIXI 72420

Z = 1-2



P. 380

$D_1 \geq \emptyset 6$

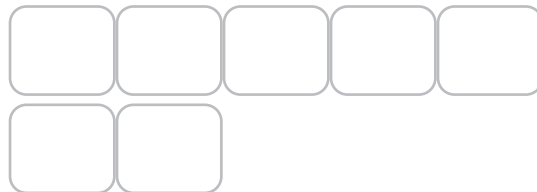
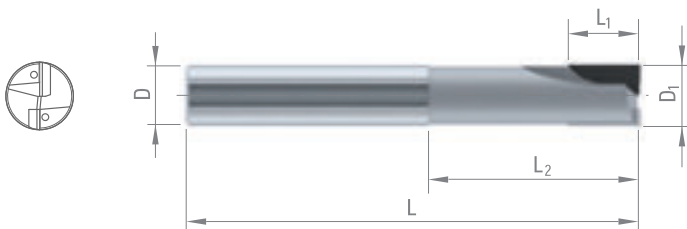

D_{1h10}	L_1	L_2	D_{h5}	L	Z		
1.00	2.0	-	6	42	1	979179	
1.50	3.0	-	6	42	1	977382	
2.00	3.0	6	6	42	1	66785	
2.00 >	3.0	20	6	75	1	970175	
3.00	4.0	6	6	42	1	67540	301958
3.00 >	4.0	6	6	42	2		305549
3.00 >	4.0	15	6	75	2	970176	
3.00 >	4.0	20	6	75	2	970177	
4.00	4.0	8	6	50	1	957593	
4.00 >	6.5	10	6	50	1	67541	301959
4.00 >	6.5	15	6	75	2	970178	
4.00 >	6.5	25	6	75	2	970179	
5.00	5.0	10	6	50	2	957595	
5.00 >	6.5	10	6	50	2	53153	
5.00 >	6.5	35	6	75	2	970166	301960
6.00	6.0	12	6	57	2	976391	301961
6.00 >	8.0	34	6	75	2	976392	
6.00 >	8.0	50	6	100	2	976393	
7.00	8.0	34	8	75	2	976394	301962
8.00	7.0	14	8	63	2	976395	301963
8.00 >	10.0	34	8	75	2	976396	
8.00 >	10.0	50	8	100	2	976397	
8.00 >	10.0	75	8	125	2	976398	
9.00	10.0	35	10	75	2	976399	
10.00	8.0	16	10	75	2	976410	301965
10.00 >	12.0	35	10	75	2	976411	
10.00 >	12.0	75	10	125	2	976412	
11.00	12.0	38	12	83	2	976413	
12.00	10.0	20	12	83	2	976414	301966
12.00 >	12.0	38	12	83	2	976415	
12.00 >	12.0	75	12	125	2	976416	
14.00	12.0	24	14	83	2	976417	
14.00 >	12.0	38	14	83	2	976418	
14.00 >	12.0	75	14	125	2	976419	
16.00	14.0	28	16	92	2	976420	
16.00 >	14.0	42	16	92	2	976421	
16.00 >	14.0	75	16	125	2	976422	
20.00	18.0	36	20	104	2	976423	
20.00 >	18.0	50	20	125	2	976424	

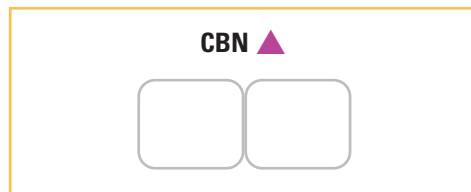

DIXI 70520 PCD

Z = 1-2

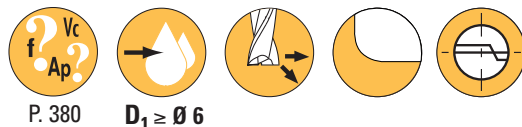

P. 380

$D_1 \geq \varnothing 6$

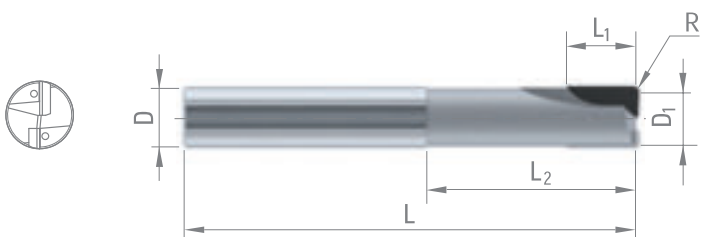

D_{1h10}	L_1	L_2	D_{h5}	L	R	Z	
1.00	2.0	-	6	42	0.1	1	984384
2.00	3.0	6	6	42	0.1	1	967923
2.00 >	3.0	6	6	42	0.2	1	973528
3.00	4.0	15	6	75	0.1	2	987438
3.00 >	4.0	15	6	75	0.3	2	305810
4.00	4.0	8	6	50	0.1	1	967925
4.00 >	6.5	10	6	50	0.5	2	971465
4.00 >	6.5	15	6	75	0.1	2	305811
4.00 >	6.5	15	6	75	0.5	2	302378
5.00	5.0	10	6	50	0.1	2	305812
5.00 >	5.0	10	6	50	0.5	2	975839
6.00	6.0	12	6	57	0.1	2	967926
6.00 >	6.0	12	6	57	0.5	2	968992
6.00 >	8.0	34	6	75	0.1	2	995208
6.00 >	8.0	34	6	75	0.5	2	974475
6.00 >	8.0	34	6	75	1.0	2	974476
8.00	7.0	14	8	63	0.1	2	967927
8.00 >	10.0	34	8	75	0.5	2	974477
8.00 >	10.0	34	8	75	1.0	2	974478
10.00	12.0	35	10	75	0.1	2	953153
10.00 >	12.0	35	10	75	0.5	2	974479
10.00 >	12.0	35	10	75	1.0	2	974480
10.00 >	12.0	75	10	125	0.5	2	974482
10.00 >	12.0	75	10	125	1.0	2	974481
12.00	10.0	20	12	83	0.1	2	984083
12.00 >	12.0	38	12	83	0.5	2	974483
12.00 >	12.0	38	12	83	1.0	2	974484
12.00 >	12.0	75	12	125	0.5	2	974485
12.00 >	12.0	75	12	125	1.0	2	974486
14.00	12.0	24	14	83	0.1	2	305814
14.00 >	12.0	24	14	83	0.5	2	305816
14.00 >	12.0	24	14	83	1.0	2	305817
16.00	14.0	28	16	92	0.1	2	993052
16.00 >	14.0	42	16	92	0.5	2	305818
16.00 >	14.0	42	16	92	1.0	2	305139
20.00	18.0	36	20	104	0.1	2	987718
20.00 >	18.0	36	20	104	0.5	2	305919
20.00 >	18.0	36	20	104	1.0	2	305820

CVD ■

CBN ▲

--	--



DIXI 70600 PCD



Z = 1

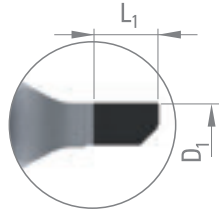
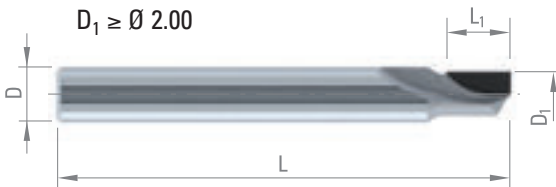
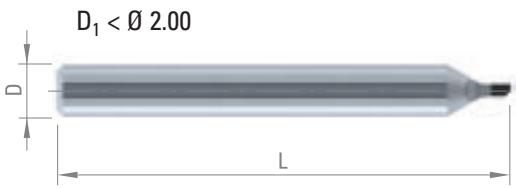

P. 380



$D_{1\ h10}$	L_1	D_{h5}	L	
1.00	2.0	6	35	302387
2.00	3.0	6	35	302388
3.00	4.0	6	42	302389
4.00	6.5	6	42	302390
5.00	6.5	6	50	302391
6.00	8.0	6	50	302393

DIXI 70600 DIA



Z = 1

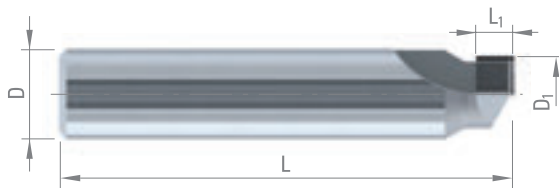

P. 380



--	--	--

D_1	L_1	D_{h5}	L	DIA
3.00	2.5	6	30	302394
4.00	2.5	6	30	302395
5.00	2.5	6	30	302396
6.00	2.5	6	30	302397

DIXI 72310 DIA

Z = 1

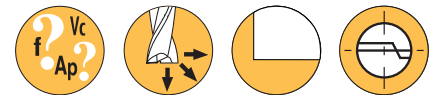

P. 380



D ₁	L ₁	D _{h5}	L	DIA
0.30	0.6	3	30	953423
0.40	0.8	3	30	953424
0.50	1.0	3	30	953425
0.60	1.2	3	30	953426
0.70	1.4	3	30	953427
0.80	1.6	3	30	953428
0.90	1.8	3	30	953429
1.00	2.5	3	30	953430
1.10	2.5	3	30	953431
1.20	2.5	3	30	953432
1.30	2.5	3	30	953433
1.40	2.5	3	30	953434
1.50	2.5	3	30	953435
1.60	2.5	3	30	953436
1.70	2.5	3	30	953437
1.80	2.5	3	30	953438
1.90	2.5	3	30	953439
2.00	2.5	6	30	953440



DIXI 72421 DIA



Z = 1



P. 380

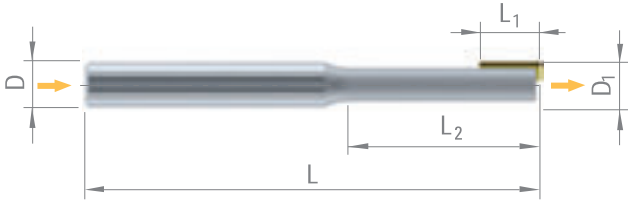

D_1	L_1	L_2	D_{h5}	L	DIA
6.00	4	25	6	57	970120
6.00	6	25	6	57	970122
6.00	8	25	6	57	974360
8.00	4	25	8	63	970126
8.00	6	25	8	63	970128
8.00	8	25	8	63	970129
10.00	4	25	10	75	974317
10.00	6	25	10	75	974318
10.00	8	25	10	75	974319
12.00	4	25	12	83	974321
12.00	6	25	12	83	974322
12.00	8	25	12	83	974323





Z = 1-2



P. 380

> Ø 6

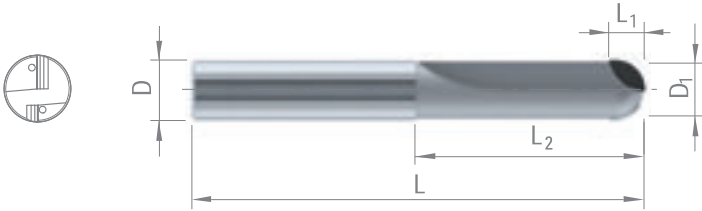

$D_{1\ h10}$	L_1	L_2	D	L	Z	
2.00	2.0	6.0	6	42	1	953442
2.00	2.0	25.0	6	75	1	970874
3.00	2.5	6.0	6	42	1	953443
3.00	2.5	25.0	6	75	1	970875
3.00	2.5	25.0	6	75	2	970876
4.00	3.0	8.0	6	50	1	959468
4.00	3.0	10.0	6	50	1	953444
4.00	3.0	10.0	6	50	2	970877
4.00	3.0	25.0	6	75	2	970878
4.00	3.0	35.0	6	75	2	981585
5.00	4.0	10.0	6	50	2	953445
5.00	4.0	25.0	6	75	2	970883
6.00	4.0	12.0	6	57	2	976433
6.00	4.0	34.0	6	75	2	976434
6.00	4.0	50.0	6	100	2	976435
8.00	5.0	14.0	8	63	2	976436
8.00	5.0	34.0	8	75	2	976437
8.00	5.0	75.0	8	125	2	976438
10.00	6.0	16.0	10	72	2	976439
10.00	6.0	35.0	10	75	2	976440
10.00	6.0	75.0	10	125	2	976441
12.00	7.0	20.0	12	83	2	976442
12.00	7.0	38.0	12	83	2	976443
12.00	7.0	75.0	12	125	2	976444
14.00	8.0	24.0	14	83	2	305821
16.00	9.0	28.0	16	92	2	300800
20.00	11.0	36.0	20	104	2	305822

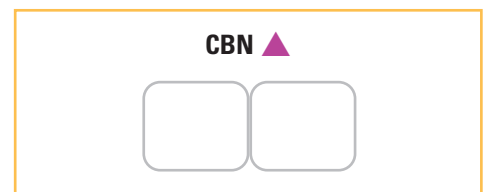
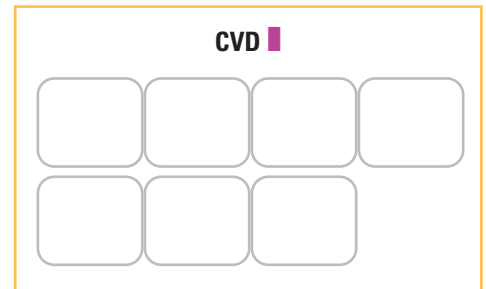

DIXI 76230 DIA



Z = 1

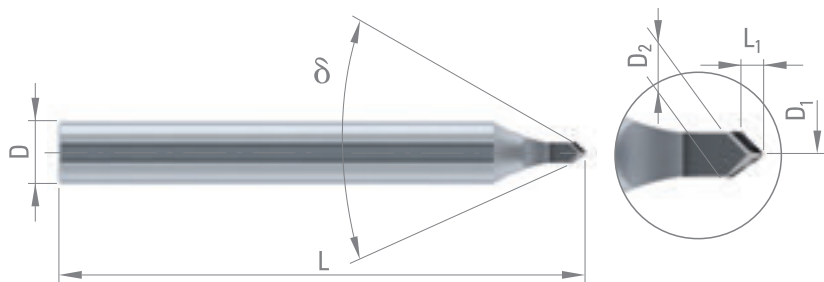

D ₁	L ₁	D ₂	δ	D _{h5}	L	DIA
* 0.10	1.40	3	60°	6	50	302596
* 0.10	0.80	3	90°	6	50	302595
* 0.30	2.80	2	30°	6	50	978382
* 0.30	1.30	3	60°	6	50	978381
* 0.30	0.70	3	90°	6	50	977871

DIXI 76230



Z = 1

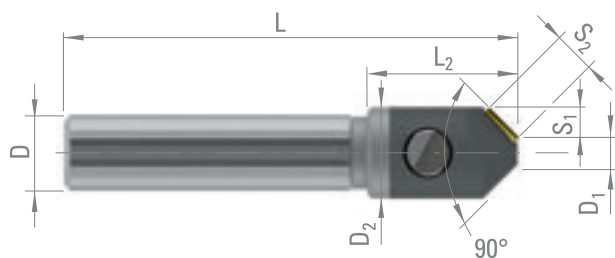

D ₁	D ₂	L ₂	S ₁	S ₂	D _{h5}	L	DIA
4	10	-	3	4.10	10	60	◆
4	12	20	4	5.50	10	60	◆
4	14	20	5	7.00	10	60	◆
4	16	20	6	8.50	10	60	◆



DIXI 70170 DIA - 70180 DIA

Z = 1

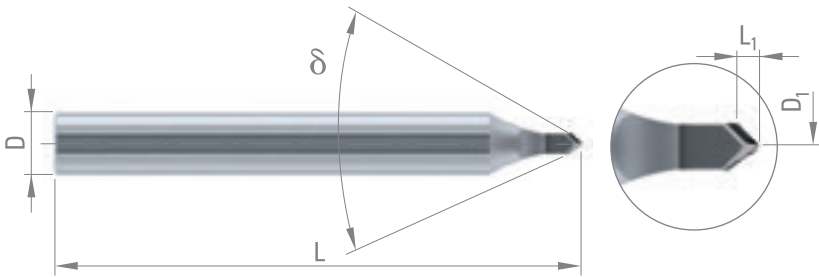

D ₁	L ₁	δ	D _{h5}	L	DIA
0.05	1.40	60°	6	50	302597
0.10	1.40	60°	6	50	302598
0.05	0.80	90°	6	50	302599
0.10	0.80	90°	6	50	302600

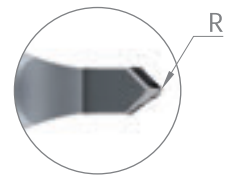

DIXI 70170 PCD - 70180 PCD

Z = 1

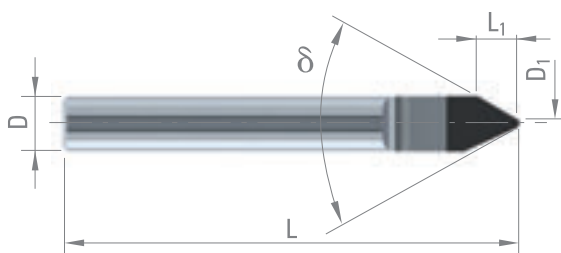

D ₁	L ₁	δ	D _{h5}	L	DIA
0.10	5	60°	6	50	303081
0.20	5	60°	6	50	303082
0.10	3	90°	6	50	303083
0.20	3	90°	6	50	303084





DIXI 15150

- Z = _____
- D = _____
- D₁ = _____
- D₂ = _____
- L = _____
- L₁ = _____
- L₂ = _____
- R = _____

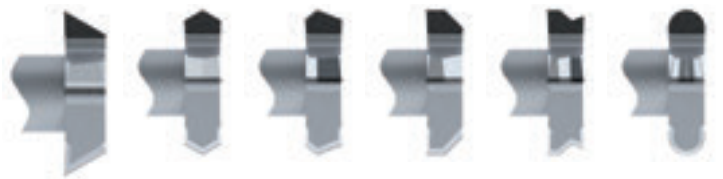
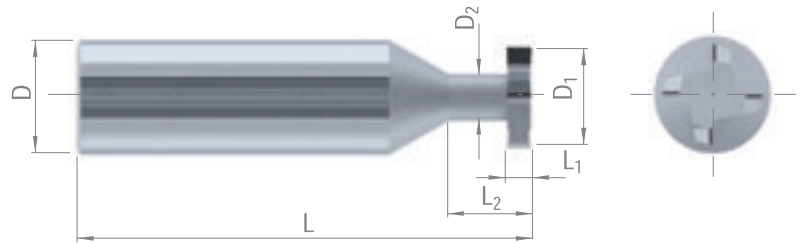

DIXI 16560

- D₁ = _____
- D₂ = _____
- L₁ = _____
- R = _____
- A = _____
- B = _____

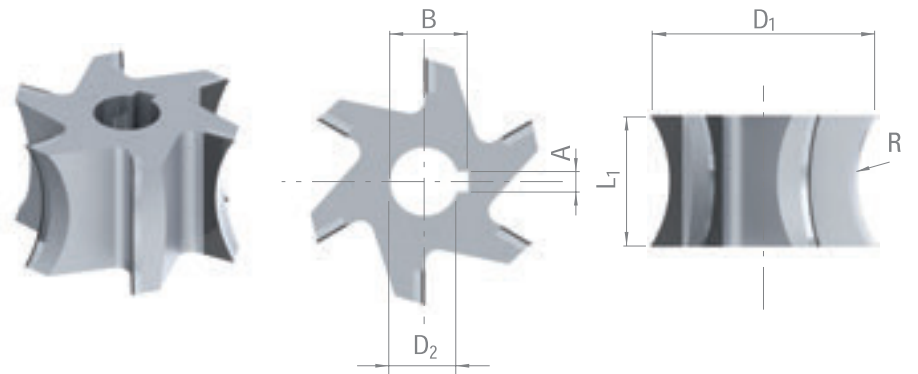

Ref. A

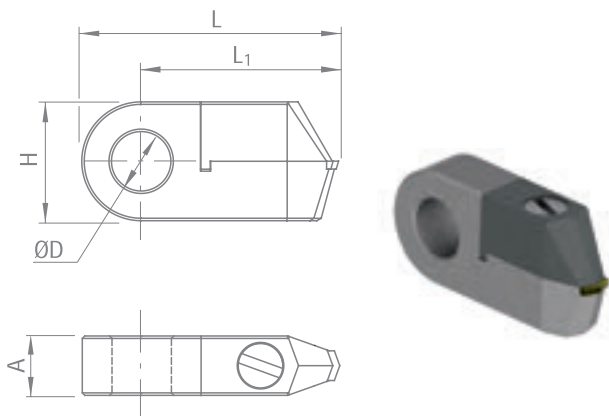

Ref. B

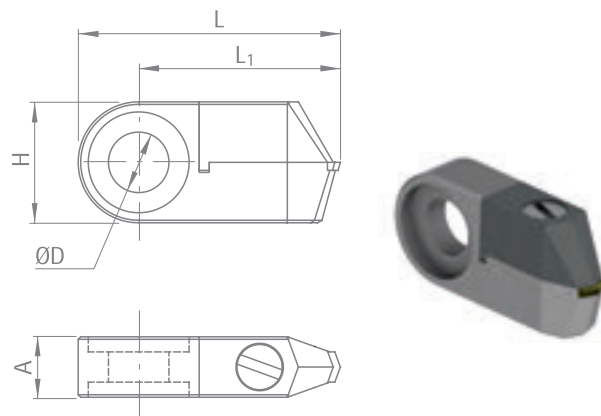

Ref. C

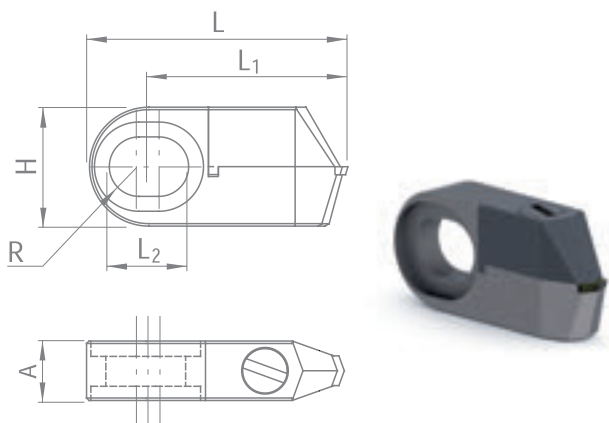

Ref. D

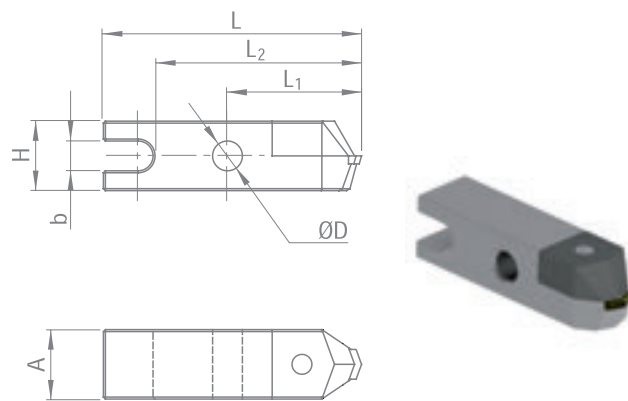

Ref. E

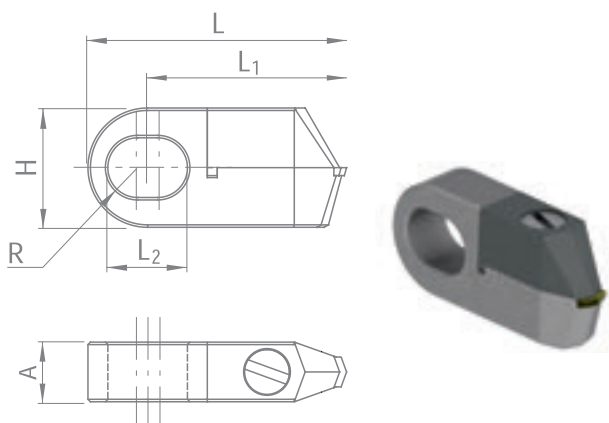

DIXI 81000



P. 382



D_1	D	L	Art.
60	22	50	996583
85	22	48	996583
100	27	55	964272

D_1	D	L	Art.
40	16	55	970446
50	16	45	971872
60	22	40	962823

D_1	D	L	Art.
40	12	55	996583

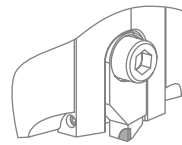
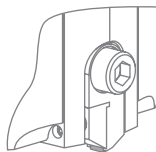
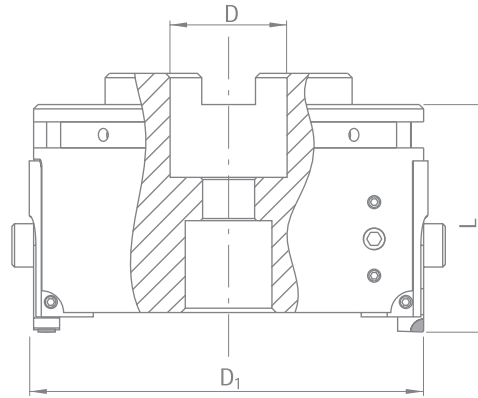

968117
969556
968526
969557

968117

DIXI 20370

Ref. 1



Ref. 2



Ref. 3



Ref. 4



968179
968181
974193
968178



DIXI 80000

Z = 6-16



P. 382

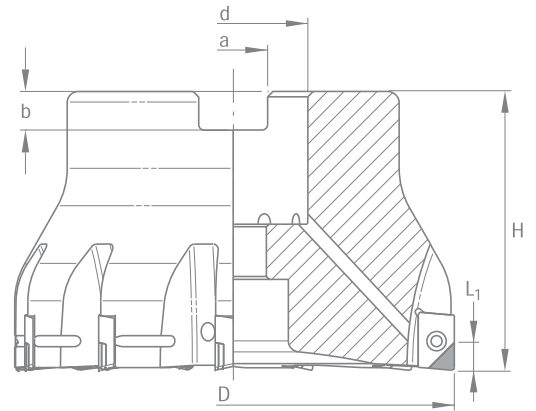

40.00	3.0	40	8.4	6.6	16	6	0.20
50.00	3.0	40	10.4	7.2	22	7	0.35
63.00	3.0	40	10.4	7.2	22	8	0.60
80.00	3.0	50	12.4	7.2	27	11	1.20
100.00	3.0	50	14.4	8.2	32	13	2.00
125.00	3.0	50	16.4	9.0	32	16	2.20

DIXI 11140 - 11180

DIXI 11140 A - PCD

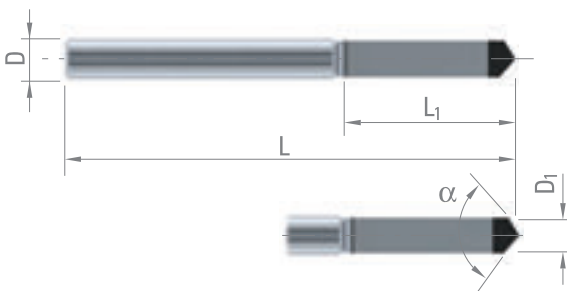

DIXI 11140 B - PCD

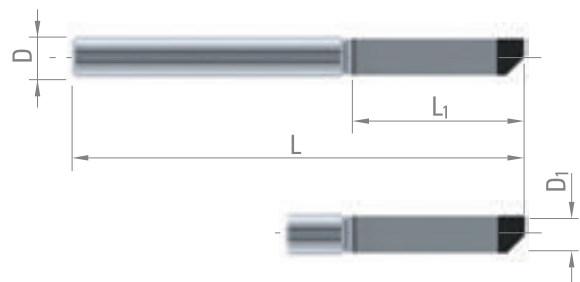

DIXI 11180 - PCD

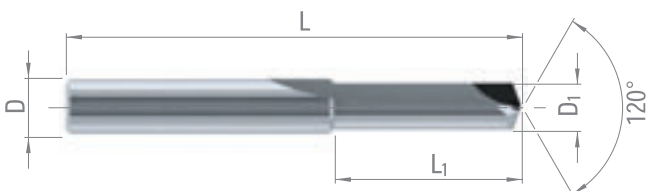

POLY 40010



POLY 40010-2

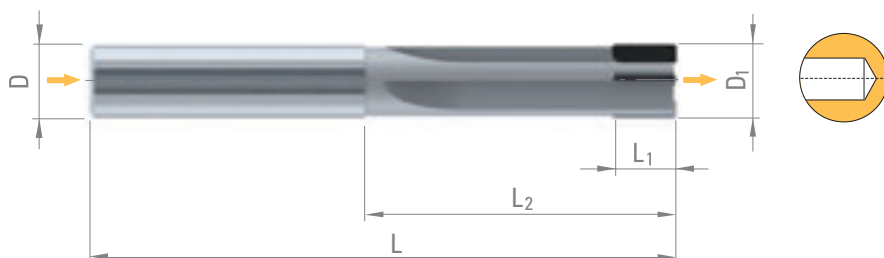

POLY 40010-3



D_1	L_1	L_2	D_{h5}	L	Z	CBN
8.000 - 9.100	7	34	8	64	4	● ▲
9.102 - 10.100	7	44	10	80	4	● ▲
10.101 - 11.100	7	44	10	80	4	● ▲
11.101 - 12.300	7	63	12	108	4	● ▲
12.300 - 13.100	7	63	12	108	4	● ▲
13.101 - 14.500	7	58	16	108	4	● ▲
14.501 - 16.100	7	58	16	108	4	● ▲
16.101 - 18.100	7	58	16	108	4	● ▲
18.101 - 20.500	7	58	20	108	4	● ▲
20.501 - 22.100	7	58	20	108	4	● ▲

DIXI 25800 - 25810

DIXI 25800

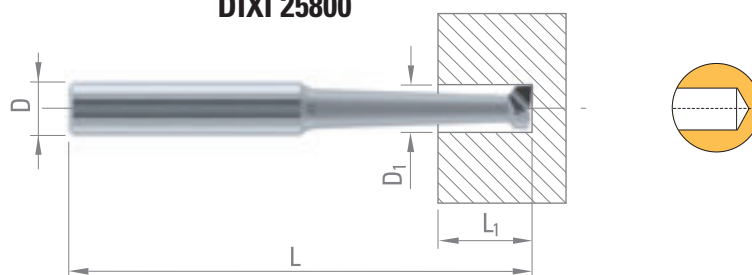

DIXI 25810

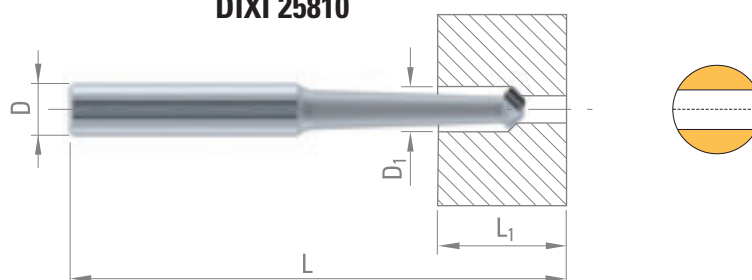

DIXI 20160-20770



P. 384

DIXI 20610

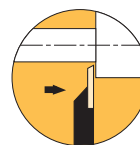

DIXI 20770

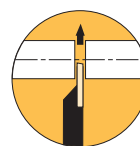

DIXI 264X0

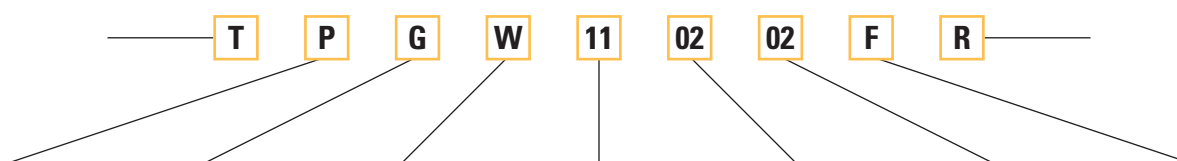
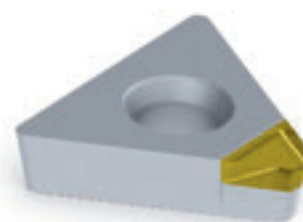



ARTDECO 26500 TR

R	A	L ₁		
TR06R-0.8	0.8	3.0	976284	303109
TR06R-1.0	1.0	4.0	976286	303111
TR06R-1.2	1.2	5.0	976288	303113
TR06R-1.5	1.5	5.0	976290	303115
TR06R-1.8	1.8	6.0	976292	303117
TR06R-2.0	2.0	6.0	976294	303119

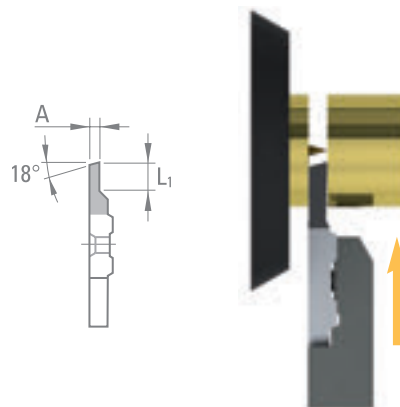

ARTDECO 26500 FT

R	A	L ₁		
FT06R-2.0	2.0	4.0	976278	303103

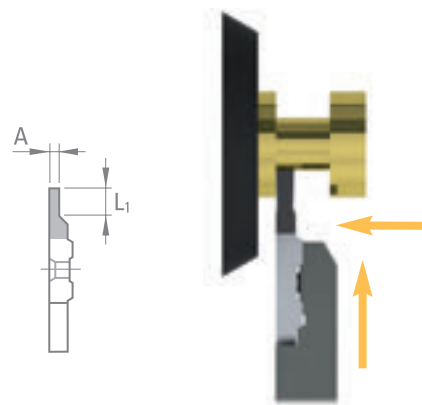

ARTDECO 26500 AV

R	A	L ₁		
AV06R-1.5	1.5	5.0	976280	303105

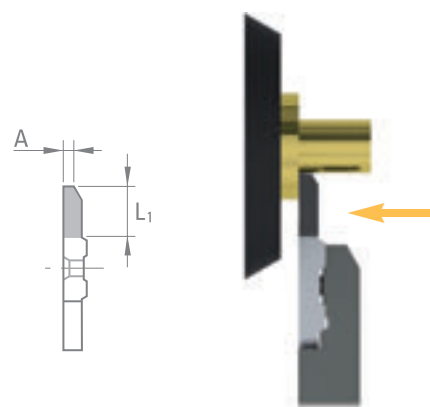

ARTDECO 26500 AR

R	A	L ₁		
AR06R-1.0	1.0	5.0	976282	303107

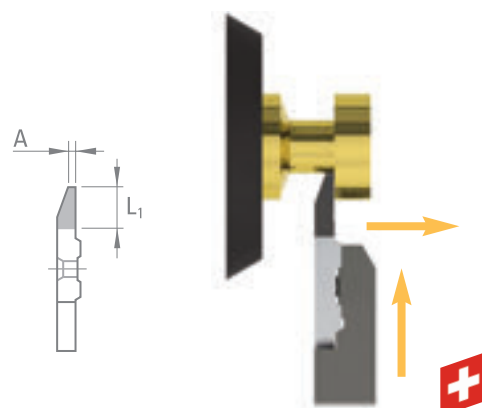



ARTDECO 26500 TR

L	A	L ₁		
TR06L-0.8	0.8	3.0	976285	303110
TR06L-1.0	1.0	4.0	976287	303112
TR06L-1.2	1.2	5.0	976289	303114
TR06L-1.5	1.5	5.0	976291	303116
TR06L-1.8	1.8	6.0	976293	303118
TR06L-2.0	2.0	6.0	976295	303120

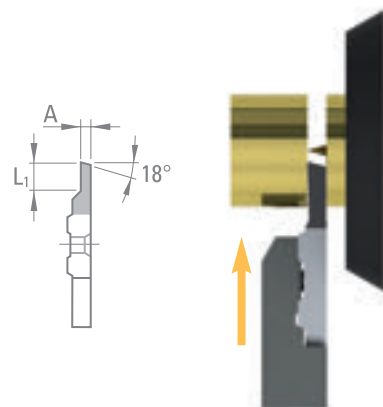

ARTDECO 26500 FT

L	A	L ₁		
FT06L-2.0	2.0	4.0	976279	303104

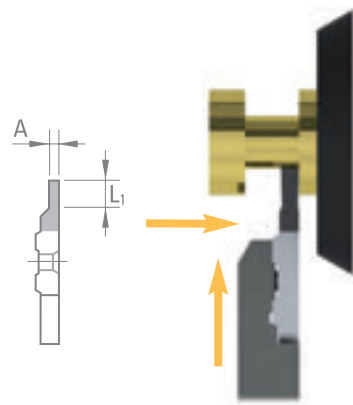

ARTDECO 26500 AV

L	A	L ₁		
AV06L-1.5	1.5	5.0	976281	303106

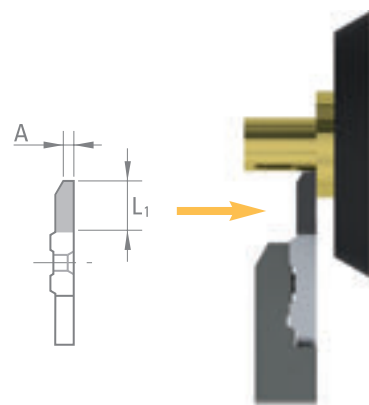

ARTDECO 26500 AR

L	A	L ₁		
AR06L-1.0	1.0	5.0	976283	303108

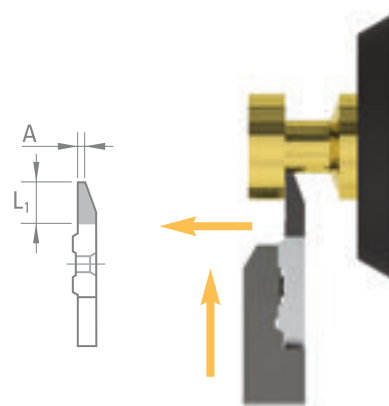

ARTDECO 2753

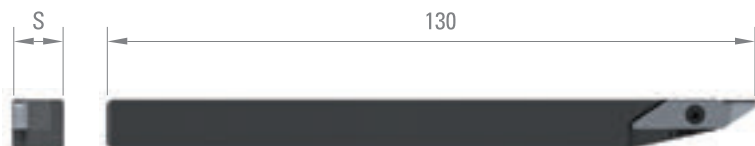

0606R-130	6	06	64940
0706R-130	7	06	64942
0806R-130	8	06	64944
1006R-130	10	06	64946
1206R-130	12	06	64948
1606R-130	16	06	64950

0606L-130	6	06	64941
0706L-130	7	06	64943
0806L-130	8	06	64945
1006L-130	10	06	64947
1206L-130	12	06	64949
1606L-130	16	06	64959



Torx 8 Art. 65785







DIXI 1973



Ref.	D	Art.
DIXI 1973.0823	8	19459
DIXI 1973.1023	10	18512
DIXI 1973.1223	12	19979

Ref.	D	Art.
DIXI 1973.1013	10	23707

DIXI 1973.0023	CM0	46.5	18737
DIXI 1973.0123	CM1	59.5	18514

DIXI 1973.0013	CM0	23850
DIXI 1973.0113	CM1	23727

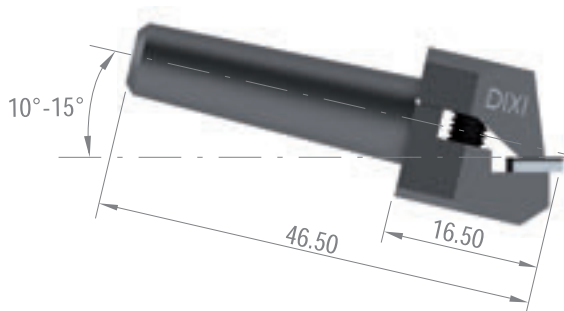
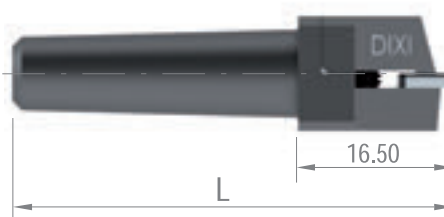
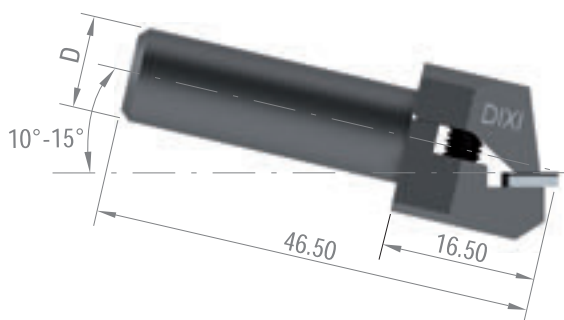
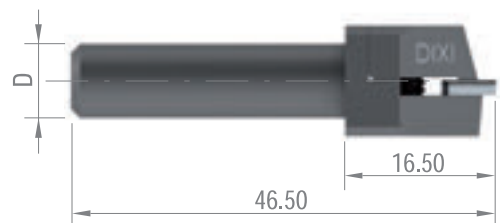

DIXI 1978



DIXI 1978.360°

23829

DIXI 1978.23

18814

DIXI 1973



Ref.	D	Art.
DIXI 1973.1025	10	24550

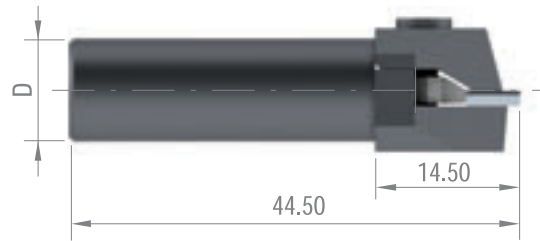

Ref.	Art.
DIXI 1973.0925-1	24549

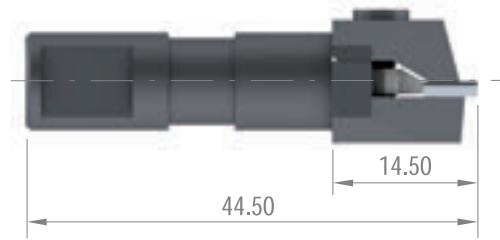

DIXI 1973.0125	CM1	36.5	26549
DIXI 1973.0125	CM1	58.5	24551

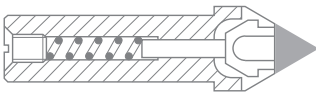

DIXI 1978



Ref.	PCD	CVD
DIXI 1978.2500	24623	973739

Ref.	R	PCD	CVD
DIXI 1978.2512	0.125	24624	973736
DIXI 1978.2520	0.200	24625	973732
DIXI 1978.2525	0.250	24626	973737
DIXI 1978.2550	0.500	24627	973738





I 1	J 1	K 1	L 1	M 1
I 2	J 2	K 2	L 2	M 2
I 3	J 3	K 3	L 3	M 3
I 4	J 4	K 4	L 4	M 4
I 5	J 5	K 5	L 5	M 5
I 6	J 6	K 6	L 6	M 6
I 7	J 7	K 7	L 7	M 7
I 8	J 8	K 8	L 8	M 8
I 9	J 9	K 9	L 9	M 9
I 10	J 10	K 10	L 10	M 10
•	•	•	•	•
•	•	•	•	•
•	•	•	•	•

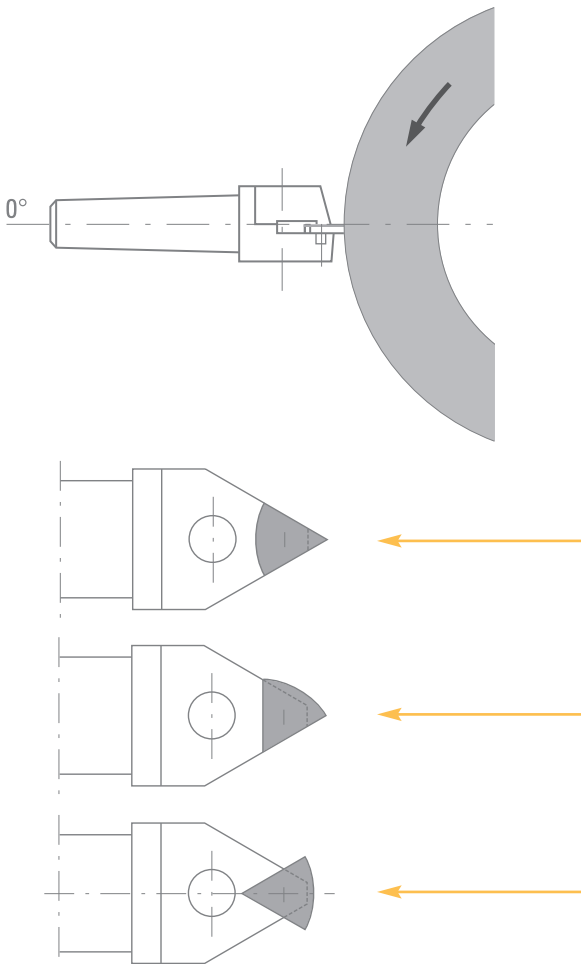

DIXI 72310 DIA

N		400	800	
N		300	700	
N		500	2000	
N		400	1800	
N		400	1500	
N		500	1500	
N		200	750	

DIXI 70600 - 70320 - 70520 - 72420 - 72421

H					160	280
K					160	280
N		200	1000	400	1200	400 800
N		100	1500	200	1700	300 700
N		700	3000	400	1200	500 2000
N		300	3500	400	1200	400 1800
N		100	3000	200	900	400 1200
N		200	1000	400	1200	
N		200	1000	400	1200	
N		500	2000	400	1200	500 1500
N		1000	3000	400	1200	
N		300	1000	400	1200	200 750



$$n \text{ [tr/min]} = \frac{V_c \text{ [m/min]} \times 1000}{\pi \times D_1 \text{ [mm]}}$$

$$V_f \text{ [mm/min]} = n \text{ [tr/min]} \times f_z \text{ [mm]} \times z$$

f_z [mm]

0.0005 - 0.005	0.005 - 0.03	
0.0005 - 0.005	0.005 - 0.03	
0.0005 - 0.005	0.005 - 0.03	
0.0005 - 0.005	0.005 - 0.03	
0.0005 - 0.005	0.005 - 0.03	
0.0005 - 0.005	0.005 - 0.03	
0.0005 - 0.005	0.005 - 0.03	

0.10 - 0.15	≤ 0.5 x D	≤ 0.5 x D	0.10 - 0.30	0.10 - 0.30	max. = 0.05
0.10 - 0.20	≤ 0.6 x D	≤ 0.6 x D	0.10 - 0.30	0.10 - 0.30	
0.05 - 0.25	≤ 1 x D	≤ 1 x D	0.10 - 0.30	0.10 - 0.30	
0.05 - 0.20	≤ 0.6 x D	≤ 0.6 x D	0.10 - 0.30	0.10 - 0.30	
0.05 - 0.25	≤ 1 x D	≤ 1 x D	0.10 - 0.30	0.10 - 0.30	
0.05 - 0.20	≤ 1 x D	≤ 1 x D	0.10 - 0.30	0.10 - 0.40	
0.05 - 0.20	≤ 1 x D	≤ 1 x D	0.10 - 0.30	0.10 - 0.30	
0.05 - 0.20	≤ 1 x D	≤ 1 x D	0.10 - 0.30	0.10 - 0.30	
0.025 - 0.125	≤ 1 x D	≤ 1 x D	0.10 - 0.30	0.10 - 0.30	
0.05 - 0.30	≤ 1 x D	≤ 1 x D	0.10 - 0.30	0.10 - 0.30	
0.05 - 0.30	≤ 1 x D	≤ 1 x D	0.10 - 0.30	0.10 - 0.30	
0.05 - 0.25	≤ 0.6 x D	≤ 0.6 x D	0.10 - 0.30	0.10 - 0.30	



DIXI 80000

H			350	700	
K			500	1600	
N		< 3000	< 3000		
N		< 3000	< 3000		
N		< 7000	< 7000		
N		< 6000	< 6000		
N		< 5000	< 5000		

DIXI 81000

N		400	800		
N		300	700		
N		500	2000		
N		400	1800		
N		400	1200		
N		500	1500		
N		200	750		



$$n \text{ [tr/min]} = \frac{Vc \text{ [m/min]} \times 1000}{\pi \times D_1 \text{ [mm]}}$$

$$Vf \text{ [mm/min]} = n \text{ [tr/min]} \times fz \text{ [mm]} \times z$$

ap [mm]	fz [mm]	
0.20 - 1.00	0.04 - 0.12	
0.20 - 1.50	0.08 - 0.15	
0.10 - 3.50	0.05 - 0.25	
0.10 - 3.50	0.05 - 0.25	
0.10 - 3.50	0.05 - 0.25	
0.10 - 3.50	0.05 - 0.25	
0.10 - 3.50	0.05 - 0.25	

ap [mm]	fz [mm]	
< 2	0.02 - 0.2	
< 2	0.02 - 0.2	
< 2	0.02 - 0.2	
< 2	0.02 - 0.2	
< 2	0.02 - 0.2	
< 2	0.02 - 0.2	
< 2	0.02 - 0.2	



H					100	200
K					200	600
N		300	1000	300	1000	300
N		250	800	250	800	250
N		300	1000	300	1000	300
N		300	1000	300	1000	300
N		250	800	250	800	250
N		80	1500	80	1500	
N		100	800	100	800	
N		100	600	100	600	100
N		100	600	100	600	
N		300	1000	300	1000	300



$$n \text{ [tr/min]} = \frac{Vc \text{ [m/min]} \times 1000}{\pi \times D_1 \text{ [mm]}}$$

$$Vf \text{ [mm/min]} = n \text{ [tr/min]} \times fz \text{ [mm]} \times z$$

< 3	0.05 - 0.20			
< 3	0.05 - 0.70			
< 10	0.05 - 0.50	< 0.05	0.05 - 0.50	
< 6	0.05 - 0.50	< 0.05	0.05 - 0.50	
< 10	0.05 - 0.50	< 0.05	0.05 - 0.50	
< 10	0.05 - 0.50	< 0.05	0.05 - 0.50	
< 6	0.05 - 0.50	< 0.05	0.05 - 0.50	
< 10	0.05 - 0.50			
< 5	0.05 - 0.20			
< 10	0.10 - 0.60	< 0.05	0.10 - 0.60	
< 3	0.05 - 0.60			
< 6	0.05 - 0.50	< 0.05	0.05 - 0.50	

